

# PREPARATORY PROBLEMS



**54<sup>th</sup> IChO 2022**  
International Chemistry Olympiad



TIANJIN, CHINA

## Table of contents

Preface .....	3
Contributing authors.....	4
Fields of advanced difficulty .....	6
Physical constants and equations.....	7
Periodic table of the Elements.....	9
Problem 1. The Past and Present of Bronzeware .....	13
Problem 2. The Chemical Element in Mysterious Elixir.....	15
Problem 3. Cyanotype, Prussian blue and Related Compounds.....	17
Problem 4. Painted Sculpture "Clay Figure Zhang" .....	20
Problem 5 Chinese Cloisonné .....	21
Problem 6. Titanium is awesome .....	23
Problem 7. Kaolinite and Sodalite.....	25
Problem 8. Mars Chemistry.....	27
Problem 9. Greenhouse Gas and Carbon Neutrality .....	28
Problem 10. Packing of binary crystals .....	31
Problem 11. Determination of Calcium Ions by Titration with Ethylene Bis(oxyethylenenitrilo) Tetraacetic Acid (EGTA).....	32
Problem 12. Fast determination of Vitamin C by gold colloids.....	33
Problem 13. Allenes.....	34
Problem 14. Cyclopropanes.....	39
Problem 15. Lewis base catalysis.....	42
Problem 16. Isosorbitol .....	47
Problem 17. Total Synthesis of Hopeanol.....	48
Problem 18. Total Synthesis of Lithospermic acid.....	51
Problem 19. Reaction of peptides .....	53
Problem 20. Total Synthesis of Hapalindole-Type Natural Products.....	56
Problem 21. Total Synthesis of Schindilactone A.....	59
Problem 22. Recyclable Plastic—Turning Waste into Treasure .....	61
Problem 23. The combustion of water gas.....	64
Problem 24. The thermodynamics of decomposition reactions.....	65

Problem 25. The condensation of 1-butanol vapor .....	65
Problem 26. Chemical kinetics .....	66
Problem 27: Electrochemistry.....	67
Problem 28. $\pi$ -conjugated systems .....	67
Practical Tasks.....	69
Safety.....	70
P1. Extraction of Berberine and Its Structural Characterization .....	71
P2. Synthesis of (2,4-Dichlorophenoxy)acetic Acid and Evaluation of Product Purity .....	73
P3. Enzymatic Protein Digestion.....	76
P4. Synthesis of the Thermochromic Spin-crossover Materials.....	81
P5. The Extraction of Indigo from Radix Isatidis and its Synthesis for Application in Tie-dyeing ...	83
P6. Synthesis of Carbon Dots from Kitchen Wastes .....	87
P7. Synthesis and Purity Analysis of N-acetylphenylalanine in Aqueous Phase .....	90
P8. Reaction Types and Chemical Logic (Virtual Experiment) .....	92
P9. Properties and Identification of Heavy Metal Ions (Virtual Experiment).....	94

## Preface

We are delighted to provide the Preparatory Problems for the 54<sup>th</sup> International Chemistry Olympiad, which will be held in 2022 in Tianjin, China. As indicated in the Regulations, the purpose of distributing a set of preparatory tasks to all participating countries is to help give students a good idea of the type and difficulty of the competition tasks, as well as safety aspects. (Please see IChO Regulations § 10) Additionally, the content of problems is intended to cover a wide range of challenging topics across history and different cultures, and was chosen with care and in the hope of being both educational and entertainment. We hope all students and mentors will enjoy solving these problems as they prepare for the Olympiad. The problems are containing 6 topics of advanced difficulty for the Theoretical part and 3 topics of advanced difficulty for the Practical part. The problems can be solved by applying fundamental principles of chemistry covered at secondary (high) school level. These advanced topics are listed explicitly under ‘Topics of Advanced Difficulty’ and their applications are illustrated in the tasks. Participants are expected to be familiar with these advanced topics, as they are good indicators for the final competition.

The problems listed this booklet include 28 theoretical and 9 practical tasks. The solutions will be sent to the Head Mentor of each country by e-mail by February 2022 and, published by June, 2022 on our IChO 2022 website. All comments, suggestions, corrections, and queries related to these problems are welcome; please contact [icho2022@nankai.edu.cn](mailto:icho2022@nankai.edu.cn).

The International Chemistry Olympiad is a great opportunity for young people from all over the world to deepen their understanding of the wonders of chemistry, and inspire each other. At the same time, it is a wonderful opportunity to make friends around the world, and enjoy the history and culture of the host country.

It’s been two years since the start of the COVID-19 pandemic, and the situation is still not clear, but we do hope that we can meet you in Tianjin, China in the summer of 2022.

## Acknowledgements

We would like to express our deepest gratitude to all the authors for their great efforts in creating both preparatory and competition problems. We would also like to thank the members of the International Steering Committee for their valuable comments and suggestions.

Scientific Committee of IChO 2022

## Contributing authors

Gong CHEN	<i>(Nankai University)</i>
Liu-Ping CHEN	<i>(Sun Yat-Sen University)</i>
Fang-Yi CHENG	<i>(Nankai University)</i>
Peng CHENG	<i>(Nankai University)</i>
Lian-Yun DUAN	<i>(Peking University)</i>
Jin-Long GONG	<i>(Tianjin University)</i>
Dong-Sheng GUO	<i>(Nankai University)</i>
Jie HAN	<i>(Nankai University)</i>
Gang He	<i>(Nankai University)</i>
Zheng-Jie HE	<i>(Nankai University)</i>
Wan-Quan JIANG	<i>(University of Science and Technology of China)</i>
Quan LAN	<i>(University of Science and Technology of China)</i>
Ling-Ling LI	<i>(University of Science and Technology of China)</i>
Shu LI	<i>(Nankai University)</i>
Wan LI	<i>(University of Science and Technology of China)</i>
Yi-Jun LI	<i>(Nankai University)</i>
Yue LI	<i>(Nankai University)</i>
Guang-Xin LIANG	<i>(Shanghai Tech University)</i>
Ying-Jie LIN	<i>(Jilin University)</i>
Ding-Bin LIU	<i>(Nankai University)</i>
Yang LIU	<i>(Nankai University)</i>
Jian-Gong MA	<i>(Nankai University)</i>
Mei-Li PANG	<i>(Nankai University)</i>
Xiao-Hang QIU	<i>(Nankai University)</i>
Qi-Sheng SONG	<i>(Shandong University)</i>
Hong-Wei SUN	<i>(Nankai University)</i>
Ping-Ping TANG	<i>(Nankai University)</i>
Bai-Quan WANG	<i>(Nankai University)</i>
Yan-Guang WANG	<i>(Zhejiang University)</i>
Ying-Xia WANG	<i>(Peking University)</i>
Hua-Ping XU	<i>(Tsinghua University)</i>
Guang-Ming YANG	<i>(Nankai University)</i>
Qi-Zhi YAO	<i>(University of Science and Technology of China)</i>
Zheng-Gen ZHA	<i>(University of Science and Technology of China)</i>
Ming-Tao ZHANG	<i>(Nankai University)</i>
Xin-Xing ZHANG	<i>(Nankai University)</i>
Zhen-Jie ZHANG	<i>(Nankai University)</i>
Qi-Lin ZHOU	<i>(Nankai University)</i>
Ping-Ping ZHU	<i>(University of Science and Technology of China)</i>
Ya-Xian ZHU	<i>(Xiamen University)</i>

Edited by Dong-Sheng GUO & Hong-Wei SUN (*Nankai University*)

The Chair of Scientific Committee

Qi-Lin ZHOU (*Nankai University*)

The Director of Inorganic Chemistry Group

Xiao-Hang QIU (*Nankai University*)

The Director of Organic Chemistry Group

Ping-Ping TANG (*Nankai University*)

The Director of Physical Chemistry Group

Hong-Wei SUN (*Nankai University*)

The Director of Analytical Chemistry Group

Yi-Jun LI (*Nankai University*)

The Director of Practical Task Group

Yi-Jun LI (*Nankai University*)

## Fields of advanced difficulty

### Theoretical

1. Solid state structure, unit cell
2. Coordination chemistry: crystal field theory
3. Relation between equilibrium constants and standard reaction Gibbs free energy, relation between thermodynamic and electrochemical data
4. Stereochemistry including: conformation of molecules, symmetry, axial chirality, facial chirality, helical chirality, stereospecific reactions, stereoselectivity governed by steric hindrance, neighboring group effects and stereoelectronic effects
5.  $^1\text{H}$  NMR spectroscopy: chemical shifts, integrals, couplings and multiplicity
6. Reaction and reaction species including: pericyclic reactions, ylides, carbenes

### Practical

1. Suction filtration.
2. Use of a Soxhlet extractor.
3. Use of TLC for product identification.

### Notes

Students are not expected to cover the following advanced topics and skills:

#### Theoretical

Magnetic moment ( $\mu$ ) of complexes, Arrow-pushing mechanisms, Oxidative indole-enolate coupling, Burgess reagent, Dess-Martin periodinane oxidation, Pinnick oxidation, Meerwein-Ponndorf-Verley reduction, Swern oxidation

#### Practical

Use of a spectrometer, use of a rotary evaporator, handling of moisture-sensitive compounds (using syringes and balloons).

## Physical constants and equations

Avogadro Constant:	$N_A = 6.022 \times 10^{23} \text{ mol}^{-1}$
Universal gas constant:	$R = 8.314 \text{ J mol}^{-1} \text{ K}^{-1}$
Standard pressure:	$p^\ominus = 1 \text{ bar} = 10^5 \text{ Pa}$
Standard atmospheric pressure:	$P_{\text{atm}} = 1 \text{ atm} = 1.013 \text{ bar} = 1.013 \times 10^5 \text{ Pa}$
Zero of the Celsius scale:	273.15 K
Faraday constant:	$F = 9.6485 \times 10^4 \text{ C mol}^{-1}$
Planck's constant:	$h = 6.626 \times 10^{-34} \text{ J s}$
Mass of electron:	$m_e = 9.109 \times 10^{-31} \text{ kg}$
Speed of light:	$c = 2.998 \times 10^8 \text{ m s}^{-1}$
Energy of a photon:	$E = hc/\lambda$
Ideal gas equation:	$pV = nRT$
The first law of thermodynamics:	$\Delta U = q + w$
Enthalpy $H$ :	$H = U + PV$
Entropy $S$ :	$S = k_B \ln W$
The change of entropy:	$\Delta S = q_{\text{rev}}/T$
Gibbs free energy:	$G = H - TS$
	$\Delta G^\ominus = -RT \ln K^\ominus$
	$\Delta G^\ominus = -zFE_{\text{cell}}^\ominus$
	$\Delta G = \Delta G^\ominus + RT \ln Q$
Reaction quotient:	$Q = \frac{[\text{C}]^c [\text{D}]^d}{[\text{A}]^a [\text{B}]^b}$
For a reaction $a \text{ A} + b \text{ B} \rightleftharpoons c \text{ C} + d \text{ D}$	
Variation of the enthalpy with temperature:	$\Delta_r H^\ominus(T_2) = \Delta_r H^\ominus(T_1) + \Delta_r C_p^\ominus(T_2 - T_1)$
Variation of the entropy with temperature:	$\Delta_r S^\ominus(T_2) = \Delta_r S^\ominus(T_1) + \Delta_r C_p^\ominus \ln(T_2/T_1)$
Nernst equation:	$E = E^\ominus - \frac{RT}{zF} \ln \frac{c_{\text{red}}}{c_{\text{ox}}}$
Clausius-Clapeyron equation:	$\ln \frac{p_2}{p_1} = \frac{\Delta_{\text{vap}} H^\ominus}{R} \left( \frac{1}{T_2} - \frac{1}{T_1} \right)$
Kelvin equation:	$\ln \frac{p}{p_0} = \frac{2\sigma M}{\rho R T r}$
Temperature coefficient of standard cell potential:	$\frac{dE_{\text{cell}}^\ominus}{dT} = \frac{\Delta_r S^\ominus}{zF}$
Langmuir isotherm equation:	$\theta = aP/(1 + aP)$
Arrhenius equation:	$\ln k = \ln A - E_a/RT$
Integrated rate law:	
Zero order:	$[A] = [A]_0 - kt$
First order:	$\ln [A] = \ln [A]_0 - kt$



Second order:	$\frac{1}{[A]} = \frac{1}{[A]_0} + kt$
Half-life for a first order process:	$t_{1/2} = \ln 2/k$
Half-life for a second order process:	$t_{1/2} = \frac{1}{k[A]_0}$
Temperature dependence of the rate constant:	$\ln \frac{k_2}{k_1} = -\frac{E_a}{R} \left( \frac{1}{T_2} - \frac{1}{T_1} \right)$
Lambert–Beer equation:	$A = \epsilon lc$
Acidic effective coefficient	$\alpha_{Y(H)} = 1 + [H^+] \beta_1^H + [H^+]^2 \beta_2^H + \dots + [H^+]^6 \beta_6^H$
Coexisting ion effect coefficient	$\alpha_{Y(N)} = 1 + [N] K_{NY}$
Concentration of metal ion at stoichiometric point	$pM'_{sp} = 1/2(\lg K'_{MY} - \lg c_M^{sp})$

## Periodic table of the Elements

1 H 1.008																	18 He 4.003
3 Li 6.941	2 4 Be 9.012											13 5 B 10.81	14 6 C 12.01	15 7 N 14.01	16 8 O 16.00	17 9 F 19.00	10 Ne 20.18
11 Na 22.99	12 Mg 24.31	3	4	5	6	7	8	9	10	11	12	13 Al 26.98	14 Si 28.09	15 P 30.97	16 S 32.06	17 Cl 35.45	18 Ar 39.95
19 K 39.10	20 Ca 40.08	21 Sc 44.96	22 Ti 47.87	23 V 50.94	24 Cr 52.00	25 Mn 54.94	26 Fe 55.85	27 Co 58.93	28 Ni 58.69	29 Cu 63.55	30 Zn 63.38	31 Ga 69.72	32 Ge 72.63	33 As 74.92	34 Se 78.97	35 Br 79.90	36 Kr 83.80
37 Rb 85.47	38 Sr 87.62	38 Y 88.91	40 Zr 91.22	41 Nb 92.91	42 Mo 95.95	43 Tc -	44 Ru 101.1	45 Rh 120.9	46 Pd 106.4	47 Ag 107.9	48 Cd 112.4	49 In 114.8	50 Sn 118.7	51 Sb 121.8	52 Te 127.6	53 I 126.9	54 Xe 131.3
55 Cs 132.9	56 Ba 137.3	57-71	72 Hf 178.5	73 Ta 180.9	74 W 183.8	75 Re 186.2	76 Os 190.2	77 Ir 192.2	78 Pt 195.1	79 Au 197.0	80 Hg 200.6	81 Tl 204.4	82 Pb 207.2	83 Bi 209.0	84 Po -	85 At -	86 Rn -
87 Fr -	88 Ra -	89-103	104 Rf -	105 Db -	106 Sg -	107 Bh -	108 Hs -	109 Mt -	110 Ds -	111 Rg -	112 Cn -	113 Nh -	114 Fl -	115 Mc -	116 Lv -	117 Ts -	118 Og -

57 La 138.9	58 Ce 140.1	59 Pr 140.9	60 Nd 144.2	61 Pm -	62 Sm 150.4	63 Eu 152.0	64 Gd 157.3	65 Tb 158.9	66 Dy 162.5	67 Ho 164.9	68 Er 167.3	69 Tm 168.9	70 Yb 173.0	71 Lu 175.0
89 Ac -	90 Th 232.0	91 Pa 231.0	92 U 238.0	93 Np -	94 Pu -	95 Am -	96 Cm -	97 Bk -	98 Cf -	99 Es -	100 Fm -	101 Md -	102 No -	103 Lr -

# $^1\text{H}$ NMR

## Chemical shifts of hydrogen (in ppm/TMS)

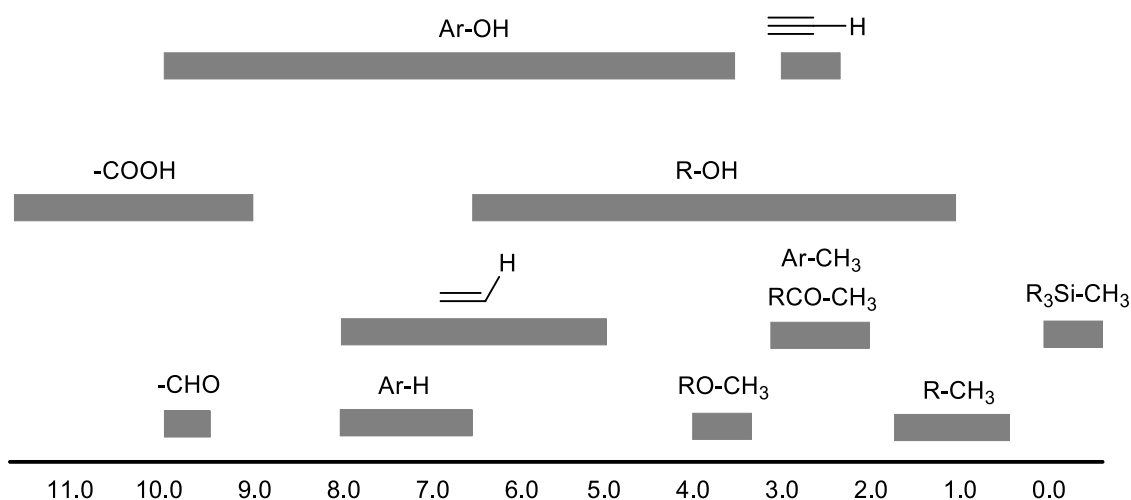

## H-H coupling constants (in Hz)

Hydrogen type	$ J_{ab} $ (Hz)
$\text{R}_2\text{CH}_a\text{H}_b$	4-20
$\text{R}_2\text{H}_a\text{C}-\text{CR}_2\text{H}_b$	2-12
$\text{RH}_a\text{C}=\text{CRH}_b$	cis: 7-12; trans: 12-18
$\text{R}_2\text{C}=\text{CH}_a\text{H}_b$	0.5-3
$\text{H}_a(\text{CO})-\text{CR}_2\text{H}_b$	1-3
$\text{RH}_a\text{C}=\text{CR}-\text{CR}_2\text{H}_b$	0.5-2.5

## IR spectroscopy table

Vibrational mode	$\sigma$ (cm <sup>-1</sup> )	Intensity
alcohol O—H (stretching)	3600-3200	strong
N—H (stretching)	3500-3350	strong
$\equiv\text{C}-\text{H}$ (stretching)	3300	strong
=C—H (stretching)	3100-3000	weak
C—H (stretching)	2950-2840	weak
C $\equiv$ N (stretching)	2250	strong
C $\equiv$ C (stretching)	2260-2100	variable
C=O (stretching)	1850-1690	strong
alkene C=C (stretching)	1680-1600	weak
aromatic C=C (stretching)	1600-1400	weak
CH <sub>2</sub> (bending)	1480-1440	medium
CH <sub>3</sub> (bending)	1465-1440; 1390-1365	medium
C—O—C (stretching)	1250-1050 (several)	strong
C—OH (stretching)	1200-1020	strong

## Visible Light Spectrum

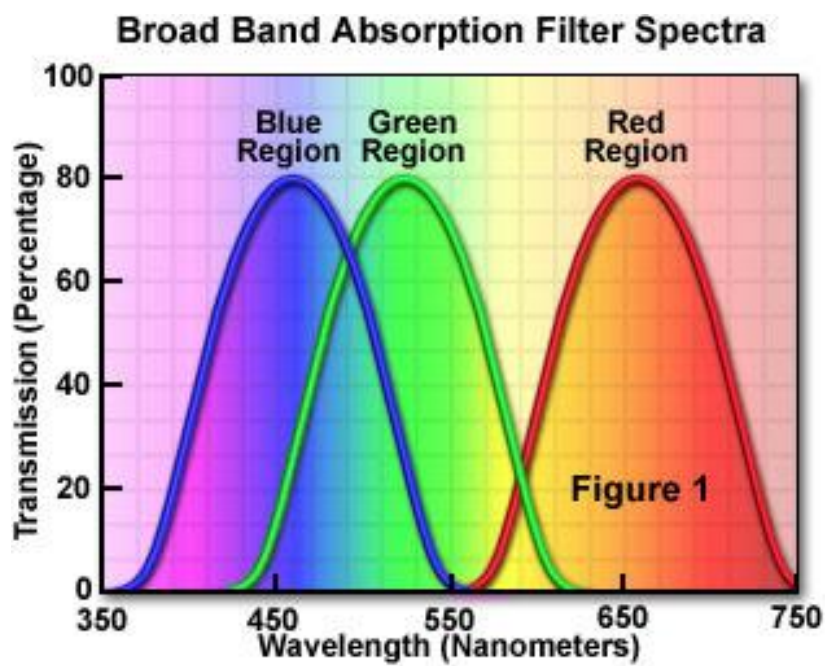

## **Theoretical problems**

## Problem 1. The Past and Present of Bronzeware

Bronzeware is one of the outstanding artefacts of human civilization. The earliest bronzes in China originated about 6000 years ago. The smelting of bronze had reached to a high technical level and the manufacture of bronzeware was common in the prosperous Shang and Zhou dynasties (ca. 1600 ~ 300 BC). "Hou Mu Wu" Ding (Figure 1.1), which was made in the late Shang Dynasty, is one of the most famous bronzes.



Figure 1.1 "Hou Mu Wu" Ding.

Copper was one of the earliest metals smelted by human beings. In the Earth's crust, copper is found mainly as the sulfide, oxide or carbonate, its major ores being chalcopyrite ( $\text{CuFeS}_2$ ), chalcocite ( $\text{Cu}_2\text{S}$ ), cuprite ( $\text{Cu}_2\text{O}$ ) and malachite ( $\text{Cu}_2\text{CO}_3(\text{OH})_2$ ). Although the abundance of iron in the Earth's crust is higher than that of copper, it was later before humans developed iron smelting technology.

**1-1** In the following statements, **indicate** which one is the main reason for the earlier recovery of copper:

- (a) Copper ore can be reached more easily than iron ore.
- (b) The melting point of copper is lower than that of iron.
- (c) The melting point of copper ore is lower than that of iron ore.

(d) The reaction temperature for the reduction of copper oxide by charcoal is much lower than that of iron ore.

Chalcopyrite ( $\text{CuFeS}_2$ ) is estimated to account for about 50% of all Cu deposits, and is widely used in copper smelting. The mineral powder is mixed with silica ( $\text{SiO}_2$ ), and calcined under an open atmosphere, giving rise to the elementary copper.

**1-2 Write** the equation for this reaction.

As an alloy of copper with other chemical elements such as tin and lead, bronze was also called "Gold" in ancient times, since recently cast bronzeware shows a golden color. However, bronzewares were covered by a layer of patina produced by oxidation over a long period. Due to the underground conditions experienced by bronzes that were buried, they were corroded to varying degrees, and various corrosion coatings naturally formed, including  $\text{CuO}$  (black),  $\text{Cu}_2\text{O}$  (red-brown), basic copper sulfates (blue-green, such as  $\text{Cu}_4\text{SO}_4(\text{OH})_6$ ,  $\text{Cu}_3(\text{SO}_4)(\text{OH})_4$ ) etc. The rusts brought out the surface appearance of bronzewares most striking characteristics. The layer generally does not change the shape of the bronzewares, and the nature of the patina is relatively stable so the wares are not usually damaged.

However, if bronze came into contact with the chloride-containing substances, CuCl and  $\text{Cu}_2(\text{OH})_3\text{Cl}$ , which is called “powder rust” could be formed, and this kind of patina caused “bronze disease” from the reactions: CuCl reacting with  $\text{O}_2$  and  $\text{H}_2\text{O}$ , giving rise to  $\text{Cu}_2(\text{OH})_3\text{Cl}$  and HCl (reaction 1). The formed  $\text{Cu}_2(\text{OH})_3\text{Cl}$  is not a dense phase and  $\text{O}_2$  penetrates the loose phase to reach and attack Cu in combination with HCl, resulting in the formation of CuCl and  $\text{H}_2\text{O}$  (reaction 2). The reactions took place repeatedly, till the wares were completely damaged.

**1-3 Write the chemical equations of reactions 1 and 2.**

In order to protect the precious bronzewares, various methods have been developed to remove the “Powder Rust”. One of the chemical methods used for treating large-area “powder rust” on bronzes is with carbonates: immerse the bronzewares into 1%-5%  $\text{Na}_2\text{CO}_3$  and  $\text{NaHCO}_3$  (1:1 molar ratio) solution (reaction 3). The cuprous chloride can be converted to Cu and  $\text{CuCO}_3$ . Another way to treat small rust is with  $\text{Ag}_2\text{O}$  ethanol paste, in which a simple ion exchange process occurs (reaction 4).

**1-4 Write the chemical equations of reactions 3 and 4.**

Blue vitriol ( $\text{CuSO}_4 \cdot 5\text{H}_2\text{O}$ ) can be prepared from waste bronzes (Cu-Sn-Pb alloy). Weigh a certain amount of bronze scraps, put the scraps into a beaker, and add concentrated nitric acid to the beaker carefully in a fume hood. During the reaction, a red-brown gas (**A**) is released, resulting in a mixture of blue-green solution (**B**) with a white precipitate (**C**). After filtration, add aqueous  $\text{H}_2\text{SO}_4$  solution to the filtrate, then a blue solution **D** and a white precipitate **E** are formed. Concentrate the solution **D** and blue crystallites, the crude product (**F**) can be obtained by cooling the solution.

**1-5-1 Write the chemical formula of A, C, E and F.**

**1-5-2 Write the main anions and cations in the solutions B and D respectively.**

In order to test the purity of the product, a 0.2765 g sample is weighted into a 250 mL iodometric flask and dissolved by buffer solution. 1 g KI is added to the flask and the mixture is kept in the dark for 10 min (reaction 5) after shaking for 10 seconds. After dilution by the addition of water, the solution is titrated with  $0.05036 \text{ mol dm}^{-3}$   $\text{Na}_2\text{S}_2\text{O}_3$  standard solution (reaction 6) and 20.80 mL of  $\text{Na}_2\text{S}_2\text{O}_3$  standard solution is consumed at the end point.

**1-6-1 Write the ionic equations of reaction 5 and reaction 6.**

**1-6-2 Calculate the purity of the prepared Blue vitriol.**

Thermogravimetric analysis of  $\text{CuSO}_4 \cdot 5\text{H}_2\text{O}$  is performed, and its weight change with temperature is shown in Figure 1.2.

**1-7 Identify** the substance(s) which leaving at the three steps of the weight loss, and **estimate** their molar ratio by calculation.

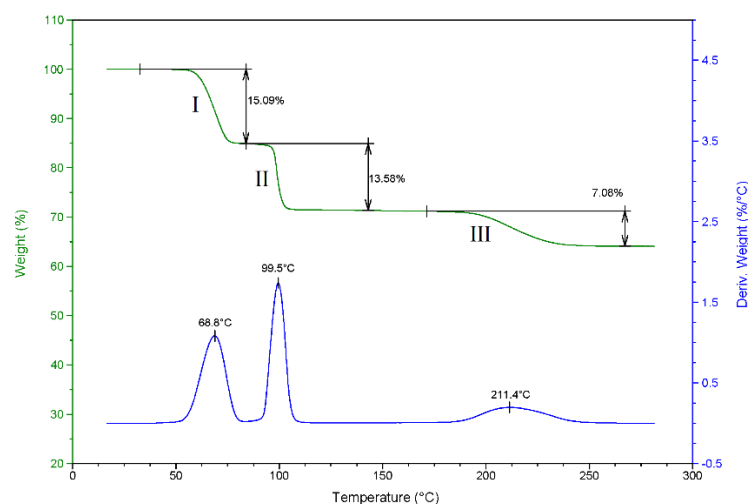

Figure 1.2: Thermogravimetric curve of  $\text{CuSO}_4 \cdot 5\text{H}_2\text{O}$

## Problem 2. The Chemical Element in Mysterious Elixir

In Chinese,  $\text{As}_4\text{S}_4$ ,  $\text{As}_2\text{S}_3$  and  $\text{As}_2\text{O}_3$  are called realgar, orpiment, and arsenolite respectively. They and sulfur ( $\text{S}_8$ ) are “the Four Yellows” of ancient Chinese alchemical materials.

**2-1**  $\text{As}_4\text{S}_4$  has two isomers ( $\text{As}_4$  has a similar structure to  $\text{P}_4$ ). The four As atoms in a realgar molecule have the same chemical environment, the ones in the other isomer have three different chemical environments. **Draw** the schematic diagram of the structures of the two isomers (there is no S-S bond).

**2-2** Orpiment is the associated mineral of realgar, they are said to be “Aix galericulata” in the mineral world. When co-heated with KOH, weakly acidic orpiment reacts with KOH to form two salts, while realgar (under catalysis by strong alkali) disproportionates to orpiment and arsenic, which then continue to react with KOH. However, ammonium bicarbonate solution can distinguish between orpiment and realgar. **Express** how they can be identified in principle by reaction equation (Disregarding the hydrolysis of salt).

Arsenolite is a highly toxic substance. In 1821, Napoleon, the former emperor of France, died in St. Helena. The official report is that he died of stomach cancer, but scientists and historians have questioned the conclusion repeatedly over the last two centuries. In 1961, samples of Napoleon's hair were analyzed and an arsenic content that exceeded the limit by 100 times was found, leading to speculation that the wine he drank had been poisoned with arsenic by his cronies for a long time.

**2-3-1** In 1832, the English chemist James Marsh devised a procedure for detecting arsenic -- Marsh's test, which involves the following steps: (a) Adding hydrochloric acid and zinc particles to the sample. If  $\text{As}_2\text{O}_3$  is present, a toxic gas (polar molecule with pyramidal structure) will be produced (Reaction 1). (b) When the toxic gas is heated in a tube, a shiny black material is deposited on the wall of the tube (Reaction 2), which could be dissolved by washing with sodium hypochlorite solution (Reaction 3). The sensitivity of this method for arsenic detection was  $7\mu\text{g}$ . **Write** the equations of Reaction 1, 2 and 3.

**2-3-2** In order to simplify the experimental operation and increase the sensitivity, the Gutzeit's arsenic



test can be used. In this method, the gas produced by Reaction 1 directly reacts with silver nitrate solution to form a black precipitate. (Sensitivity is  $5\mu\text{g}$ ). **Write** the reaction equation between the gas and silver nitrate.

**2-3-3** In fact, the arsenic in Napoleon's hair was detected using a technique called neutron activation in the 1960s.  $^{75}\text{As}$  transforms to  $^{76}\text{As}$  by absorbing a high-energy neutron while emitting characteristic  $\gamma$  rays, and the intensity of the rays establishes how much arsenic is present in a sample. The sensitivity of this method is up to 5 ng. **Write** the equation for the nuclear reaction.

**2-3-4** Thus, the claim that Napoleon was murdered seemed to be confirmed. However, in the 1990s, scientists discovered that Scheele's green ( $\text{CuHAsO}_3$ ) was contained in wallpapers of the green luxury rooms where Napoleon lived. It was speculated that Napoleon was not murdered by a person, but by moldy wallpapers caused by the hot and humid climate of St. Helena, which made Scheele's green produce a volatile compound. **What** might this volatile compound be?

**2-3-5** In fact, green mineral pigments are mostly copper-containing arsenites. In addition to Scheele's green, there is also Paris green ( $\text{Cu}(\text{CH}_3\text{CO}_2)_2 \cdot 3\text{Cu}(\text{AsO}_2)_2$ ). In Paris green, the  $\text{AsO}_2^-$  meta-arsenite ion shows a ring-like trimeric structure. Whereas the  $\text{AsO}_3^-$  meta-arsenate ion is a long zigzag chain structure with  $\text{AsO}_4$  tetrahedra repeated alternately in  $\text{LiAsO}_3$ . **Draw** the multimeric structures of the two anions.

**2-3-6** As a white pigment, the durability of  $\text{ZnO}$  is better than that of  $\text{Pb}(\text{OH})_2 \cdot 2\text{PbCO}_3$ , because after encountering atmospheric sulfides, the former ( $\text{ZnO}$ ) transforms into white  $\text{ZnS}$ , while the latter transforms into black  $\text{PbS}$ . Similarly, Scheele's green and Paris green are susceptible to darkening in the presence of sulfides. **What** substance may be generated when they turn black?

**2-3-7**  $\text{As}_2\text{O}_3$  is the anhydride of arsenous acid, which may be present as  $[\text{AsO}(\text{OH})_2]^-$ ,  $[\text{AsO}_2(\text{OH})]^{2-}$ ,  $[\text{AsO}_3]^{3-}$  in alkaline solution. Thus,  $\text{H}_3\text{AsO}_3$  is a \_\_\_\_\_ protic acid.

**2-3-8** Dissolve 5.00 g  $\text{As}_2\text{O}_3$  ( $M_r = 197.84$ ) and 6.00 g  $\text{NaOH}$  in  $20\text{ cm}^3$  deoxygenated water, and add 1.44 g sulfur ( $M_r = 32.06$ ), then heat to  $100\text{ }^\circ\text{C}$  in a reflux device for 2 h. After filtering the excess elemental sulfur from the solution, the solution is cooled down to below  $4\text{ }^\circ\text{C}$ . After drying under vacuum, filter the obtained crystals and then dissolve them in deoxygenated water again. Add ethanol to recrystallize (the percentage loss of sulfur is 13.3%), filter and dry to obtain 13.66 g of crystals (only one substance). The chemical formula of the crystals is \_\_\_\_\_?

### Problem 3. Cyanotype, Prussian blue and Related Compounds

In the development of pigments, Prussian Blue (PB, also known as Berlin Blue) occupies an important position. Prussian blue has high coloring ability and has been widely used to color paints, inks, textiles, and other commercial products. Despite the presence of cyanide groups, the pigment is not toxic. Until the 1970s, it was prominent in the paint industry.

The blue substance is generally considered as ferric ferrocyanide  $\text{Fe}_4[\text{Fe}(\text{CN})_6]_3$ , and there are various members in the family formed by  $\text{Fe}^{\text{II}}\text{-Fe}^{\text{III}}\text{-CN}^-$ , for instances, Turnbull's Blue (TB), Prussian Green (PG) or Berlin Green (BG), Prussian Brown (PBr), William White (WW). The typical method for the preparation of Prussian blue is by the reaction of ferric cations  $\text{Fe}^{3+}$  with potassium hexacyanoferrate ( $\text{K}_4[\text{Fe}(\text{CN})_6]$ ). Therefore,  $\text{K}^+$  is often involved in the formation of the product, and the resulting blue material is a fine particulate and is easy to disperse, so it is called "soluble" Prussian blue ( $\text{KFe}[\text{Fe}(\text{CN})_6]$ ). If without  $\text{K}^+$ , it is easy to precipitate, then the product is called "insoluble" Prussian blue.

Several members in the complex family of  $\text{Fe}^{\text{II}}\text{-Fe}^{\text{III}}\text{-CN}^-$  can be prepared by applying different substances as the reagents, as shown.

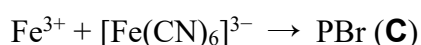
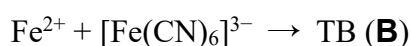
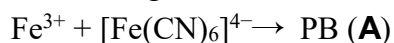

**3-1** If **A**, **B** and **C** are  $\text{K}^+$ -free, while **D** contains appropriate amount of  $\text{K}^+$  cations which enables the stoichiometric ratio of  $\text{Fe}^{2+} + [\text{Fe}(\text{CN})_6]^{4-}$  being 1:1. Write the chemical formula of the products. (Water molecules can be omitted.)

The structure of Prussian blue is intriguing. It seems simple but in fact very diverse. It belongs to the cubic system and has three-dimensional regular pores. The pores can host water molecules and metal ions. The structure of  $\text{KFe}[\text{Fe}(\text{CN})_6]$  is shown in Fig. 3.1.

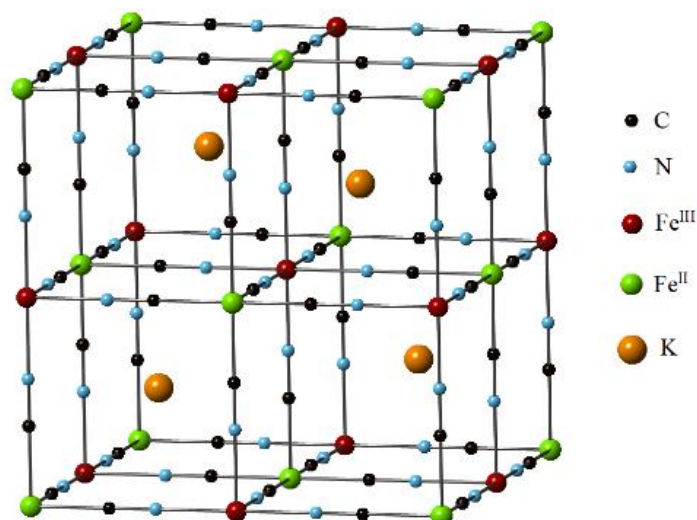

Figure 3.1 Unit cell of Prussian Blue  $\text{KFe}[\text{Fe}(\text{CN})_6]$   
**Fe(III)-red** **Fe(II)-green** **K-Orange** **C-Black** **N-blue**

In Fig. 3.1, the alternately distributed high-spin Fe<sup>III</sup> and low-spin Fe<sup>II</sup> are connected by cyanide ligands (Fe<sup>II</sup>-C≡N-Fe<sup>III</sup>), forming the network structure, and the 1/2 cubic holes in the structure are occupied by K<sup>+</sup> cations which also balance the negative charge of the framework. The blue color is due to the charge transfer between Fe<sup>III</sup> and Fe<sup>II</sup> through the cyanide bridges. If there are no K<sup>+</sup> cations in the cubic holes, the iron cations in the framework are all in +3 oxidation state, and the corresponding compound is called Prussian Brown.

**3-2 Draw** the electron configurations of high-spin Fe<sup>III</sup> and low-spin of Fe<sup>II</sup> in the octahedral ligand field, and **indicate** which cation (Fe<sup>III</sup> or Fe<sup>II</sup>) has a larger crystal field splitting energy Δ<sub>o</sub>.

**3-3** Prussian Blue with the chemical formula exactly the same with **A** also takes the similar cubic structure but with defects in the framework. **Determine** the number of atoms (specify the type) or group (cyanide) in each unit cell and **indicate** the type of defects.

The complexes in the family of Fe<sup>II</sup>-Fe<sup>III</sup>-CN<sup>-</sup> are sensitive to light and under irradiation they can transformation, and cyanotype was developed. A typical procedure is as follows:

(1) Prepare two solutions: 20% ferric ammonium citrate solution (**E**) and 10% potassium ferricyanide solution (**F**).

(2) Mix **E** and **F** in equal volumes, and a dark yellow-green mixture (Prussian Brown) is obtained.

(3) Brush the above mixture on the surface of a carrier such as paper, textile or even porcelain. Let it form a uniform thin layer and dry it in the atmosphere.

(4) Put a negative film that needs to be developed on the surface of the carrier and clamp them tightly.

(5) Expose them under the sunlight or a suitable light source for a certain time.

During irradiation, especially with ultraviolet radiation, Fe<sup>III</sup> in the Prussian Brown is partially reduced. Prussian Blue (PB) is formed and deposits on the carrier. The materials in the area that is not irradiated do not participate in the reaction, and can be dissolved in water and washed away, meaning a distinctive blue photo can be obtained by the deposits. If the exposure time is too long, the Prussian blue may be further reduced to form William White (WW), here the formed WW occludes K<sup>+</sup> within its pores.

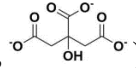
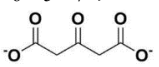
**3-4** During the cyanotype process, citrate (C<sub>6</sub>H<sub>5</sub>O<sub>7</sub><sup>3-</sup>, ) acts as a reducing agent. If it releases a carbon dioxide and turns into (C<sub>5</sub>H<sub>4</sub>O<sub>5</sub><sup>2-</sup>, ) , and the resulting PB structure takes the structure as that shown in Figure 3.1. **Write** the chemical equations for the formation of Prussian Blue and its transformation into William White during the process. (Ignore water)

Many transition metals M1 and M2 (such as Mn, Co, Ni, and even Fe) cations can bind through CN<sup>-</sup> to form the similar cubic porous network structure, and those compounds are called Prussian Blue Analog (PBA). The valence states of transition metals M1 and M2 are usually +2 and +3. The composition and structure of PBA can be adjusted by varying the synthetic method and the initial materials. Electron transfer can occur between M1 and M2 through the CN groups, and the alkali metal ion can fill the holes of the cube, which enables PBA to show special properties such as ion

adsorption and storage, redox, catalysis and so on.

**3-5-1** Dark red Co-PBA precipitate is prepared by mixing potassium aqueous solutions of ferricyanate  $[\text{K}_3\text{Fe}(\text{CN})_6]$  and cobalt chloride ( $\text{CoCl}_2$ ). **Write** the formula of product (**G**) that is an analog of that shown in Fig. 3.1.

**3-5-2** The magnetic measurement reveals that Complex **G** has very weak paramagnetism at a low temperature of 15 K, but its magnetism is significantly enhanced under red light irradiation. Identify **which** of the following statement(s) provide(s) the information related with the magnetic phenomena of **G**:

- (a) In the as-prepared **G**, the oxidation numbers of cobalt and iron are +2 and +3 respectively;
- (b) In the as-prepared **G**, the oxidation numbers of cobalt and iron are +3 and +2 respectively;
- (c) Under irradiation, the transition from  $\text{Fe}^{\text{II}}-\text{C}\equiv\text{N}-\text{Co}^{\text{III}}$  to  $\text{Fe}^{\text{III}}-\text{C}\equiv\text{N}-\text{Co}^{\text{II}}$  occurs;
- (d) Under irradiation, the transition from  $\text{Fe}^{\text{III}}-\text{C}\equiv\text{N}-\text{Co}^{\text{II}}$  to  $\text{Fe}^{\text{II}}-\text{C}\equiv\text{N}-\text{Co}^{\text{III}}$  occurs;
- (e) Under irradiation, the transition of electrons from  $t_{2g}$  to  $e_{2g}$  of the metal cations occurs;
- (f) In the above two cases, these two kinds of cations (cobalt and iron) are all in low spin states;
- (g) In the above cases, these two kinds of cations (cobalt and iron) are all in high spin states;
- (h) In the as-prepared **G**, these two kinds of cations (cobalt and iron) are all in low spin states, but under irradiation, they are in high spin states.

During the past decade, Prussian blue and its analogs found a common use. Their ability to transfer electrons efficiently and occlude ions within the structure makes it an ideal substance for use in ion battery electrodes.  $\text{K}^+$  in the holes of PB or PBA can be replaced by  $\text{Na}^+$ , then PBA can be used as the positive electrode material in a sodium ion battery, where metallic sodium is used as the negative electrode. The research shows that the less common the defects in PBA, the better the storage performance of the material.

**3-6-1** In the search for an ideal electrode materials,  $\text{Na}_2\text{Fe}(\text{CN})_6$  and  $\text{CoCl}_2$  aqueous solutions are applied and mixed to get the precipitate under controlled conditions. **Write** the formula of the vacancy-free product (**H**).

**3-6-2** **Write** the reversible equations of charge and discharge of the sodium ion battery with **H** as the positive electrode material, and metallic sodium as the negative electrode.

## Problem 4. Painted Sculpture “Clay Figure Zhang”

The “Clay Figure Zhang” is a kind of local folk painted sculpture in Tianjin, which emerged in the late Qing Dynasty more than 180 years ago. This type of clay figure is made from mud with low sand content and other impurities, which is mixed with smashed cotton wadding, and kneaded repeatedly to form "cooked mud" after the procedures of weathering, beating, filtration and dehydration. The "cooked mud" is then shaped to design the "clay figure", thoroughly dried by natural air, and then calcined in the kiln at about 700 °C. After carefully polishing and coloring, the final “Clay Figure Zhang” sculpture is obtained.



During processing, a certain amount of  $\text{NH}_4\text{H}_2\text{PO}_4$  and  $\text{MgO}$  are added to form Struvite (reaction 1), which is beneficial to shorten the drying time and avoid the cracking of the mud. Struvite can crystallize in an orthorhombic crystal system, (Figure 4.1).

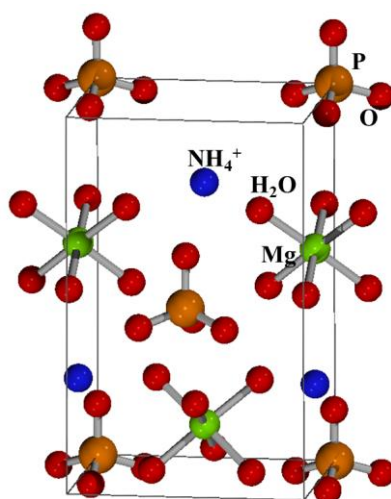

Figure 4.1 The crystal structure of Struvite.

**4-1-1 Write** the equation of reaction 1.

**4-1-2** The unit cell parameters are:  $a = 694.1$  pm,  $b = 613.7$  pm,  $c = 1119.9$  pm. **Calculate** the density

of Struvite.

**4-2** The silicon content in the mud can be determined by the following methods: weigh  $x$  g sample and mix with  $\text{NH}_4\text{Cl}$  (8 times the amount of the sample), drop concentrated hydrochloric acid to wet the samples, and add 2 to 3 drops of concentrated nitric acid. After heating the sample to decompose completely, hot water is added to dissolve the soluble salt, filter, and wash. The precipitate (**A**) is put in a crucible and burned to a constant weight, thus affording a solid  $y$  g. Write the chemical formula of **A**, and give an expression for the silicon content.

**4-3** The chemical properties of the alkali metal element **M** are similar to those of magnesium. When **M** is ignited in air, both **B** and **D** are obtained. Then **B** reacts with water to form **E** and irritating gas **F**. Write the chemical formulae of **B**, **D**, **E**, and **F**.

**4-4** Carbonates of alkaline earth metal can be decomposed by heating, hence affording the corresponding oxides. Calculate the minimum decomposition temperature of magnesium carbonate. Related thermodynamic data are provided, as follows:

	$\text{MgCO}_3$	$\text{MgO}$	$\text{CO}_2$
$\Delta_f H_m^\ominus$ (298K) ( $\text{kJ mol}^{-1}$ )	-1095.8	-601.6	-393.5
$\Delta_f G_m^\ominus$ (298K) ( $\text{kJ mol}^{-1}$ )	-1012.1	-569.3	-394.4
$S_m^\ominus$ (298K) ( $\text{J mol}^{-1} \text{K}^{-1}$ )	65.7	27	213.8

## Problem 5 Chinese Cloisonné

Chinese Cloisonné has been known as a treasure of Chinese art for more than 600 years since Ming Dynasty. Chinese cloisonné enamelware is made by covering thin layers of enamel on metal objects such as brass or bronze vases, kettles, or other objects. The enamel layer is colored with metal oxides (mainly cobalt oxide), which exhibits brilliant colors such as blue, which originate from the cobalt compounds.



**5-1**  $\text{Co}^{2+}$  reacts with alkali to form a blue precipitate (1), which is easily oxidized (2). The oxidation product reacts with hydrochloric acid to release yellow-green gas (3). Write the equations of reactions (1) to (3).

**5-2** Cobalt dichloride can react with ammonia under different conditions to produce four complexes with different colors: **A**.  $\text{CoCl}_3 \cdot 6\text{NH}_3$  (orange), **B**.  $\text{CoCl}_3 \cdot 5\text{NH}_3$  (red purple), **C**.  $\text{CoCl}_3 \cdot 4\text{NH}_3$  (violet), **D**.  $\text{CoCl}_3 \cdot 3\text{NH}_3$  (green). When a sufficient amount of  $\text{AgNO}_3$  (aq) is added, the ratio of  $\text{Ag}^+$  consumed by **A**, **B**, and **C** is 3:2:1, and **D** does not react. Write the formulas for complexes **A**, **B**, **C**, and **D** based on inner/outer sphere.

When dissolving  $\text{CoCl}_2$  in a concentrated  $\text{HCl}$  solution, the following color change is observed along with a temperature change :

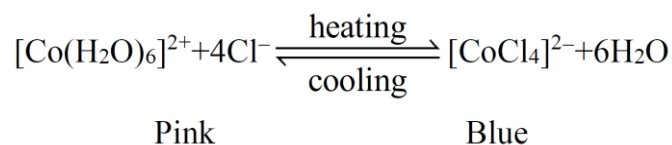

**5-3-1 Which** absorption spectrum shown in Figure 5.1 should be assigned to the solution at high temperature?

(a) I

(b) II

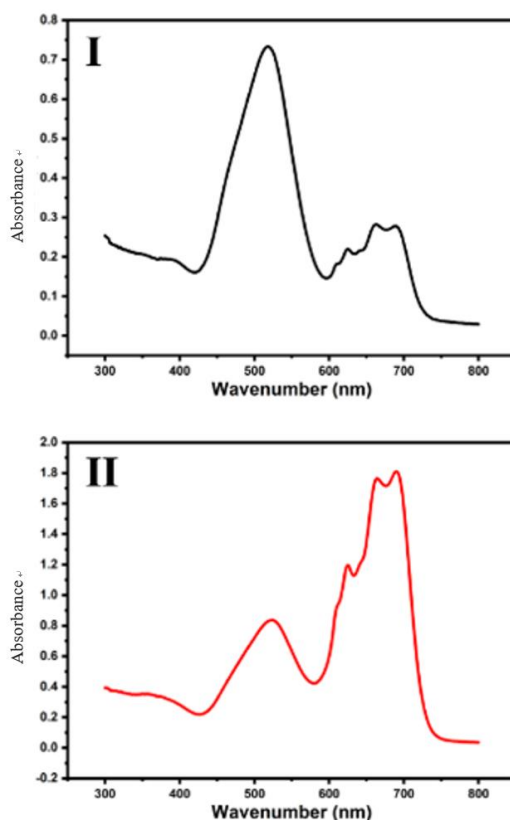

Figure 5.1 Absorption spectra of the solutions of  $[\text{Co}(\text{H}_2\text{O})_6]^{2+}$  and  $[\text{CoCl}_4]^{2-}$

**5-3-2 Draw** the configurations of  $d$  electrons of the cobalt ion in these two coordination ions with different color, respectively.

**5-3-3** Coordination compounds/ions exhibit paramagnetism when containing unpaired electrons, and the corresponding magnetic moment ( $\mu$ ) is calculated by the function  $\mu = \sqrt{n(n+2)}\mu_B$  where  $n$  is the number of the unpaired electrons. **Calculate** the value of  $\mu$  for the coordination ion  $[\text{Co}(\text{H}_2\text{O})_6]^{2+}$ .

Put an aluminum plate covered by its oxide layer into a dilute cobalt nitrate solution for a while, take out the plate and burn it in the flame of a Bunsen burner for minutes. A blue substance can be observed on the surface. The blue substance, known as cobalt blue, is  $\text{CoAl}_2\text{O}_4$  with a spinel structure. The general formula of spinel is expressed as  $\text{AB}_2\text{O}_4$ , where oxygen ions arrange in a cubic close packing pattern, **A** cations occupy the tetrahedral holes formed by oxygen ions, and **B** cations take the octahedral holes, as shown in Figure 5.2.

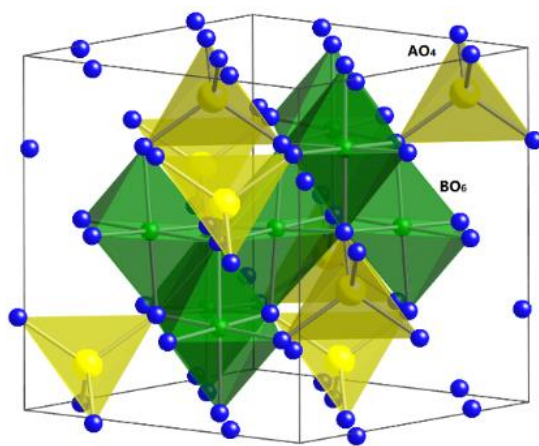

Figure 5.2 Structure of spinel  $AB_2O_4$

5-4 Regarding the cations and their position which is responsible for blue color, **choose** all correct statements for cations.

- (a)  $Co^{2+}$  is in a tetrahedral ligand field.
- (b)  $Co^{2+}$  is in an octahedral ligand field.
- (c)  $Al^{3+}$  is in a tetrahedral ligand field.
- (d)  $Al^{3+}$  is in an octahedral ligand field.

## Problem 6. Titanium is awesome

Titanium, as a silver-white transition metal, was named after Titans who, in Greek mythology, were the children of Heaven and Earth condemned to living amongst the hidden fires of the earth. Titanium has been widely used in high-tech society, especially in the aircraft industry and marine equipment, due to its corrosion resistance and mechanical properties, coupled with its relatively low density. Though it is abundant in nature, in the past titanium had been considered a rare metal due to its diffuse distribution in the Earth's crust and its difficulty to extract.

Panzhihua, a city in Sichuan province of China, and named after the tree *Bombax malabaricum* with very beautiful red flowers on its stalk, is known as the "Vanadium and Titanium Capital of China", since there are large amounts of titanium, vanadium and iron ore deposits.

Titanium dioxide ( $TiO_2$ ) is an important white pigment that has wide applications in coatings, plastics, papermaking, printing inks, chemical fiber, rubber, cosmetics and other industries. An important industrial process called the "sulfate process" for producing titanium dioxide from the mineral containing ilmenite ( $FeTiO_3$ ) is shown as in Figure 6.1:

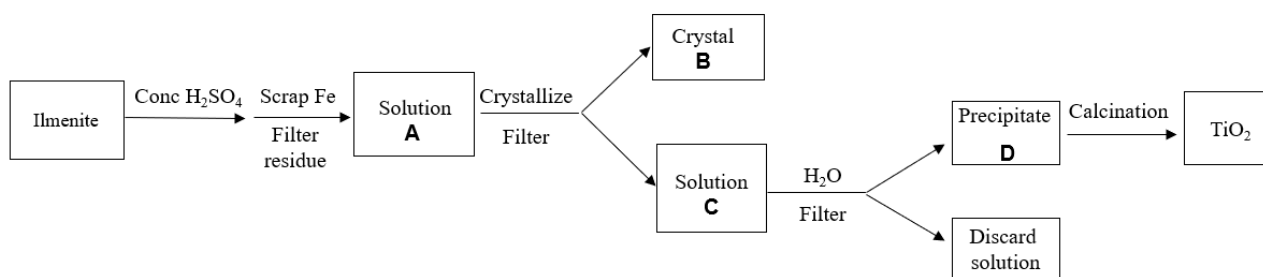

Figure 6.1 Scheme for preparation of  $TiO_2$  by the sulfate process



**6-1-1 Write** the main ions in solution **A**.

**6-1-2 Write** the formula for **B**.

**6-1-3 Write** the chemical equation that produces precipitate **D**.

An alternative method for the production of titanium dioxide from ilmenite is the “chloride process”, which involves selective chlorination of ilmenite with chlorine in the presence of a controlled amount of carbon at temperature of 900~1000 °C.

**6-2 Write** the chemical equation.

Titanium white can also be prepared by the following method: rutile or titanium-rich material is crushed, dried and mixed with carbon powder, then the mixture reacts with Cl<sub>2</sub> in a chlorination furnace to yield titanium tetrachloride (**reaction 1**); and then oxidation is carried out in the gas-phase oxidation furnace to yield titanium dioxide (**reaction 2**).

**6-3-1 Write** the equations of reactions **1** and **2**.

**6-3-2 Explain** why carbon is required in reaction **1** by calculation using the following thermodynamic data at 298 K.

	$\Delta_f H_m^\ominus / \text{kJ mol}^{-1}$	$S_m^\ominus / \text{J mol}^{-1} \text{K}^{-1}$
TiO <sub>2</sub>	-944.0	50.6
TiCl <sub>4</sub>	-804.2	252.3
CO	-110.5	197.7
O <sub>2</sub>	0	205.2
Cl <sub>2</sub>	0	223.1
C(graphite)	0	5.7

Nano-sized TiO<sub>2</sub> shows antibacterial, self-cleaning and anti-aging properties, which can be used in cosmetics, functional fibers, plastics, inks, coatings, paints, fine ceramics and other fields. The content of TiO<sub>2</sub> in titanium pigment can be determined by the following method. A 0.2022 g sample is weighed and dissolved in (NH<sub>4</sub>)<sub>2</sub>SO<sub>4</sub> and H<sub>2</sub>SO<sub>4</sub> solution. After complete dissolution of the sample by heating, the sample solution is diluted by addition of water and HCl solution, then reduced with metal Al sheet under a CO<sub>2</sub> atmosphere. After the reaction is completed (Al sheet completely dissolved), the sample solution is titrated by NH<sub>4</sub>Fe(SO<sub>4</sub>)<sub>2</sub> standard solution (0.08770 mol L<sup>-1</sup>) immediately with KSCN as indicator. 28.30 mL NH<sub>4</sub>Fe(SO<sub>4</sub>)<sub>2</sub> standard solution is consumed at the ending-point.

**6-4-1 Write** the ionic reaction equation for the reduction of Ti(IV) by Al.

**6-4-2 Calculate** the content of TiO<sub>2</sub> in the sample.

Perovskite originally referred to CaTiO<sub>3</sub> mineral and later represented the family of compounds having similar crystallographic structure. The formula of a typical perovskite compound can be expressed as ABX<sub>3</sub>, where A and B are cations and X refers to non-metal elements. X and larger cation A form the cubic close packing, and the smaller B cation occupies the center of the octahedron

formed only by X anions.

**6-5-1** BaTiO<sub>3</sub> adopts a perovskite structure, It is a typical ferroelectric material with high dielectric constant and piezoelectric properties. One of the methods to prepare BaTiO<sub>3</sub> includes the following procedures: (1) equal amounts of BaCl<sub>2</sub> and TiCl<sub>4</sub> coprecipitate with oxalic acid as a precipitant; (2) the precipitate is collected, washed, dried, and pyrolyzed to yield BaTiO<sub>3</sub>. **Write** the main chemical reaction equations for the above process.

**6-5-2** In recent years, a new family of perovskite-structure solar cell materials based on organic/inorganic hybrid components has attracted intensive interest. These compounds are characterized by a wide spectral response and considerable photoelectric conversion efficiency. A representative compound of this group is CH<sub>3</sub>NH<sub>3</sub>PbI<sub>3</sub>. **Select** the correct description(s) from the following items which may present the oxidation state of Pb and its site in the perovskite structure.

- (a) The oxidation state of lead is +3.
- (b) The oxidation state of lead is +2.
- (c) The lead atom resides in the center of the octahedron surrounded by I<sup>-</sup> ions
- (d) The lead atom resides in the center of the cuboctahedron surrounded by I<sup>-</sup> ions

## Problem 7. Kaolinite and Sodalite

(The requirement for the knowledge of silicates and zeolites are limited to this Problem. There is no need to extend much more.)

Kaolinite is an important clay mineral in nature. It was formed by various geological processes such as hydrothermal alteration, weathering and deposition. As one of the most important raw materials for the ceramics industry, kaolinite from Jingdezhen, Jiangxi Province, China is famous for its high quality. The international name of kaolinite originated in 1867 from the mountain near Gaoling Village in the northern area of Jingdezhen. It is also called China clay. The porcelain produced in Jingdezhen represented the high level of Chinese ceramics.

The chemical formula of kaolinite is Al<sub>2</sub>Si<sub>2</sub>O<sub>5</sub>(OH)<sub>4</sub> (or 2SiO<sub>2</sub>·Al<sub>2</sub>O<sub>3</sub>·2H<sub>2</sub>O). From the structural aspect, it belongs to the 1:1 type layered silicates composed of Si<sub>2</sub>O<sub>5</sub><sup>2-</sup> tetrahedral layers and Al<sub>2</sub>O<sub>2</sub>(OH)<sub>4</sub><sup>2-</sup> octahedral layers. Therein, each SiO<sub>4</sub> tetrahedron shares 3 vertices to form a two-dimensional layer containing characteristic six-membered rings with all the unshared oxygen atoms pointing to the same side of the layer, as shown in Figure 7.1a. The aluminum-oxygen octahedral layer possesses two layers of oxygen atoms arranged in near close packing with aluminum ions occupying 2/3 of the octahedral holes formed by oxygen atoms, showing a honeycomb-like pattern (Figure 7.1b). The silicon-oxygen tetrahedral layer Si<sub>2</sub>O<sub>5</sub><sup>2-</sup> and the aluminum-oxygen octahedral layer Al<sub>2</sub>O<sub>2</sub>(OH)<sub>4</sub><sup>2-</sup> share the oxygen atoms towards the same side of tetrahedral layer (Figure 7.1c and d) to form a composite layer of kaolinite. The combination of the rest of the oxygen atoms with protons in the octahedral layer maintains the electronic neutrality of the mineral.

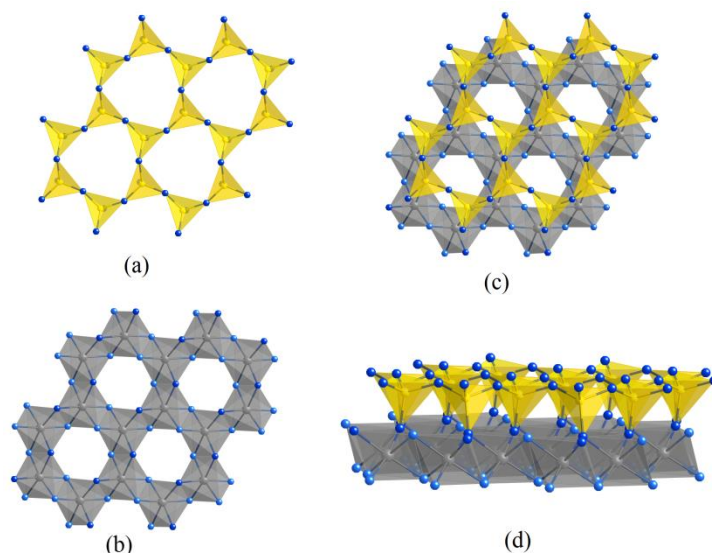

Figure 7.1: Structure of Kaolinite

(a)  $\text{Si}_2\text{O}_5^{2-}$  tetrahedral layer, (b)  $\text{Al}_2\text{O}_2(\text{OH})_4^{2-}$  octahedral layer, (c) and (d) Composite layer

The weathering of feldspar is one of the effective ways for the formation of kaolinite. For example, potassium feldspar ( $\text{K}_2\text{Al}_2\text{Si}_6\text{O}_{16}$ ) can be transformed into kaolinite under the cooperative action of  $\text{H}_2\text{O}$  and  $\text{CO}_2$ .

**7-1 Write** the chemical equation of the above transformation.

If  $\text{Al}^{3+}$  cations and octahedral holes in the octahedral layer in kaolinite are replaced by  $\text{Mg}^{2+}$  cations, another kind of 1:1 mineral, chrysotile is obtained.

**7-2 Write** the chemical formula of chrysotile.

The changes of kaolinite on heating generally undergo the following three stages:

Stage 1: It loses water totally and turns into metakaolinite at  $550\sim 600\text{ }^\circ\text{C}$ ;

Stage 2: Two equivalents of metakaolinite react at  $900\sim 960\text{ }^\circ\text{C}$ , giving rise to equal amount of an aluminosilicate phase (**S**) and active silica. **S** has a defective spinel structure. The prototype of the ideal spinel structure is  $\text{MgAl}_2\text{O}_4$ , and the general formula of spinel is expressed as  $\text{AB}_2\text{O}_4$ , where A represents cation at the tetrahedral position and B is the cation at octahedral position. In **S**, the occupancy of A position is  $3/4$ , the occupancy of B position is only  $2/3$ , and the oxygen position are fully occupied.

Stage 3: **S** further decomposes into mullite ( $\text{Si}_2\text{Al}_6\text{O}_{13}$ ) and cristobalite ( $\text{SiO}_2$ ) at  $1000\sim 1100\text{ }^\circ\text{C}$ .

**7-3-1 Write** the formula of **S**.

**7-3-2 Write** the chemical equations of the three stages of kaolinite respectively.

Kaolinite can also be used as a source of silica and alumina for the synthesis of zeolites, and the zeolites with framework codes of **FAU**, **LTA**, and **SOD** have been obtained by applying kaolinite as one of the starting materials under hydrothermal conditions. These types of zeolite frameworks have a common feature: they all contain sodalite cages.

Conventional zeolites are crystalline aluminosilicates with the rigid framework built from

vertex-sharing  $\text{TO}_4$  ( $T = \text{Si}, \text{Al}$ ) tetrahedra, and through the frameworks run tunnels and characteristic pores which can be accessible from the surface of the crystals. Foreign ions and molecules can therefore occlude inside the pores and/or channels, and their entering or leaving the crystal does not disturb the framework. The typical values of Si-O bond length and O-Si-O bond angles of  $\text{SiO}_4$  are 162 pm and  $109.5^\circ$  respectively, while the common Si-O-Si bond angle is about  $145^\circ$ , which is considered as one of the key factors for constructing the porous structure.

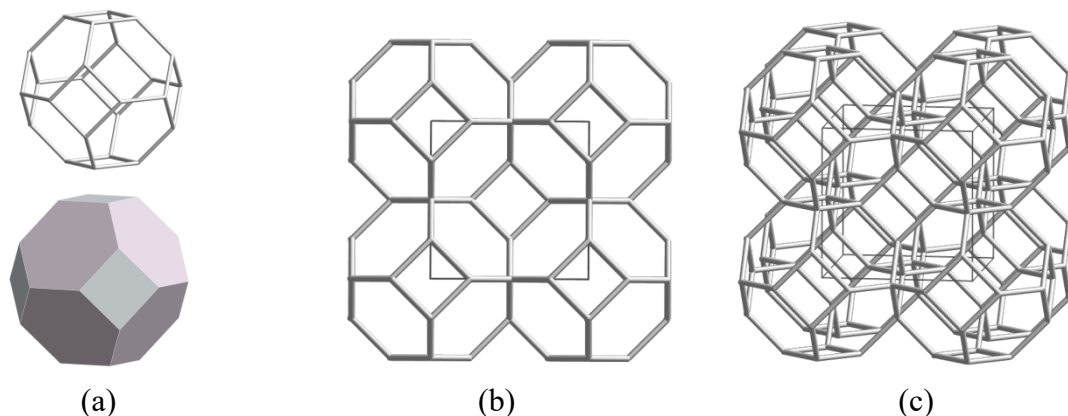

Figure 7.2 Framework structure of Sodalite Cage

(a) **SOD** cage; (b) and (c) Framework of **SOD** along different direction with the unit cell surrounded by thin solid lines.

In order to highlight the porous characteristics of zeolite, the framework structure focusing on the connectivity of T atoms is put forwards. Sodalite is a well-known zeolite with a typical chemical formula of  $\text{NaAlSiO}_4$ . Its framework structure is made up of sodalite cages. Sodalite cage, also known as  $\beta$ -cage, can be regarded as a truncated octahedron, as shown in Figure 7.2a. In the framework of sodalite, the cages are connected through common 4- and 6-rings, and then extended to three-dimensional space, forming a cubic framework as shown in Figure 7.2b and 7.2c.

**7-4-1 Write** down the composition of an isolated sodalite cage as a pure poly-silicate anion.

**7-4-2 Write** down the composition of unit cell of sodalite (its chemical formula is  $\text{NaAlSiO}_4$ ).

## Problem 8. Mars Chemistry

On May 15, 2021, China's first Mars rover 'Zhurong' landed on the Red Planet of Mars. Various studies indicated that the atmosphere of Mars is mainly composed of carbon dioxide (95.3%), nitrogen (2.7%), argon (1.6%), trace oxygen (0.15%) and water vapor (0.03%). In addition, trace methane of ppb amounts has been observed in the Martian atmosphere. Methane is usually considered as an indication of the existence of life, i.e., produced from microbes. However, an inorganic source is also possible: olivine and carbon dioxide can also produce methane after serpentinization under high temperature and high pressure.

**8-1** Up to now, no signs of life have been found on Mars, and methane gas more likely comes from inorganic sources. Mars is rich in olivine ( $\text{M}_2\text{SiO}_4$ ,  $M = \text{Fe}$  or  $\text{Mg}$ ). Iron olivine can react with the gases in Mars's atmosphere to produce silica, magnetite, and methane. **Write** the equation.

**8-2** Within two Martian years, the Mars rover detected that the methane content changed from 0.3 ppb to 0.7 ppb. **How** many grams of iron olivine does it take to make such a change of methane concentration? (Assuming that the Martian atmosphere is uniformly distributed, the average atmospheric pressure is 750 Pa, the temperature is 210 K, the thickness is about 200 km, and the diameter of Mars is 6796 km)

**8-3-1** In the surface soil of Mars, the iron content is about 18%. Therefore, iron production is an important step in the development of Mars. Besides magnetite, the common iron ores on Mars also possess a large amount of hematite. Chemical reactions can be designed to identify magnetite and hematite: Dissolve the mineral with  $\text{H}_2\text{SO}_4$ , take a small amount of the liquid to be tested, add a few drops of \_\_\_\_\_ (**write** the compound formula) solution, the purple color of the solution fades, indicating that there is \_\_\_\_\_ (**choose**  $\text{Fe}^{2+}$  or  $\text{Fe}^{3+}$ ) from the mineral of \_\_\_\_\_ (**choose** magnetite or hematite). If the solution doesn't change color, the mineral contains \_\_\_\_\_ (**choose** magnetite or hematite).

**8-3-2** One feasible pathway for iron production is the reduction of iron oxides using hydrogen as reducing agent. Besides hydrogen production from water electrolysis,  $\text{H}_2$  can also be produced from  $\text{CH}_4$ :

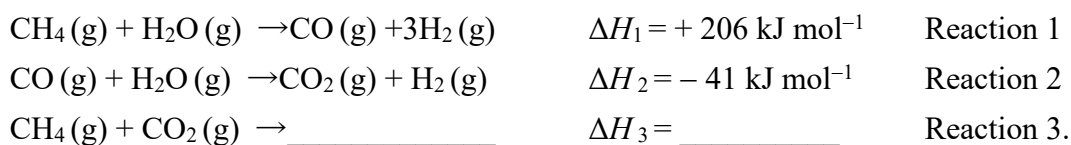

**Write** the products and  $\Delta H_3$  for reaction 3.

**8-3-3** An important application of the above reactions is to produce syngas, which can provide energy for the Mars base. For example, both  $\text{H}_2$  and  $\text{CO}$  can be applied as the feedstock for molten carbonate fuel cells. **Write** the anode-reaction equations respectively.

## Problem 9. Greenhouse Gas and Carbon Neutrality

The United Nations Assessment Report (the fifth assessment report issued by the United Nations Intergovernmental Panel on Climate Change in 2014) points out that there is a positive correlation between the cumulative emission of greenhouse gases and the increase of global average temperature. To mitigate global warming and climate change that is a common threat to human beings, a direct and effective measure is to control and reduce the concentration of greenhouse gases in the atmosphere. In recent years, worldwide efforts have been put forward to cut carbon dioxide emission. At the 75<sup>th</sup> session of the United Nations General Assembly in 2020, China proposed striving to achieve peak carbon emission before 2030 and carbon neutrality before 2060. Technological strategies for carbon neutralization include planting trees, capturing and storing carbon dioxide, expanding the use of clean power such as in electric vehicles, boosting renewable energy, and so on.

Using  $\text{CO}_2$  as a chemical raw material can increase its value by ‘turning waste into treasure’. In the industrial production of soda,  $\text{CO}_2$ ,  $\text{NH}_3$  and  $\text{NaCl}$  are raw materials. Debang Hou, a famous Chinese scientist and chemical engineer, invented the Hou’s Process that improves the Solvay Process. Figure 9.1 shows a simplified flow diagram of Hou’s Process of Soda production.

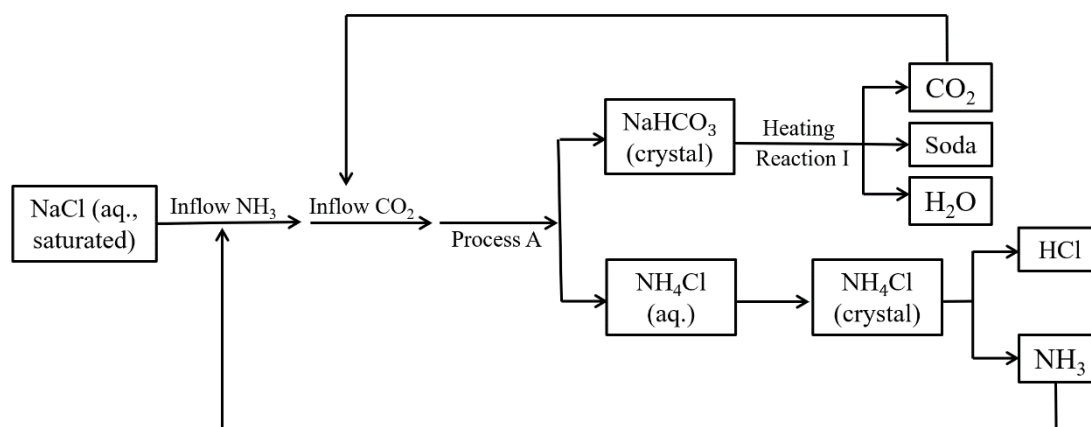

Figure 9.1 Hou's Process of Soda production

9-1-1 **Write** the equation for Reaction I

9-1-2 In the solution obtained by Process A, **compare** the molar number of ions:

$$n(\text{Na}^+) \text{ \_\_\_\_\_\_ } n(\text{Cl}^-).$$

- (a) more than            (b) less than            (c) equal to

9-1-3 Hou's process features a high utilization ratio of NaCl. The key is that the solubility of  $\text{NH}_4\text{Cl}$  is \_\_\_\_\_ that of NaCl at room temperature but the former is \_\_\_\_\_ the latter at low temperatures.

**Which** of the following words fits into the blank in the above sentence?

- (a) higher than            (b) lower than            (c) equal to

Metal-carbon dioxide batteries, which employ metal and  $\text{CO}_2$  as active materials respectively in the anode and the cathode, are attractive devices, simultaneously fixing/utilizing  $\text{CO}_2$  and generating electricity. Taking Na- $\text{CO}_2$  battery as an example, assuming that the total reaction is:  $4\text{Na} + 3\text{CO}_2 \rightarrow 2\text{Na}_2\text{CO}_3 + \text{C}$  ( $\Delta_r G_m^\ominus = -905.6 \text{ kJ mol}^{-1}$ ), the Na anode releases electrons during discharge, and the metallic Na is deposited on charging.

9-2-1 **Write** down the reaction equation for the cathode of a Na- $\text{CO}_2$  battery.

9-2-2 **Select** an appropriate solvent from the following items to prepare the electrolyte of the Na- $\text{CO}_2$  battery.

- (a) water            (b) ethanol            (c) tetraethylene glycol dimethyl ether

9-2-3 **Calculate** the standard voltage of this Na- $\text{CO}_2$  battery under standard conditions.

Under mild conditions (room temperature and ambient pressure), electrochemical reduction reaction of carbon dioxide generates high value-added chemicals and fuels ( $\text{CO}_2\text{RR}$ ). This process offers a promising route for efficient conversion and storage of intermittent electricity generated from renewable energy such as solar and wind. The  $\text{CO}_2\text{RR}$  occurs on the catalyst-containing cathode of an electrolytic cell, while oxygen is released from water decomposition in the anode. Extensive research interest has been directed to formulating compatible electrolytes and exploring efficient catalysts to enhance the rate and yield of  $\text{CO}_2$  conversion into target products.

**9-3-1** Previous studies indicate that using a weakly alkaline  $\text{KHCO}_3$  aqueous solution as the electrolyte and a Cu-based catalyst can promote the reduction of  $\text{CO}_2$  to generate ethylene. Providing only ethylene as the product from  $\text{CO}_2$ , **write** the cathode and anode reactions of the electrolytic cell.

**9-3-2** In addition to ethylene, there are gaseous products (e.g.,  $\text{H}_2$ ,  $\text{CO}$ , and  $\text{CH}_4$ ) and liquid products (e.g., formic acid and ethanol) generated in the process of  $\text{CO}_2$  reduction. Gas chromatography is often employed to quantitatively detect the distribution of gaseous products. In a  $\text{CO}_2$  reduction experiment, the electrolysis was conducted by applying a constant current of 10.0 mA for 1.00 h. The total amount of gas entering the chromatogram was 90.0 mL as determined from the flowmeter, and the volumetric concentration of detected ethylene was 0.519%. Assuming that all produced gases are ideal gases in standard conditions, **calculate** the Faraday efficiency (defined as the percentage of the actual product in theoretical value) and the rate (unit  $\text{mg h}^{-1}$ ) of ethylene generation.

Carbon dioxide is viewed as the primary greenhouse gas emitted through human activities. One of the important paths to decrease the concentration of greenhouse gas is the capture and storage of  $\text{CO}_2$ .

**9-4-1** Assuming 1 mol of  $\text{CO}_2$  (regarded as an ideal gas) expands isothermally at the temperature ( $T$ ) of 273.15 K, if the expansion process is reversible and known work ( $W$ ) is 5.23 kJ. **Calculate** the heat ( $Q$ ), change of internal energy ( $\Delta U$ ), change of enthalpy ( $\Delta H$ ), change of entropy ( $\Delta S$ ), and change of Gibbs free energy ( $\Delta G$ ) of this process.

**9-4-2**  $\text{CO}_2$  can be captured by physical sorption in porous materials. Generally, the capacity of physical adsorption \_\_\_\_\_ with increasing temperature.

**Which** of the following words fits into the blank in the above sentence?

- (a) increases                      (b) decreases                      (c) does not change

**9-4-3** Assume that the physical adsorption of  $\text{CO}_2$  on activated carbon obeys the Langmuir adsorption isotherm equation:

$$\theta = \frac{V}{V_m} = \frac{\alpha P}{1 + \alpha P}$$

where  $\theta$  is coverage of single-layer adsorbate on the surface,  $V$  is adsorbed amount in volume,  $V_m$  is saturated adsorbed amount in volume,  $\alpha$  is a constant, and  $P$  is partial pressure of adsorbate gas.

In two separate tests, the partial pressures of  $\text{CO}_2$  in the adsorption state are 5.2 kPa and 13.5 kPa at 298 K, and the corresponding equilibrium adsorption capacities measured after desorption are  $0.0692 \text{ m}^3 \text{ kg}^{-1}$  and  $0.0826 \text{ m}^3 \text{ kg}^{-1}$  (already converted to standard conditions), respectively.

**(1) Determine** the saturated adsorption capacity of the tested activated carbon;

**(2)** If the dynamic cross-sectional area of a  $\text{CO}_2$  molecule is  $0.32 \text{ nm}^2$ , **determine** the specific surface area of the tested activated carbon.

## Problem 10. Packing of binary crystals

The structures of binary crystals can be viewed as the packing of atoms of the first element, and the atoms of second element filling into the holes formed by the first one. In the unit cell of the  $\gamma$ -AgI crystal ( $a = 647.3$  pm),  $\text{I}^-$  anions are arranged in a face-centered cubic (*fcc*) manner, and  $\text{Ag}^+$  cations fill into half of the tetrahedral holes formed by the array of  $\text{I}^-$  anions.

**10-1 Label** the Ag atoms in the figure below, and **calculate** the Ag-I bond length and the density of the crystal.

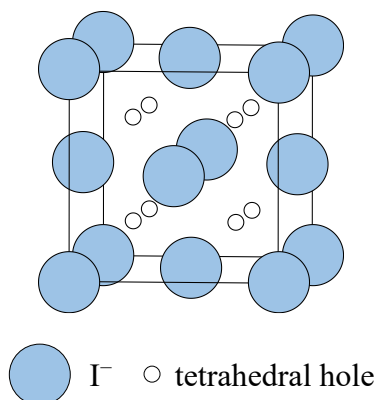

Upon changing temperature and pressure, the crystal of AgI can be transformed to the NaCl type or the CsCl type. when X-rays of wavelength ( $\lambda$ ) 154.2 pm were used, X-ray diffraction measured the glancing angles ( $\theta$ ) of the (200) reflection ( $h = 2, k = 0, l = 0$ ) of the two types of crystals to be  $14.7^\circ$  and  $21.0^\circ$ , respectively. Bragg's law:  $\sin \theta = \frac{\lambda}{2a} \sqrt{h^2 + k^2 + l^2}$

**10-2 Calculate** the unit cell dimensions  $a$  and the Ag-I bond lengths of these two types of crystals.

In the  $\alpha$ -AgI crystal ( $a = 504$  pm),  $\text{I}^-$  anions are arranged in a body-centered cubic (*bcc*) manner. The tetrahedral and octahedral holes formed by the  $\text{I}^-$  anions are presented below. Under the influence of an external electric field,  $\text{Ag}^+$  cations can move freely across the trigonal holes such as  $\triangle ABC$ . Assuming that  $\text{I}^-$  anions are in contact with each other and both  $\text{I}^-$  and  $\text{Ag}^+$  are hard spheres.

**10-3 Calculate** the radius of  $\text{I}^-$ ,  $r(\text{I}^-)$ , and the maximum radius of  $\text{Ag}^+$ ,  $r_{\max}(\text{Ag}^+)$ .

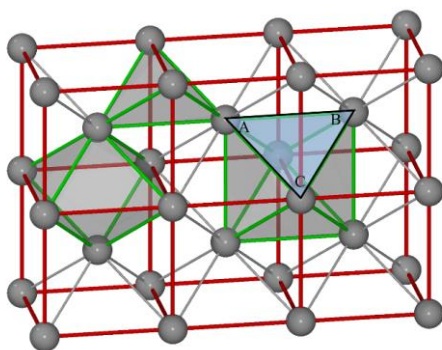



## Problem 11. Determination of Calcium Ions by Titration with Ethylene Bis(oxyethylenenitrilo) Tetraacetic Acid (EGTA)

Aminocarboxy ligands are a class of reagents with amino groups and carboxylic groups. These reagents, containing oxygen and nitrogen as coordination atoms, can bind to many metal ions to form stable chelates. The reagents are widely used in analytical chemistry and biochemistry as masking agents, separation reagents and titrants. Ethylene bis(oxyethylenenitrilo) tetraacetic acid (EGTA, H<sub>4</sub>E) is one such aminocarboxy ligand reagents. Its molecular formula is C<sub>14</sub>H<sub>24</sub>N<sub>2</sub>O<sub>10</sub>. EGTA is a hexaprotic acid when it combines two other protons. The following species can exist: H<sub>6</sub>E<sup>2+</sup>, H<sub>5</sub>E<sup>+</sup>, H<sub>4</sub>E, H<sub>3</sub>E<sup>-</sup>, H<sub>2</sub>E<sup>2-</sup>, HE<sup>3-</sup> and E<sup>4-</sup>. The first two dissociations are those of strong acids and its remaining four dissociation constants pK<sub>a3</sub>-pK<sub>a6</sub> are 2.08, 2.73, 8.93 and 9.53, respectively. EGTA can coordinate with calcium ions and magnesium ions to form chelates. The formation constants of the calcium-EGTA and magnesium-EGTA chelates are lgK<sub>CaE</sub> = 10.97, lgK<sub>MgE</sub> = 5.21, respectively.

**11-1** H<sub>4</sub>E is dissolved in 0.10 mol L<sup>-1</sup> NaOH solution to prepare EGTA solution of 0.020 mol L<sup>-1</sup>. **Why** it is not dissolved in distilled water directly?

**11-2 Calculate** the coefficient of acid effect  $\alpha_{E(H)}$  of H<sub>4</sub>E at pH10 in the buffer solution.

**11-3** Titrate 0.01000 mol L<sup>-1</sup> Ca<sup>2+</sup> in the presence of 0.01000 mol L<sup>-1</sup> Mg<sup>2+</sup> with 0.01000 mol L<sup>-1</sup> H<sub>4</sub>E at pH10 in the NH<sub>3</sub>-NH<sub>4</sub>Cl buffer solution. Using Eriochrome Black T (EBT) as indicator, Ca<sup>2+</sup> ions concentration at end-point pCa<sub>t</sub> = 3.8, **calculate** the titration error. Mg<sup>2+</sup> ions can form a colored complex with EBT, and pMg<sub>t</sub> = 5.4.

**11-4** Because of the large error in the above determination, calconcarboxylic acid should be used as indicator. Titrate 0.01000 mol L<sup>-1</sup> Ca<sup>2+</sup> in the presence of 0.01000 mol L<sup>-1</sup> Mg<sup>2+</sup> with 0.01000 mol L<sup>-1</sup> H<sub>4</sub>E at pH12 in the sodium hydroxide solution, using calconcarboxylic acid as indicator, and Ca<sup>2+</sup> concentration at end-point pCa<sub>t</sub> = 5.6, **calculate** the titration error. Known Mg(OH)<sub>2</sub>, pK<sub>sp</sub> = 10.74, and acid effect of H<sub>4</sub>E is negligible.

**11-5** Standardization of EGTA solution: A 2.4907g of primary standard calcium carbonate is dissolved in 0.1 mol L<sup>-1</sup> hydrochloric acid, and the solution diluted to 1000.00 mL in a volumetric flask. Then the 10.00 mL solution is withdrawn and diluted to 100.00 mL in another volumetric flask to obtain standard solution. A 25.00 mL aliquot standard solution is withdrawn, adding the sodium tetraborate buffer solution and calconcarboxylic acid as indicator, titrated with solution of H<sub>4</sub>E. When the color of solution from red to bright yellow to indicate the end-point, required 25.85 mL of H<sub>4</sub>E solution. **Calculate** the concentration of H<sub>4</sub>E solution. A 0.80 mL aliquot serum sample is withdrawn, adding buffer solution and indicator, titrated with 0.83 mL solution of H<sub>4</sub>E using 5 mL burette, the color of solution from red to bright yellow to indicate the end-point. The blank experiment was carried out with distilled water 10 times the volume of serum sample as the sample, it required 0.20 mL solution of H<sub>4</sub>E to reach the end-point. **Calculate** the content of calcium (mmol L<sup>-1</sup>) in the serum sample.

## Problem 12. Fast determination of Vitamin C by gold colloids

Noble metal colloids are ancient pigments with a history of over 5000 years. A typical example is the Lycurgus cup, which was fabricated in the 6th century BC and now is preserved in the British Museum. It contains various kinds of metal colloids such as gold and silver. The glass of the Lycurgus cup has a magical dichroism: under natural lighting conditions, the glass is green (as shown in the picture, left); If the light source is placed inside the cup, the cup becomes red (right). Using modern analytical methods, scientists have found that the dichroism is closely associated with the type, size, and dispersity of the colloidal nanoparticles.



Figure 11.1 The Lycurgus cup

Gold nanoparticles are typical noble metal colloids that are widely used in analytical chemistry (such as immune colloidal gold technique) owing to their ultra-high extinction coefficients, ease of synthesis, and low cost. Generally, the synthesis of colloidal golds is based on the redox reaction between chloroauric acid and reducing substances (such as vitamin C) to produce nanoparticles composed of numerous gold atoms.

**12-1** The gold colloidal solution is red. **In which** spectral region may the maximal absorption peak appear?

- (a) Ultraviolet                      (b) Visible                      (c) Infrared

**12-2** The density  $\rho$  of solid gold is  $19.3 \text{ g cm}^{-3}$ , the mass of chloroauric acid reagent (molecular weight = 394) is 41 mg, the reaction volume is 100 mL, and the absorbance of the colloid solution is 0.8. If chloroauric acid is completely converted to uniform colloid gold particles, **calculate** the number of gold atoms in colloid gold with a diameter of 10 nm, and **calculate** the extinction coefficient of the colloid gold solution.

**12-3** Plant extract contains a large number of reducing substances (such as vitamin C), which can be used for the synthesis of gold colloids. 0.20 mL of plant extract reacted with excess chloroauric acid to form colloidal gold solution with a particle size of 10 nm. The solution was diluted to 1 mL with water and the absorbance of the diluted solution was determined to be 0.3. Another 0.2 mL of the same plant extract was mixed with the same volume of a vitamin C standard solution ( $5 \mu\text{g mL}^{-1}$ ) and then reacted with excess chloroauric acid to form 10 nm sized gold colloids. The resulting solution was diluted with water to 1 mL and the absorbance of the diluted solution was determined to be 1.0. Try to **calculate** the content of vitamin C in the plant extract.

## Problem 13. Allenes

Allenenes (**1**) are powerful chemicals in organic synthesis because they can undergo a number of important transformations such as electrophilic addition, nucleophilic addition, radical addition, carbometalation, and nucleometalation. Additionally, allene moieties occur in many natural products and pharmaceuticals.

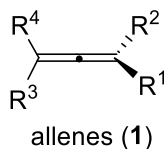

When appropriately substituted, allenenes are chiral compounds having an axis of chirality owing to the two perpendicular C=C bonds. Chirality of allenenes can be described by stereodescriptors ( $R_a$ ) and ( $S_a$ ) as shown below. When there are several kinds of substituents on the allene, the definition obeys the Cahn-Ingold-Prelog priority rule ( $a > b$ ,  $c > d$ ).

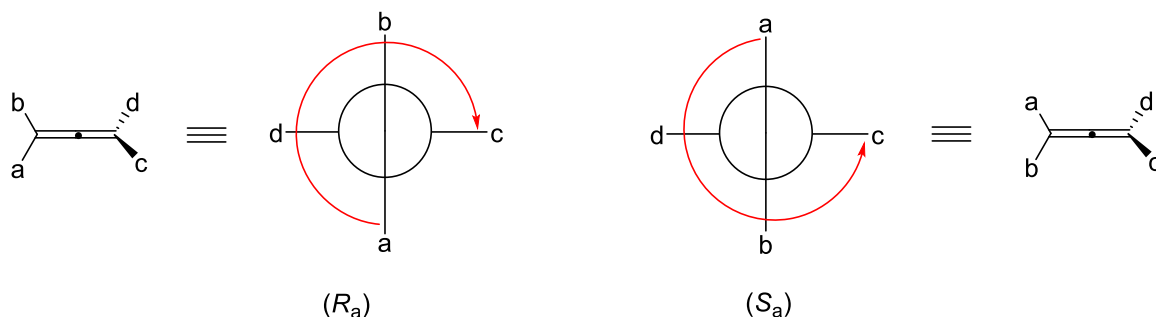

**13-1** The reaction of propargyl electrophiles with organic metal reagents is one of classical methods for the synthesis of allenenes. The propargyl electrophiles are derived from propargyl alcohols which can be readily prepared from terminal alkyne and aldehydes or ketones. Chiral allenenes can be prepared from chiral propargyl alcohols. For example, asymmetric alkynylation of isovaleraldehyde **3** with terminal alkyne **4** under the catalysis of (–)-*N*-methylephedrine/ $Zn(OTf)_2$  forms an optical pure propargyl alcohol **5**. This alcohol is converted to the mesylate and subsequently converted to (+)-**2** without loss of enantiomeric excess.

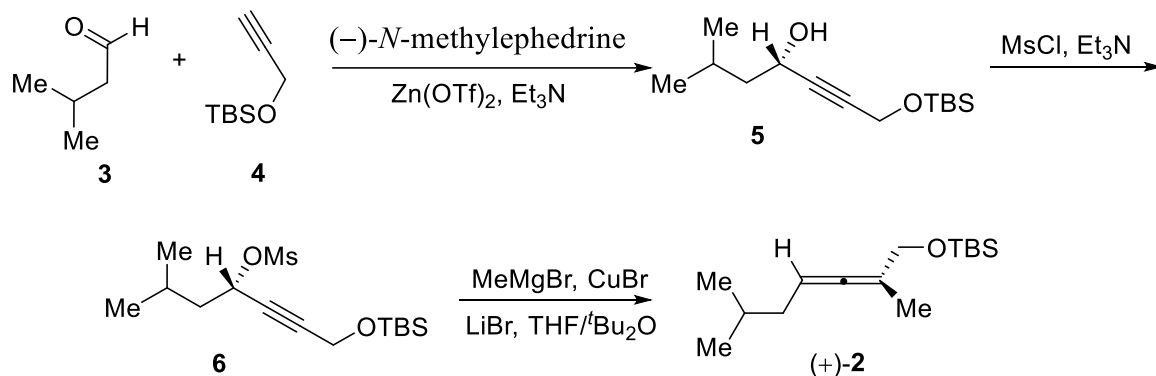

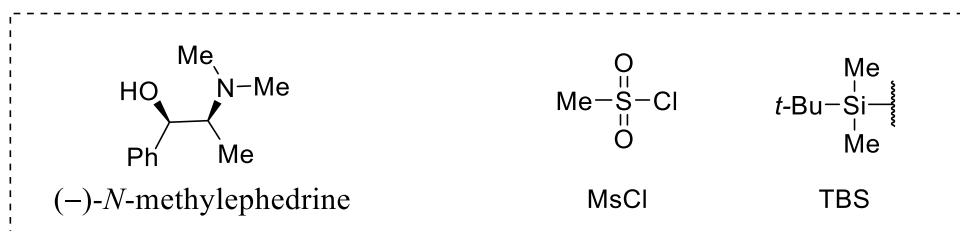

**13-1-1 Assign** the absolute configuration of (+)-**2** using the  $R_a/S_a$  nomenclature.

**13-1-2 Chose** the correct statement indicating the Grignard reagent MeMgBr used in the last step.

- (a) MeMgBr is a nucleophile.
- (b) MeMgBr is a base.
- (c) MeMgBr is an electrophile.
- (d) MeMgBr is stable in EtOH.

**13-2** The allenation of the terminal alkyne (ATA) with aldehydes or ketones in the presence of a secondary amine is a direct approach to allenes. CdI<sub>2</sub>, ZnI<sub>2</sub>, Cu(I) and Cu(II) salts are effective catalysts for this transformation. The reaction proceeds through a propargylamine intermediate *via* the nucleophilic attack of the alkynyl metal species to the iminium ion formed *in situ* from an aldehyde and amine. Imine is yielded as a by-product.

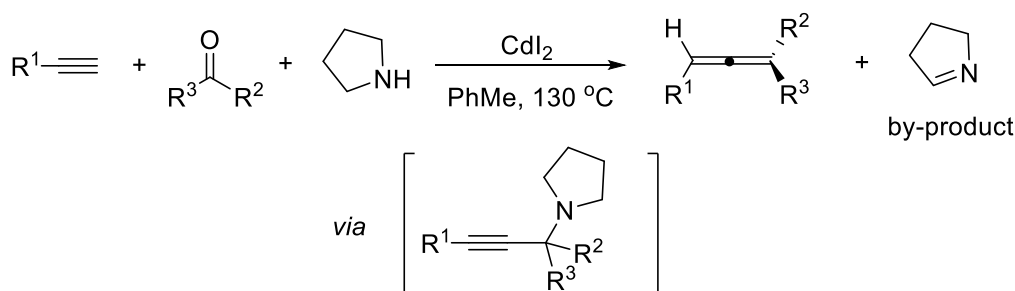

If an optical active chiral amine is used for ATA reaction, chiral allene can be generated. This reaction is known as enantioselective allenation of terminal alkyne (EATA). In the following EATE reactions, (*S*)-diphenyl-prolinol ((*S*)-**7**) delivers optical active allenoate ( $R_a$ )-**8**, while (*R*)-**7** delivers ( $S_a$ )-**8**.

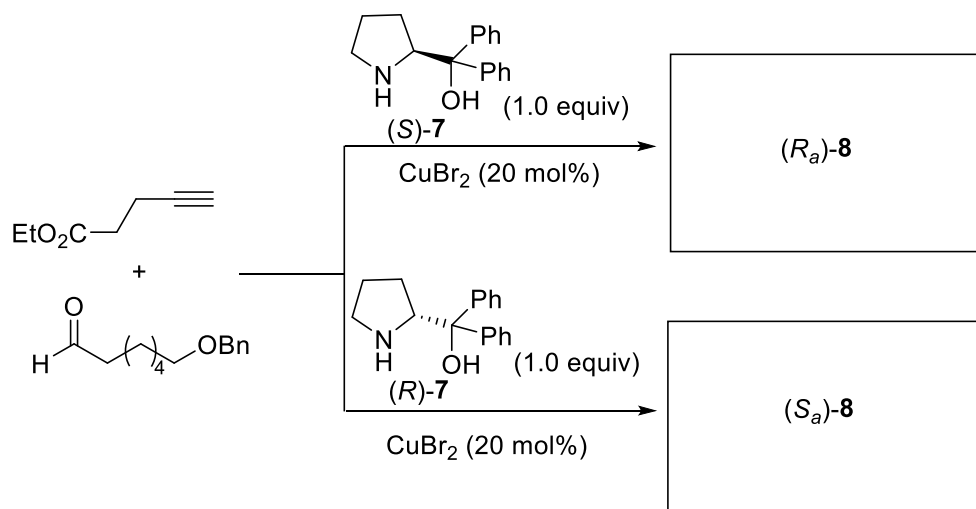

**Draw** the structures of ( $R_a$ )-**8** and ( $S_a$ )-**8**.

**13-3** Electrophilic cyclization of 2,3-allenoic acids and their esters is a powerful method for the synthesis of  $\beta$ -substituted butenolides. As shown in the following scheme, racemic 2,3-allenoate **9** reacts with  $I_2$  in MeCN/H<sub>2</sub>O to yield **10**. Treatment of **10** with LiHMDS and TIPSCl leads to the formation of intermediate **11**, which is directly subjected to silver-mediated alkylation with 2-bromomethylbut-1-ene to afford **12**. Then, hydroboration of **12** followed by oxidative workup gives **13** with a pair of inseparable diastereoisomers. However, upon oxidation of **13** into **14** using pyridinium chlorochromate (PCC), the resulting diastereoisomers **14a** and **14b** are successfully separated using column chromatography on silica gel. Upon treatment of **14b** with a catalytic amount of base such as DBU, **14a** is afforded through an epimerization of **14b** in an overall 45% yield after several cycles. Subsequently, **14a** reacts with Ph<sub>3</sub>PCH<sub>3</sub>I and LiHMDS to give **15**, which is a key intermediate for the synthesis of ( $\pm$ )-gracilioether F.

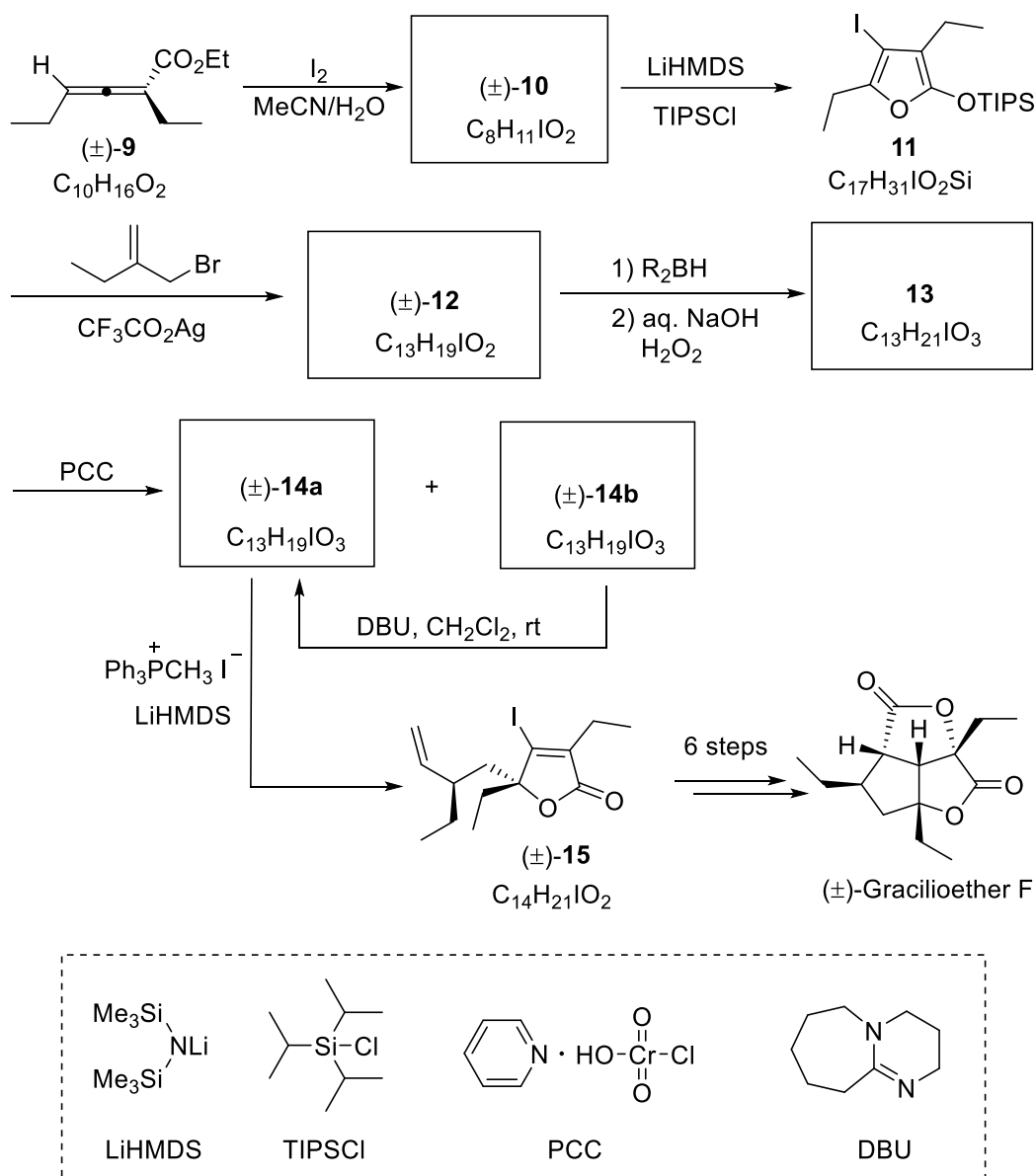

*Hint: Treating phosphonium salt with a suitable base (e.g., LiHMDS, RLi, NaH) leads to the generation of a phosphorane (phosphorous ylide), which can react with carbonyl compounds to form carbon-carbon double bonds. This type of reaction is known as the **Wittig reaction**, one of the most important and most effective method for the synthesis of alkenes.*

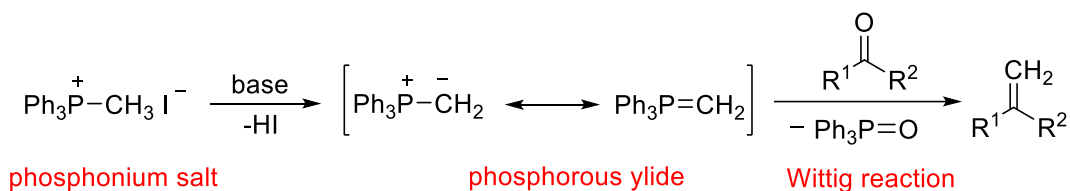

13-3-1 **Draw** the structures of compounds **10** and **12**.

13-3-2 **Draw** the structures of main reactive intermediates in the reaction of **9** with I<sub>2</sub> to afford **10**.

13-3-3 **Draw** all stereoisomers of **13** and clearly identify their stereochemistry.

13-3-4 **Draw** the structures of compounds **14a** and **14b** and clearly identify the stereochemistry for these diastereoisomers.

13-3-5 **Draw** the structure of the main intermediate in the conversion from **14b** to **14a**.

13-3-6 1,8-Diazabicyclo[5.4.0]undec-7-ene (DBU) is a strong organic base with a pK<sub>a</sub> (of the conjugate acid) of about 12.5. **Draw** the structure of conjugate acid of DBU.

13-4 The CuBr<sub>2</sub>-catalyzed EATA reaction of (*S*)-**17** with methyl 4-oxobutanoate **18** and (*R*)-**7** affords allene (*S<sub>a</sub>*,*S*)-**19**, which can be further converted into natural product (–)-xestospongiene E (**16**) in two steps.

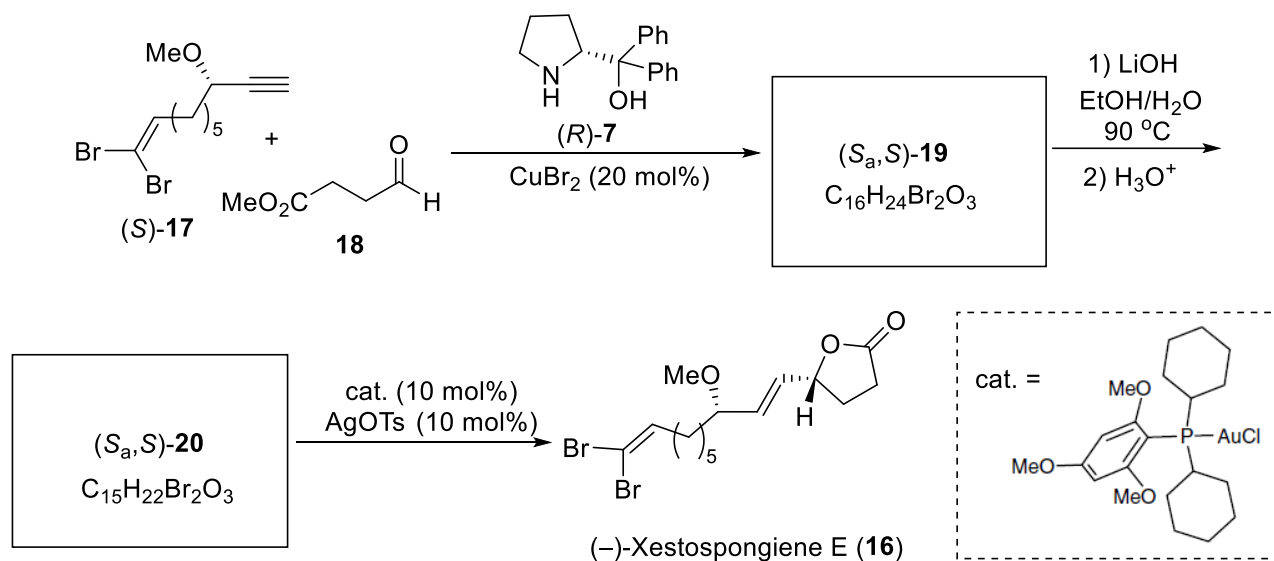

Compound (*S*)-**17** is prepared from aldehyde **21** by a route as shown below.

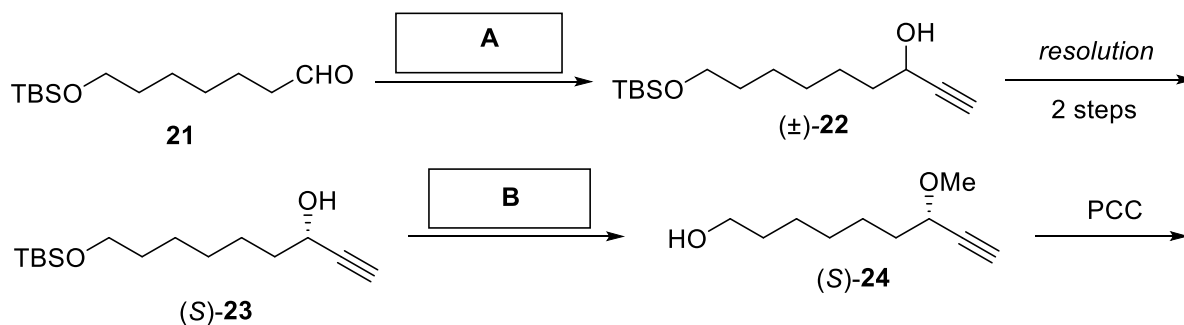

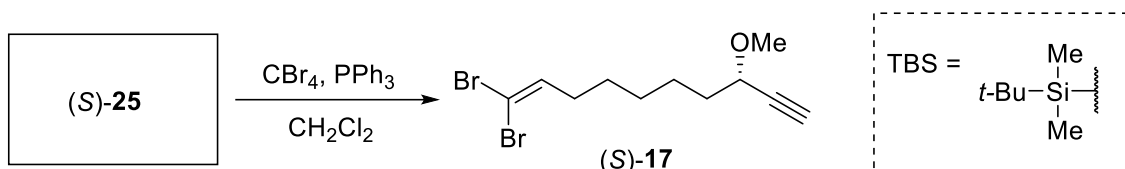

Hint:  $\text{Ph}_3\text{P}$  and  $\text{CBr}_4$  used in the conversion of **25** into **17** can generate phosphorous ylide, which undergoes Wittig-type reaction with aldehyde to afford 1,1-dibromoolefin. If the resulting dibromoolefin is further treated with 2 equivalents of *n*-butyllithium at  $-78^\circ\text{C}$  (lithium-halogen exchange and elimination), followed by simple hydrolysis, terminal alkyne can be prepared. This two-step method for alkyne synthesis is known as the *Corey-Fuchs reaction*.

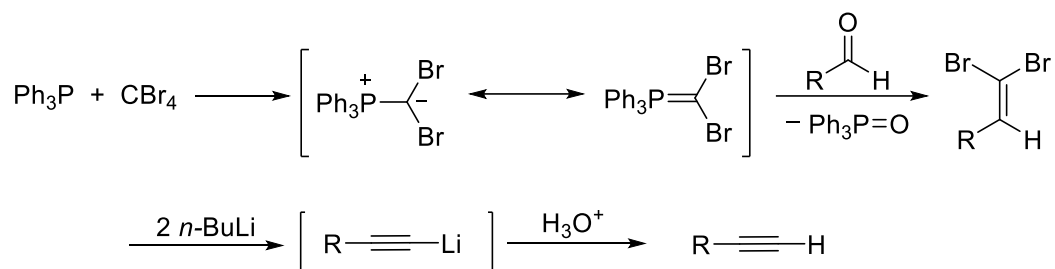

**13-4-1 Draw** the structures of chiral allenes ( $S_{a,S}$ )-**19** and ( $S_{a,S}$ )-**20** and clearly identify the stereochemistry where necessary.

**13-4-2** From the following conditions, **choose** the best for **A**

- (a) i) ethynylmagnesium bromide, THF; ii)  $\text{NH}_4\text{Cl}(\text{aq.})$
- (b) i) ethyne,  $\text{Na}_2\text{CO}_3$ ,  $\text{H}_2\text{O}$ ; ii)  $\text{NH}_4\text{Cl}(\text{aq.})$
- (c) i) ethyne,  $\text{NaH}$ , THF; ii)  $\text{NH}_4\text{Cl}(\text{aq.})$
- (d) i)  $\text{CBr}_4$ ,  $\text{PPh}_3$ ; ii)  $\text{BuLi}$ ; iii)  $\text{NH}_4\text{Cl}(\text{aq.})$

**13-4-3** From the following conditions, **choose** the best for **B**

- (a) i)  $\text{MeI}$ ; ii) 3 M  $\text{HCl}$
- (b) i)  $\text{MeONa}$ ,  $\text{MeOH}$ ; ii)  $\text{MeI}$ ; iii) 3 M  $\text{HCl}$
- (c) i)  $\text{NaH}$ , THF; ii)  $\text{MeI}$ ; iii) 3 M  $\text{HCl}$
- (d) i) 3 M  $\text{HCl}$ ; ii)  $\text{NaH}$ , THF; iii)  $\text{MeI}$

**13-4-4 Chose** the correct statement indicating the conversion of **21** into ( $\pm$ )-**22**.

- (a)  $\text{E}_2$  reaction
- (b)  $\text{S}_{\text{N}}1$  reaction
- (c)  $\text{S}_{\text{N}}2$  reaction
- (d) Nucleophilic addition

**13-4-5 Draw** the structure of ( $S$ )-**25** and clearly identify its stereochemistry.

## Problem 14. Cyclopropanes

Cyclopropane is the smallest possible saturated three membered cyclic structure. An unsubstituted cyclopropane, though highly strained, possesses enough kinetic stability with a Baeyer strain energy of  $115 \text{ kJ mol}^{-1}$  and offers limited synthetic potential. Introducing electron-accepting and electron-donating groups to cyclopropanes offers a method for increasing reactivity over their unsubstituted counterparts through C–C bond activation from the ‘push-pull’ effect, leading to the formation of 1,3-dipoles, in which the negative charge is stabilized by the acceptor while the positive charge is stabilized by the donor.

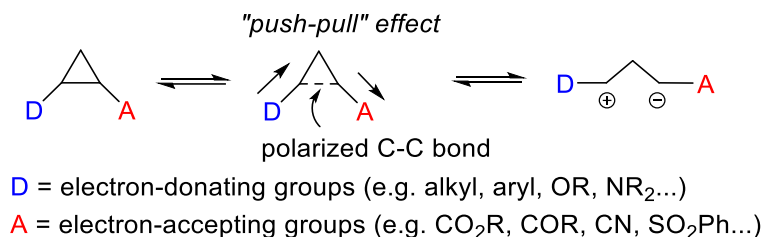

Formal cycloadditions of activated D-A (D, electron-donating group; A, electron-accepting group) cyclopropanes with a variety of electrophilic unsaturated C=C or C=X bonds are a valuable tool for accessing highly functionalized carbocyclic and heterocyclic systems. Because of the dual electrostatic character of the intermediate 1,3-zwitterion, the cyclization can begin with either an electrophilic or nucleophilic reaction with the intermediate 1,3-dipole. Very high regioselectivity is observed in all these reactions, as the partially negatively charged center of the reaction partner preferentially attacks the donor-substituted carbon atom of the three-membered ring. Ring opening is usually triggered by a LUMO-lowering Lewis acid catalyst through coordination of the electron-withdrawing substituent, very often via chelation to a diester, facilitating the attack by a nucleophile.

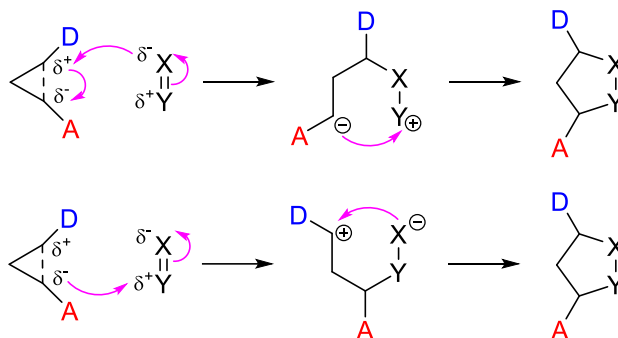

The benefits of intramolecularity for ring-opening cyclization reactions of cyclopropanes include increased reactivity, milder reaction conditions, better control of diastereoselectivity, and rapid formation of polycyclic structures. In the case that the 1,2-dipole (X = Y) is connected to C-2 of cyclopropane, depending on the regioselectivity initiated by the difference of polarities of the internal and external atoms in the 1,2-dipole, the intramolecular [3+2] formal cycloadditions can be classified into two types: ‘Intramolecular Cross-Cycloaddition (IMCC)’ and ‘Intramolecular Parallel-Cycloaddition (IMPC)’.



Intramolecular Parallel-Cycloaddition (IMPC)

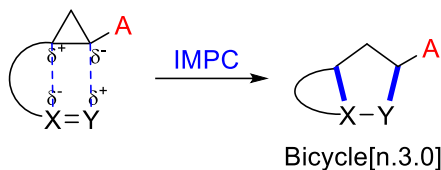

Intramolecular Cross-Cycloaddition (IMCC)

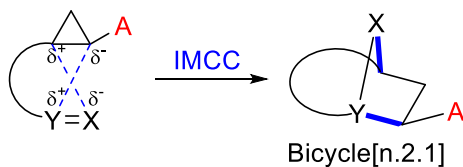

**14-1** The heats of combustion of cyclopropane and cyclohexane are 697.1 and 658.6 kJ mol<sup>-1</sup> per CH<sub>2</sub> unit, respectively. Which one is more thermally stable? Please give a choice based on the structural analysis of cyclopropane and cyclohexane, **which** of the following factors is **not** associated with this difference in thermal stability?

- (a) Hydrogen bond (b) Angle strain  
(c) Torsional strain (d) Van der Waal's force

**14-2** Substituted cyclopropanes can be obtained by the reaction of alkenes with a sulfur ylide. For example, D-A cyclopropane **1** can be prepared by the following reaction:

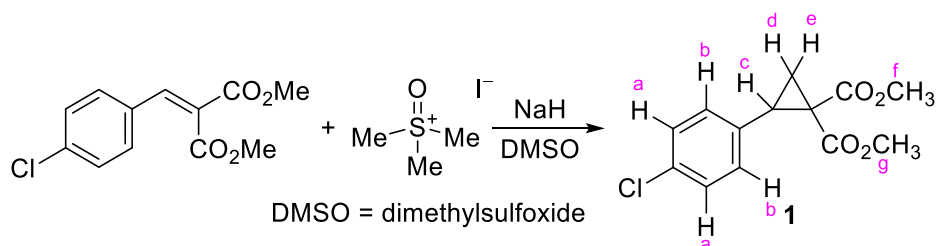

**14-2-1** **Draw** the structures of two key intermediates **A** and **B** of this reaction.

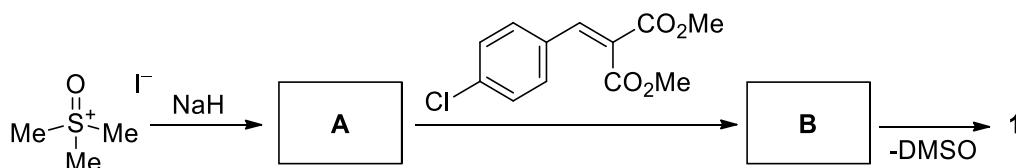

**14-2-2** The <sup>1</sup>H NMR data of **1** are showed as following: <sup>1</sup>H NMR (400 MHz, CDCl<sub>3</sub>) δ 7.23 (2H, d, *J* = 8.0 Hz), 7.19 (2H, d, *J* = 8.0 Hz), 3.77 (3H, s), 3.39 (3H, s), 3.14 (1H, dd, *J* = 9.0 and 8.1 Hz), 2.12 (1H, dd, *J* = 8.1, 5.1 Hz), 1.74 (1H, dd, *J* = 9.0, 5.1 Hz). Please assign all the peaks to the corresponding hydrogen atoms.

**14-3** The formal cycloaddition reactions of D-A cyclopropanes with unsaturated bonds are highly regioselective. **Draw** the structures of products **2-6** for the following reactions (The stereochemistry is ignored).

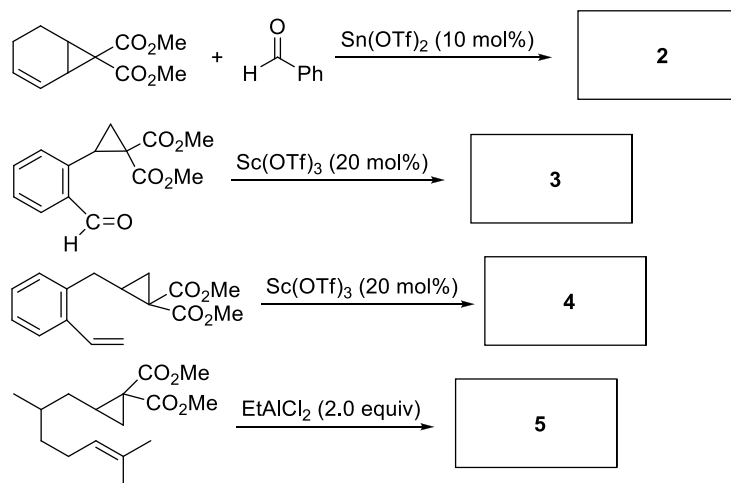

**14-4** The intramolecular cycloaddition reaction of D-A cyclopropane **6** can be promoted by Lewis acid  $\text{Yb}(\text{OTf})_3$ , to form the parallel-cycloaddition (IMPC) product **7** and cross-cycloaddition (IMCC) product **7'**. **Draw** the structures of the two possible intermediates **C** and **C'**.

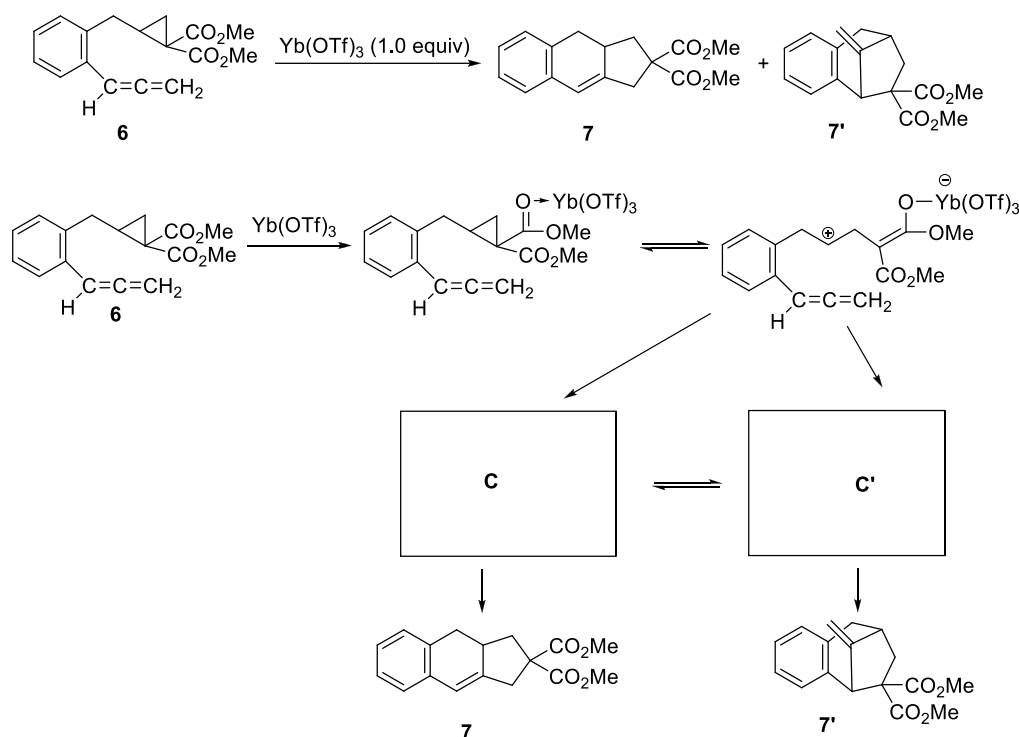

**14-5** Platensimycin is discovered in 2006 as a metabolite of *Streptomyces platensis*, and acts by efficiently blocking bacterial fatty acid biosynthesis. Because platensimycin has a unique mode of action, no cross-resistances to existing drugs have been observed to date, and no toxic effects have been detected, it has been hailed as a true breakthrough in antibiotic research. This natural product has a unique structure characterized by a 8-oxabicyclo[3.2.1]octane core. With the interesting structural features and potential biological activities, the synthesis of platensimycin began to attract attention from the synthetic community. Lewis acid-catalyzed intramolecular [3+2] cycloaddition of cyclopropane 1,1-diester with carbonyls provided an efficient construction of bridged oxa-[n.2.1] skeletons, and successfully applied it to the formal total synthesis of platensimycin. **Draw** the structures of compounds **8-12**.

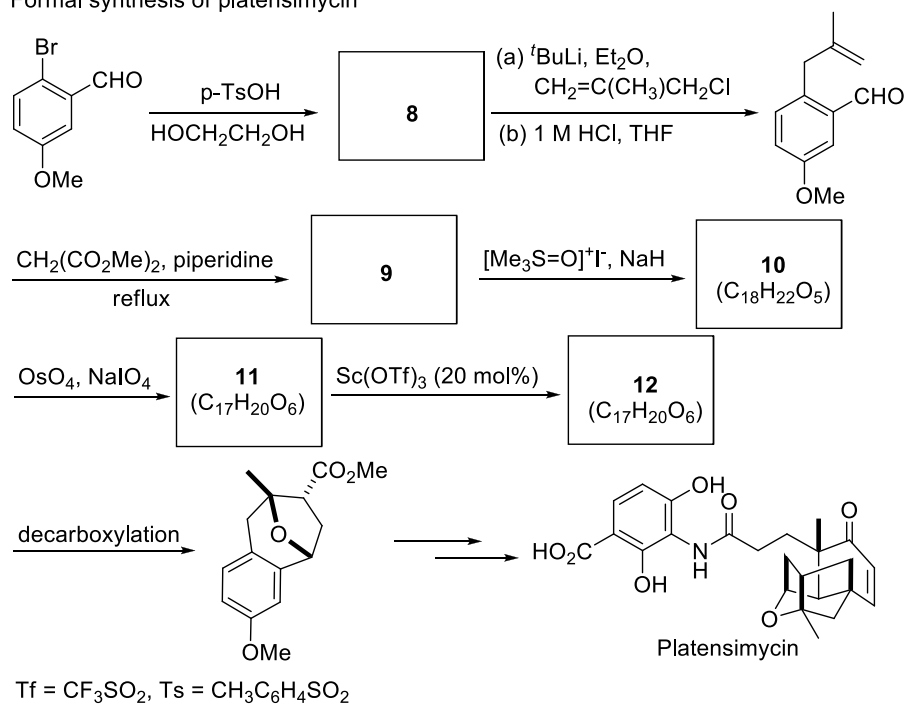

Formal synthesis of platensimycin



## Problem 15. Lewis base catalysis

The Lewis acid-base theory is one of the most fundamental theories in the chemistry. By the theory, acid is defined as species that can accept electron pair in its vacant orbital; while base is the species that can donate electron pair. Lewis base generally donates a pair of electrons, either unshared or in a  $\pi$  orbital.

**15-1** According to the Lewis acid-base theory, **choose** all the Lewis bases from the listed species below.

- (a)  $\text{AlCl}_3$       (b)       (c)  $\text{Br}^\ominus$       (d)       (e)  $\text{BF}_3$

By accepting electron pair from substrates, Lewis acids can act as effective catalysts in such important reactions as the Friedel-Crafts reaction, the  $\text{S}_{\text{N}}1$  substitution reaction and the Diels-Alder reaction. In contrast, by donating electron pair to form covalent bonding interactions with substrates, Lewis bases also can effectively catalyze many reactions.

Early in 1963, Rauhut and Currier reported a tertiary phosphine Lewis base-catalyzed dimerization of acrylonitrile or acrylate in a patent application. Afterwards, this reaction is called Rauhut-Currier (RC) reaction that takes place in an alcoholic solvent. Its plausible mechanism consists of the following four steps: Initially, tertiary phosphine engages in nucleophilic attack at electron-deficient alkene, producing zwitterionic intermediate **A** (step 1); intermediate **A** subsequently reacts with another substrate molecule to generate intermediate **B** (step 2); intermediate **B** undergoes proton transfers under the aid of protic alcoholic solvent to produce intermediate **C** (step 3); finally, intermediate **C** decomposes, releasing product dimer and catalyst phosphine (step 4).

### Rauhut-Currier reaction

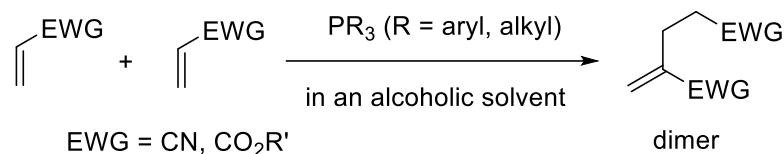

### Proposed mechanism:

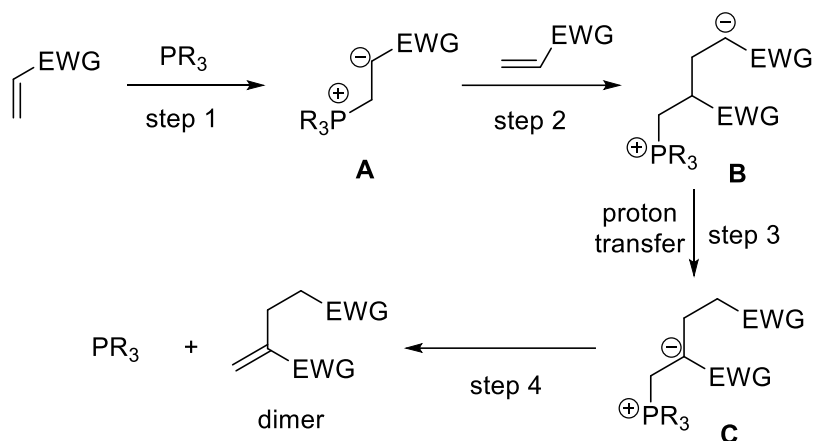

**15-2 Choose** the listed terms to describe the transformations of step 2 and step 4.

- (a) condensation; substitution
- (b) conjugate addition; substitution
- (c) conjugate addition; elimination
- (d) condensation; elimination

As illustrated above, an RC product from a single electron-deficient alkene is called homo-coupling product; from two different electron-deficient alkenes is thus cross-coupling product, which possesses more uses in organic synthesis. However, since structurally similar alkene substrates possess similar reactivity under the catalysis of Lewis bases, developing highly selective intermolecular RC reaction faces more challenges.

**15-3 Give out** All the RC products of the reaction below.

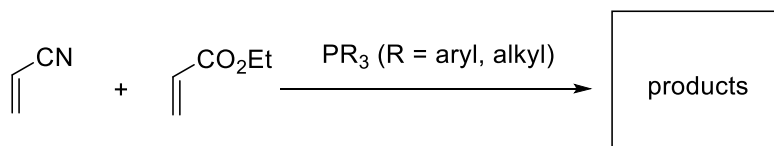

Krische and Roush et al. first developed intramolecular RC reactions, which effectively achieve highly selective cross-couplings of different electron-deficient alkenes and meanwhile provide effective synthetic methods for five- and six-membered cycles.

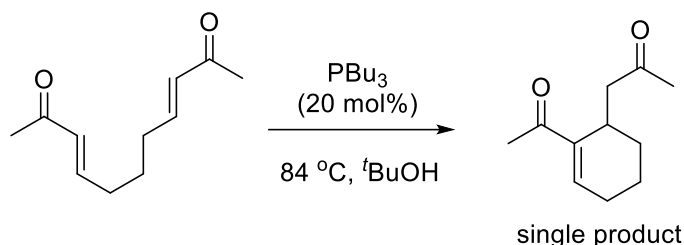
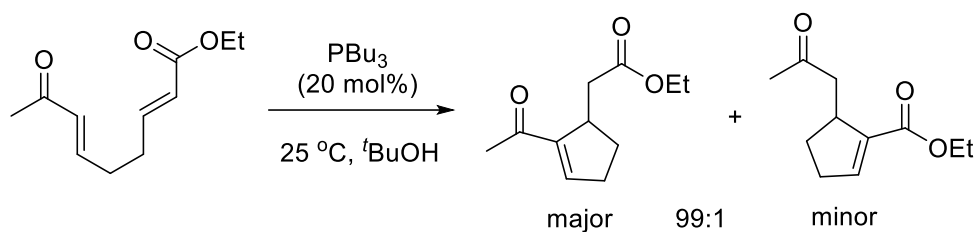

**15-4** When chiral compound **D** bearing three chiral centers was treated under similar conditions, two products **E** and **F** with a ratio of 95:5 were obtained. It was known that the cyclization of the reaction proceeded via a six-membered chair-like transition state similar to the schematic **TS** for the major product **E**. Draw the structures of **E** and **F** with correct stereochemistry.

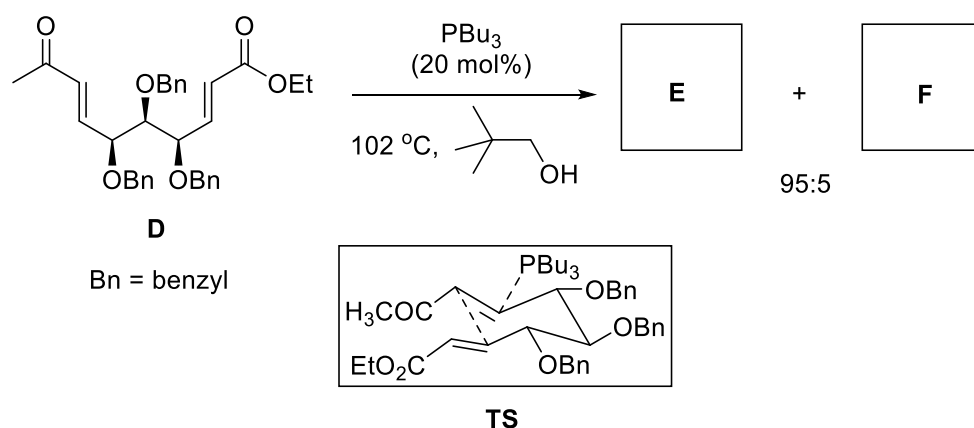

Morita-Baylis-Hillman (MBH) reaction is another famous organic Lewis base-catalyzed carbon-carbon bond forming reaction. Under the catalysis of a Lewis base, aldehydes or some specific ketones undergo addition with electron-deficient alkenes, producing allylic alcohols. Such allylic alcohols and their derivatives are versatile in organic synthesis. In this reaction, effective catalysts include tertiary amines and tertiary phosphines. For example, the MBH reaction between aldehydes and electron-deficient alkenes may be illustrated below.

#### Morita-Baylis-Hillman Reaction

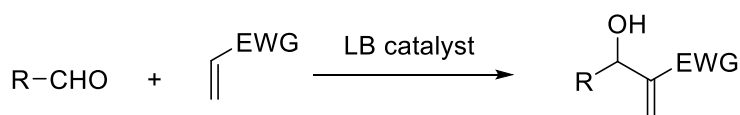

R = alkyl, aryl, etc.

EWG = CO<sub>2</sub>R', COR', CN, etc.

LB = *tertiary* amines, phosphines

**15-5** As shown below, a Lewis base DABCO-catalyzed MBH reaction of chiral aldehyde (*S*)-**G** and ethyl acrylate delivers two stereoisomers **H** and **I**. Under the aid of Ru catalyst, the minor product **I**

engages in an intramolecular metathesis to yield tetrahydropyridine **J**. Upon treatment with OsO<sub>4</sub>, compound **J** undergoes stereoselective dihydroxylation to give hexahydropyridine derivative **K**. In the dihydroxylation reaction, the stereoselectivity is controlled by the hydroxy group of the substrate **J**; Under the similar conditions, the major product **H** can also be similarly transformed into the corresponding tetrahydropyridine **L** and hexahydropyridine **M** in high yields. The Ru-catalyzed intramolecular metathesis of compound **I** or **H** proceeds similarly as octa-1,7-diene does. **Draw** the structures of **H**, **I**, **L** and **M** with accurate stereochemistry (referring to compounds **J** and **K**).

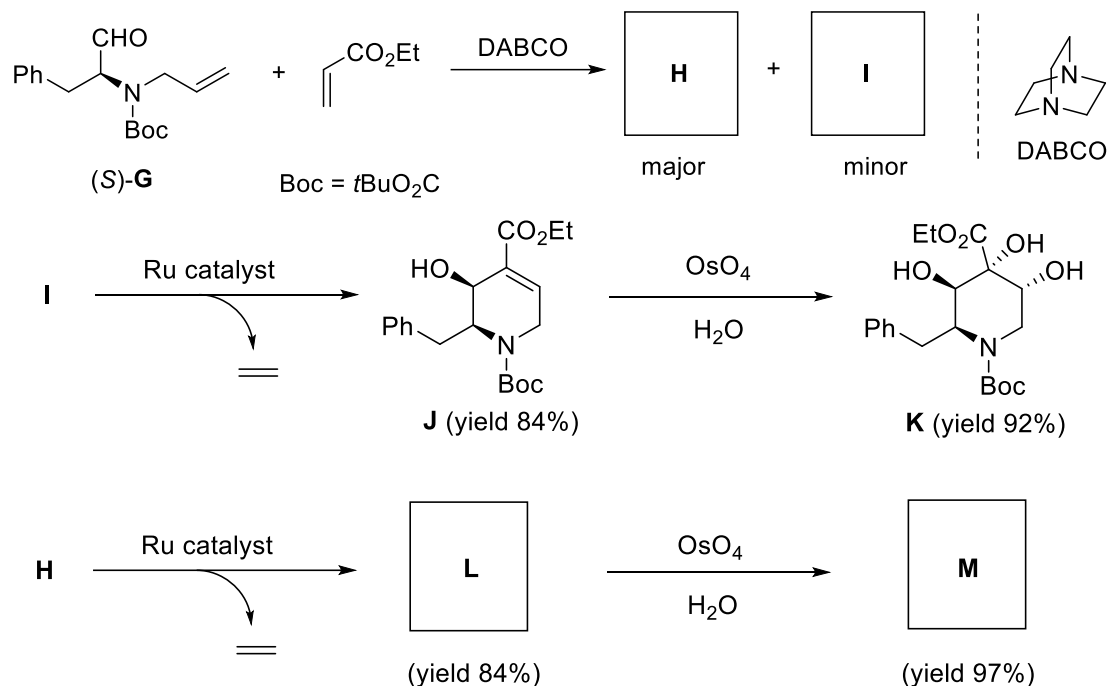

A schematic intramolecular methathesis:

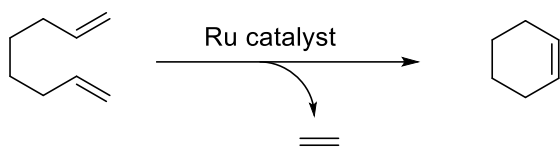

**15-6** Regarding the relationship between compounds **H** and **I** and that of compounds **K** and **M**, choose the following correct descriptions.

- Compounds **I** and **H** are a pair of enantiomers.
- Compounds **I** and **H** are a pair of epimers.
- Compounds **K** and **M** are a pair of enantiomers.
- Compounds **K** and **M** are a pair of epimers.
- Compounds **K** and **M** are a pair of diastereomers.

Derivatives of MBH products are useful substrates in the Lewis base-catalyzed cyclization reactions. For example, MBH product **N**, made from acetaldehyde and ethyl acrylate, can be readily transformed into its acetylated derivative **O**. Under the catalysis of triphenylphosphine, compound **O** engages in a (3+2) annulation reaction with *N*-phenyl maleimide to produce bicyclic compound **P**; interestingly, under the catalysis of DABCO, a (4+2) annulation reaction takes place instead, yielding another bicyclic compound **Q**.

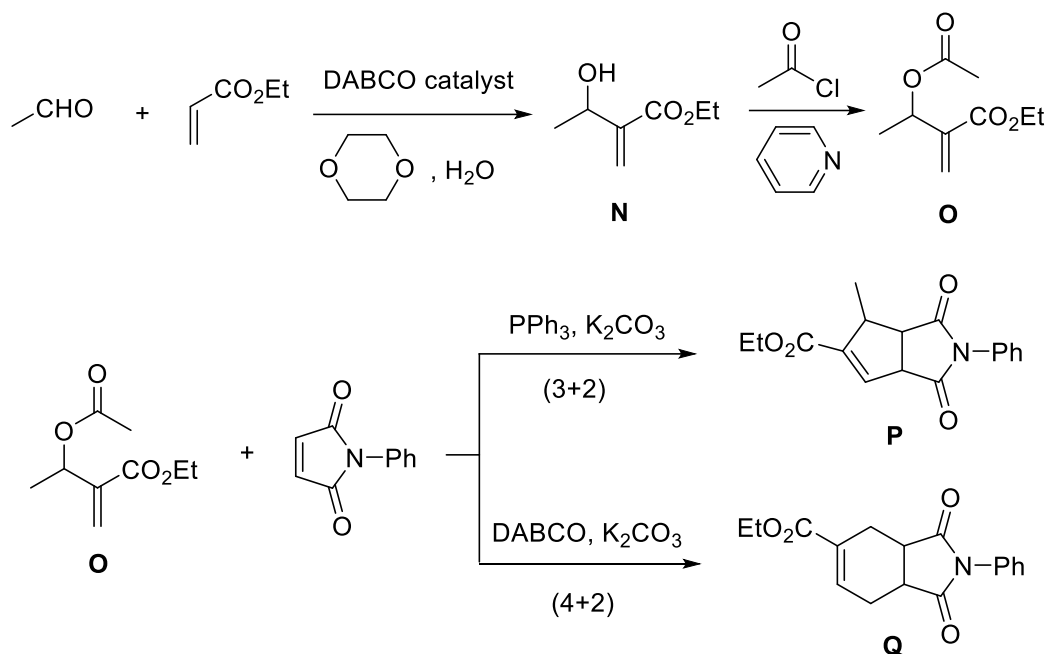

**15-7** Under the catalysis of DABCO, a similar (4+2) annulation reaction of compound **O** and dimethyl azodicarboxylate **R** takes place, giving product **S**. Draw the structure of compound **S**.

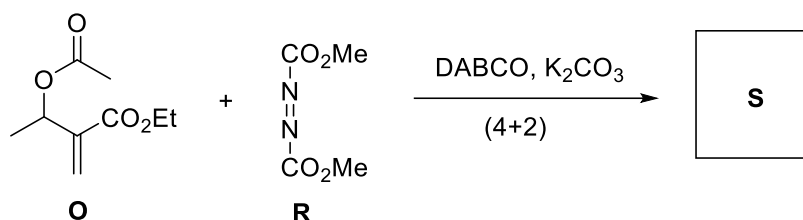

**15-8** When compound **O** reacts with excessive naphthoquinone under the catalysis of DABCO, a substituted anthraquinone **T** is obtained. Considering the oxidative ability of naphthoquinone, it is plausible that anthraquinone is formed by further oxidation of a (4+2) annulation product **U**. Under the same conditions, a similar reaction occurs between compound **O** and excessive 6-methyl naphthoquinone **V**. Draw the structure(s) of product(s) **W** and its possible isomer.

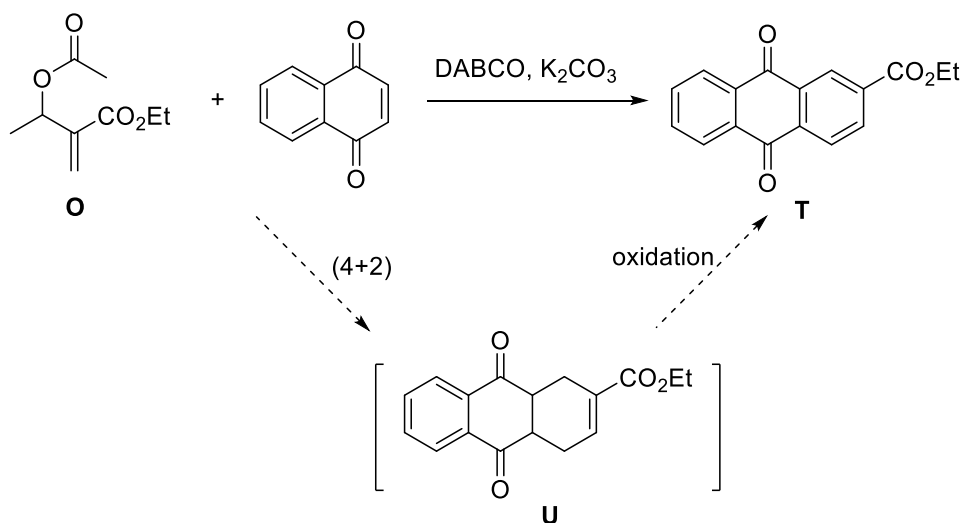

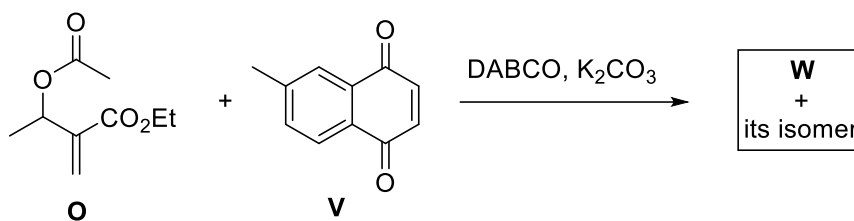

## Problem 16. Isosorbitol

In recent years, with the rising price of crude oil and the depletion of non renewable resources, the research on renewable resources - biomass and its derivatives has attracted more and more attention. Sorbitol **2**, the hydrogenation product of glucose, has become an important biomass conversion platform compound. As shown in the figure below, chiral compound **3** is produced by intramolecular dehydration of sorbitol **2**. Compound **7**, a drug for the treatment of angina pectoris, is produced by multi-step transformation.

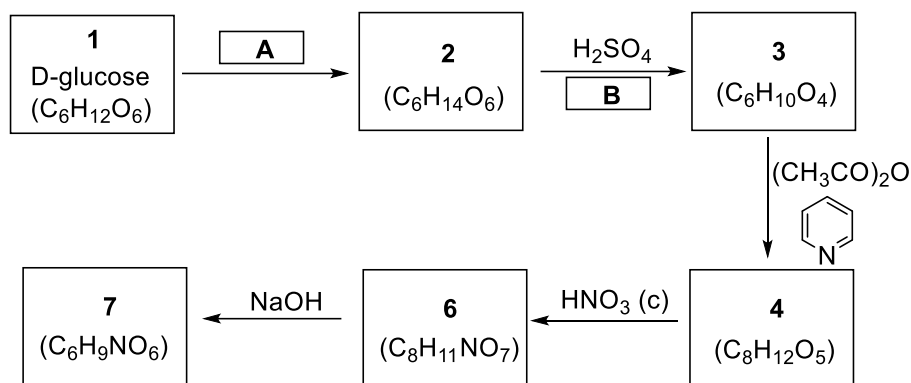

**16-1** Draw the structure of sorbitol **2** (Fisher projection)

**16-2** From the following conditions, choose the best for **A**

- (a)  $\text{Al}(\text{O}i\text{-Pr})_3$ , *i*-PrOH    (b) Pd-C, H<sub>2</sub>    (c) Na, NH<sub>3</sub>(l)

**16-3** Theoretically, compound **3** can be transformed into diastereomers **4** and **5** in the presence of acetic anhydride and pyridine. In practice, the main product is compound **4**. Draw the structures of compounds **3**, **4** and **5**. *Hint: compound 3 is a bicyclic compound.*

**16-4** To explain the reason for the selective formation of compound **4** from compound **3**, **Choose** the most appropriate option from the following reasons

- (a) Electronic effect    (b) Steric effect    (c) Field effect

**16-5** Choose the correct answer for **B** from the following options

- (a)  $-\text{H}_2\text{O}$     (b)  $-2\text{H}_2\text{O}$     (c)  $-3\text{H}_2\text{O}$

**16-6** Draw the structures of compounds **6** and **7**.



## Problem 17. Total Synthesis of Hopeanol

Among polyphenol-based natural products, resveratrol is one of the most widely distributed, having been isolated thus far from no fewer than 72 different plants, including grapevines from North America, Africa, and Europe, and various *Dipterocarpaceae* species in Southeast Asia and China. Resveratrol possesses high chemical reactivity, a property that enables its conversion into hundreds of architecturally diverse bioactive oligomeric natural products. Herein, a total synthesis route of the resveratrol-derived polyphenol natural products Hopeanol is described.

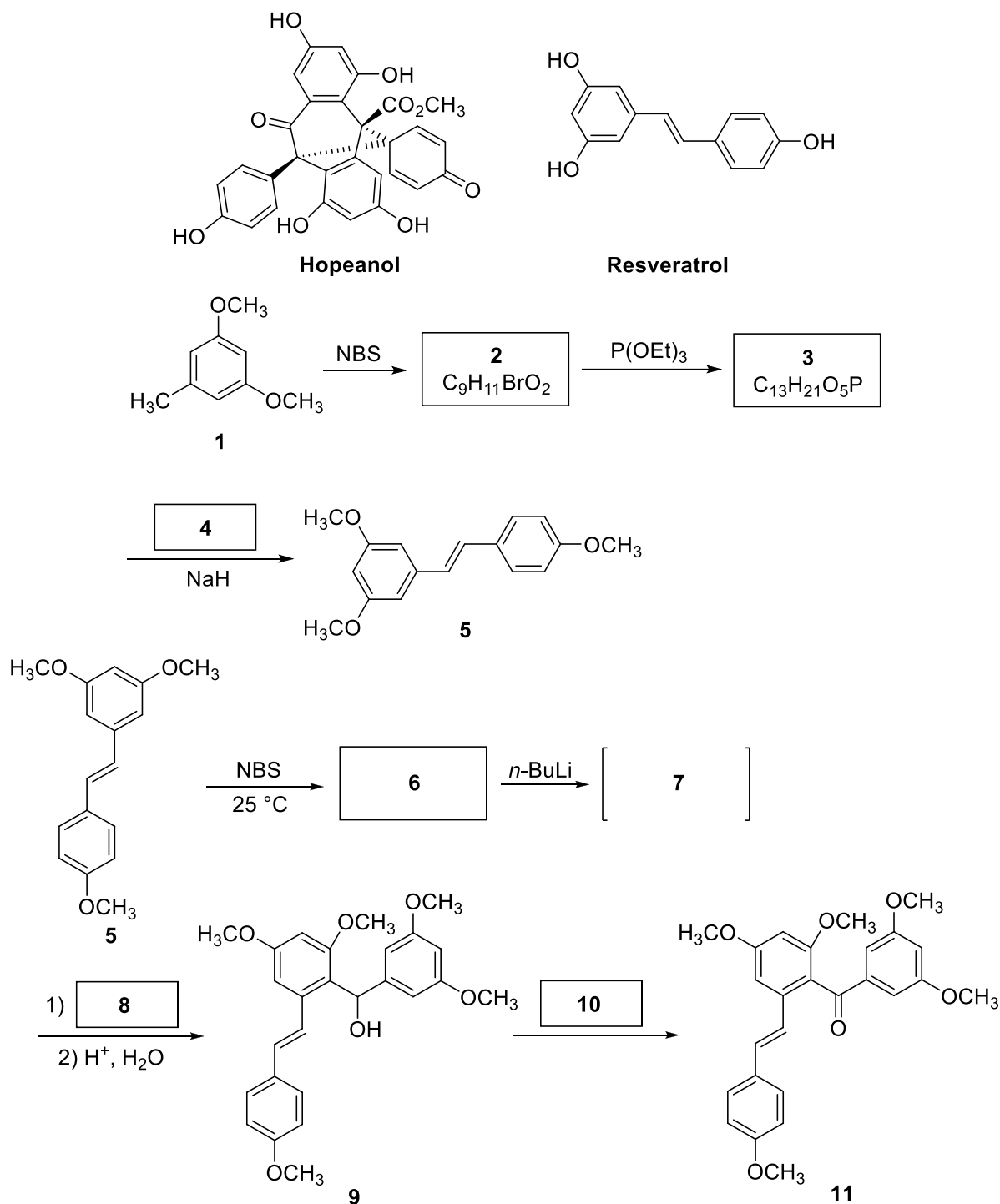

17-1 **Draw** the structures of **2** and **3**.

17-2 **Draw** the structure of **4**.

17-3 **Draw** the structures of 6 and 7.

17-4 **Draw** the structure of 8.

17-5 From the following conditions, **choose** the correct condition for 10.

- (a)  $\text{KMnO}_4, \text{H}_2\text{SO}_4$
- (b) Dess-Martin periodinane (1,1,1-Triacetoxy-1,1-dihydro-1,2-benziodoxol-3(1H)-one)
- (c)  $\text{Ag}(\text{NH}_3)_2\text{OH}$
- (d)  $\text{OsO}_4$

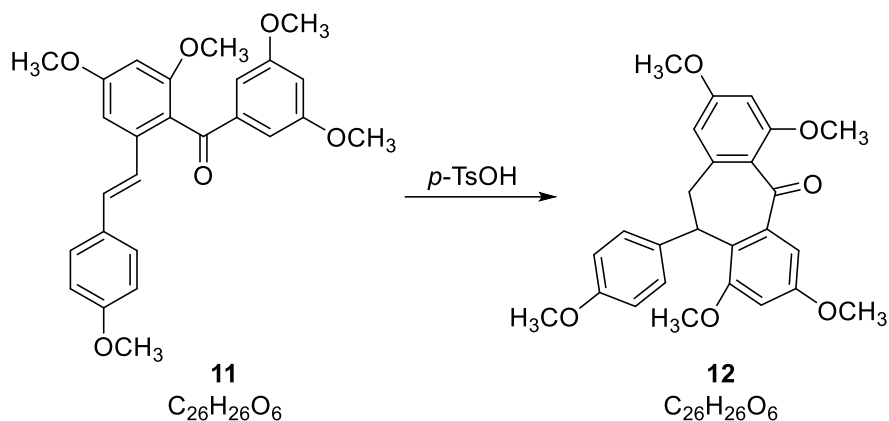

17-6 **Choose** the correct structure of intermediate for the preparation from 11 to 12.

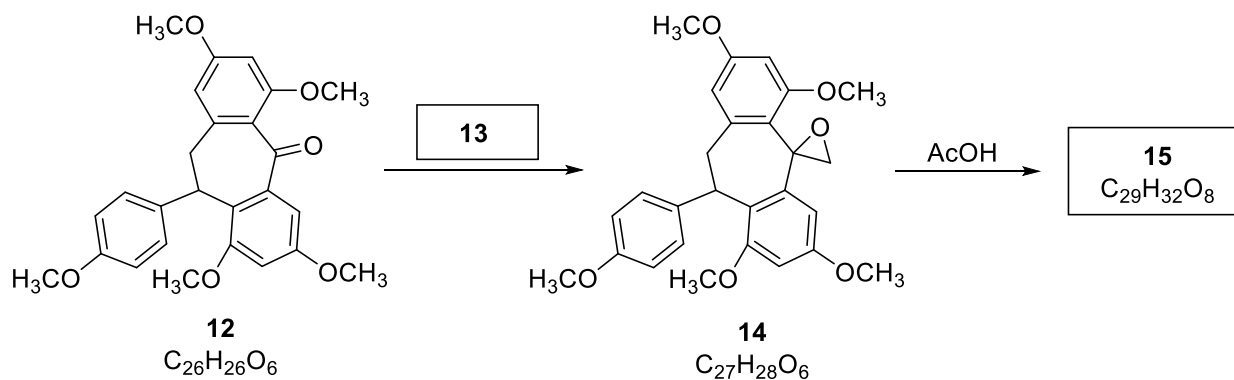
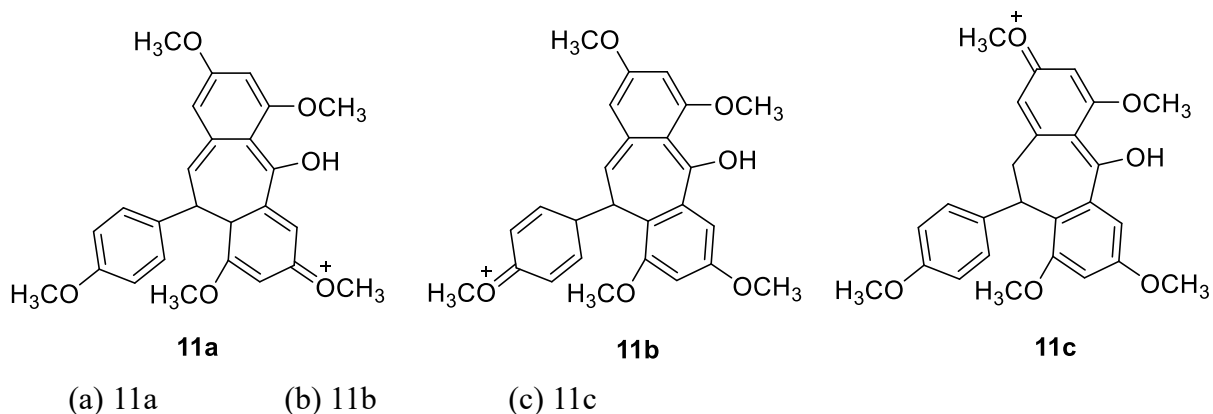

17-7 From the following conditions, **choose** the correct condition for 13.

- (a)  $\text{CH}_2\text{I}_2, \text{Zn-Cu}$
- (b)  $\text{Ph}_3\text{P}=\text{CH}_2$
- (c)  $\text{Me}_2\text{S}=\text{CH}_2$
- (d)  $(\text{CH}_3)_2\text{SO}_4$

17-8 **Draw** the structure of 15.

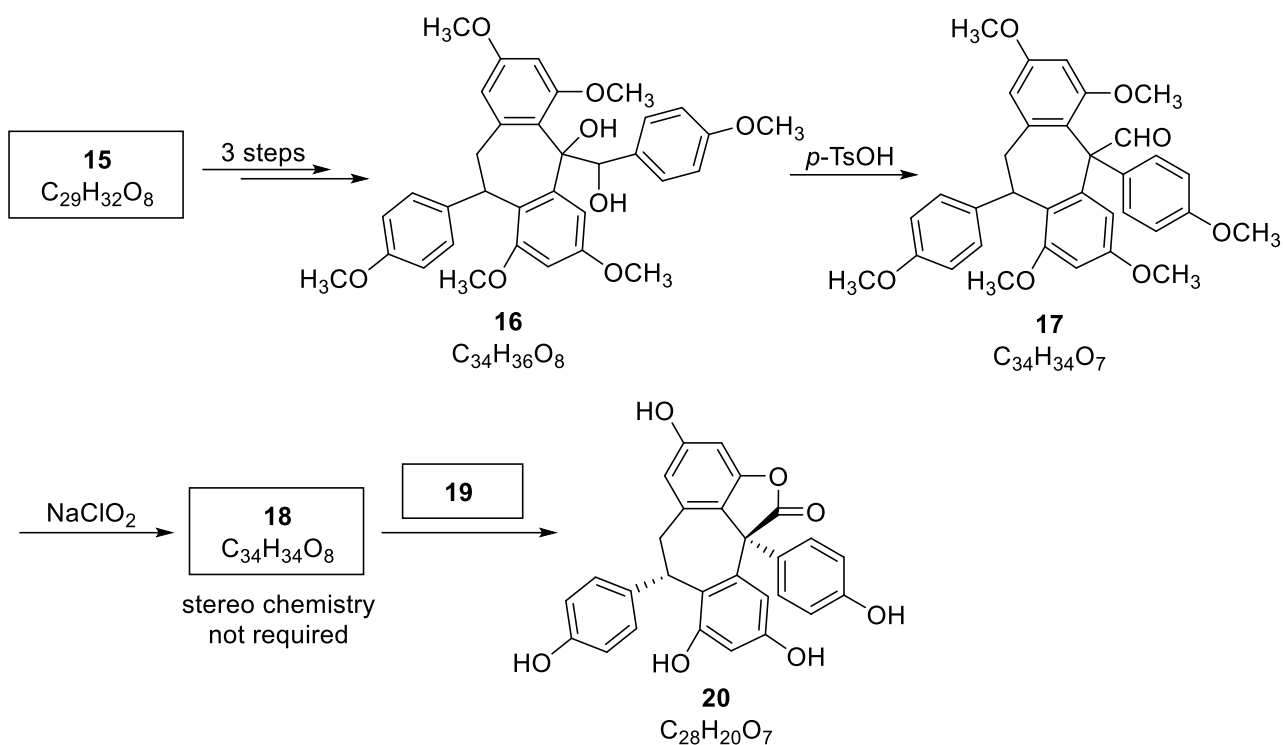

17-9 **Draw** the structure of **18**.

17-10 From the following conditions, **choose** the correct condition for **19**.

- (a)  $BBr_3$ ,  $CH_2Cl_2$       (b)  $H_2$ , Pd  
 (c)  $NaOH$ ,  $H_2O$       (d)  $H^+$ ,  $H_2O$

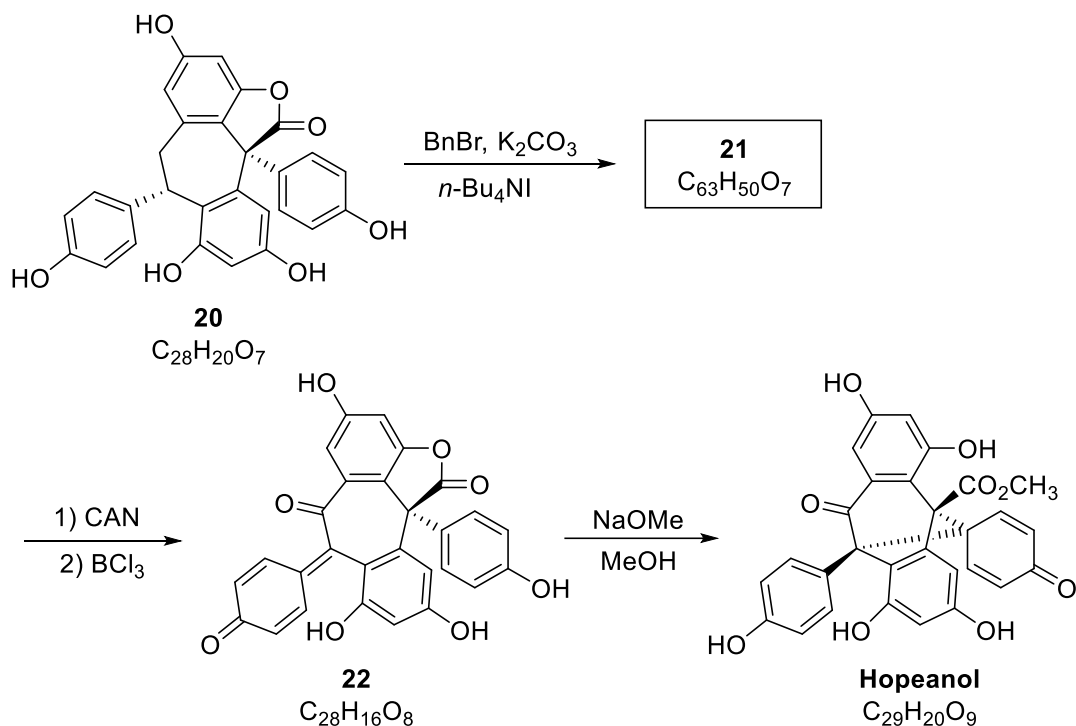

17-11 **Draw** the structure of **21**.

17-12 **Choose** the correct role of CAN (Ceric ammonium nitrate) for the preparation from **21** to **22**.

- (a) oxidant      (b) reductant      (c) Lewis catalyst      (d) deprotection reagent

## Problem 18. Total Synthesis of Lithospermic acid

Lithospermic acid was first isolated from the root of *Lithospermum ruderale* in 1963 by Johnson and co-workers. Lithospermic acid is an active ingredient of the Chinese herb *Danshen* and shows important biological properties. Herein, a total synthesis route of Lithospermic acid is described.

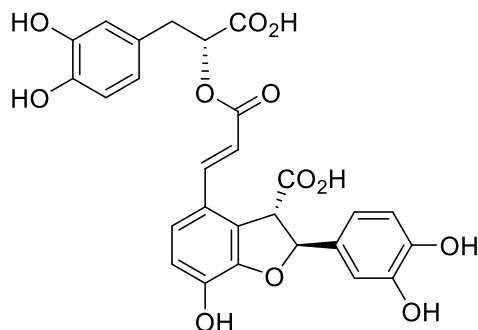

(+)-Lithospermic acid

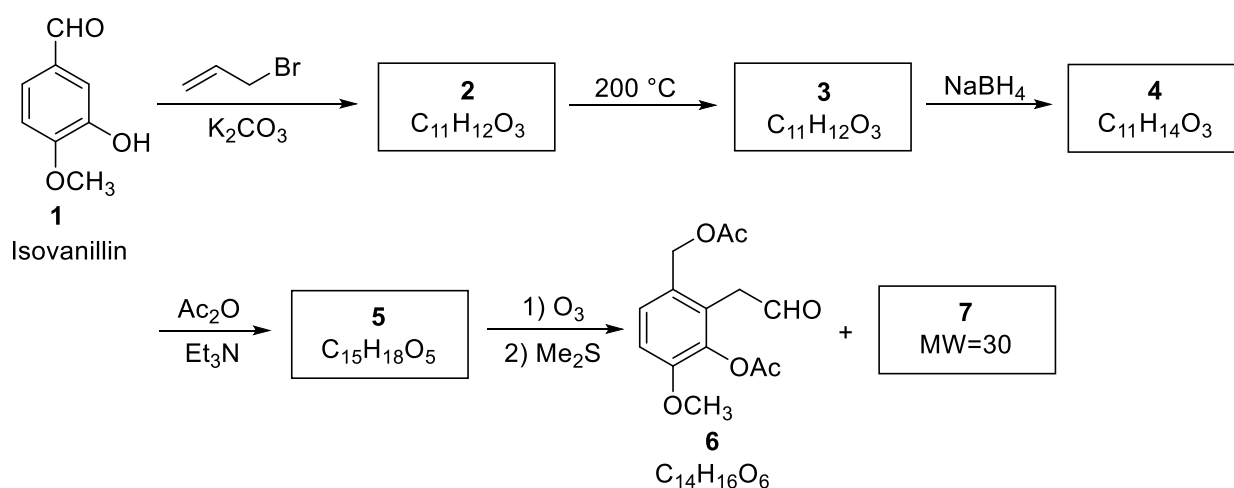

**18-1** Draw the structures of compounds 2, 3, 4, 5 and 7.

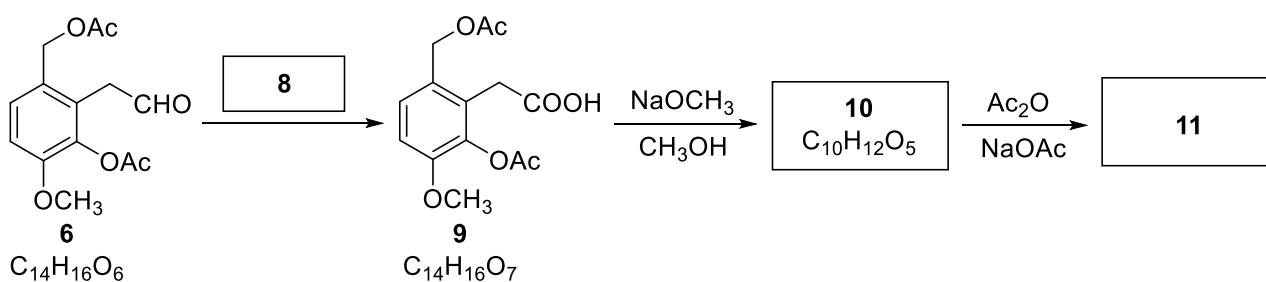

**18-2** From the following conditions, **choose** the correct condition for **8**.

- (a)  $\text{Ce}(\text{NH}_4)_2(\text{NO}_3)_6$                       (b)  $\text{CrO}_3(\text{Pyridine})_2$   
 (c)  $\text{H}_2\text{CrO}_4$                                       (d)  $\text{CH}_3\text{COCH}_3, \text{Al}[\text{O}^i\text{Pr}]_3$

**18-3** Draw the structure of compound **10**.

**18-4** Compound **11** contains a benzo-fused six-membered heterocycle structure. The  $^1\text{H}$  NMR spectrum of compound **11** gives the following data. Draw the structure of compound **11**.

$^1\text{H}$  NMR ( $\text{CDCl}_3$ )  $\delta$  2.32 (s, 3H), 3.54 (s, 2H), 3.79 (s, 3H), 5.23 (s, 2H), 6.84 (d,  $J = 9$  Hz, 1H), 7.04 (d,  $J = 9$  Hz, 1H).

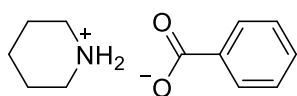
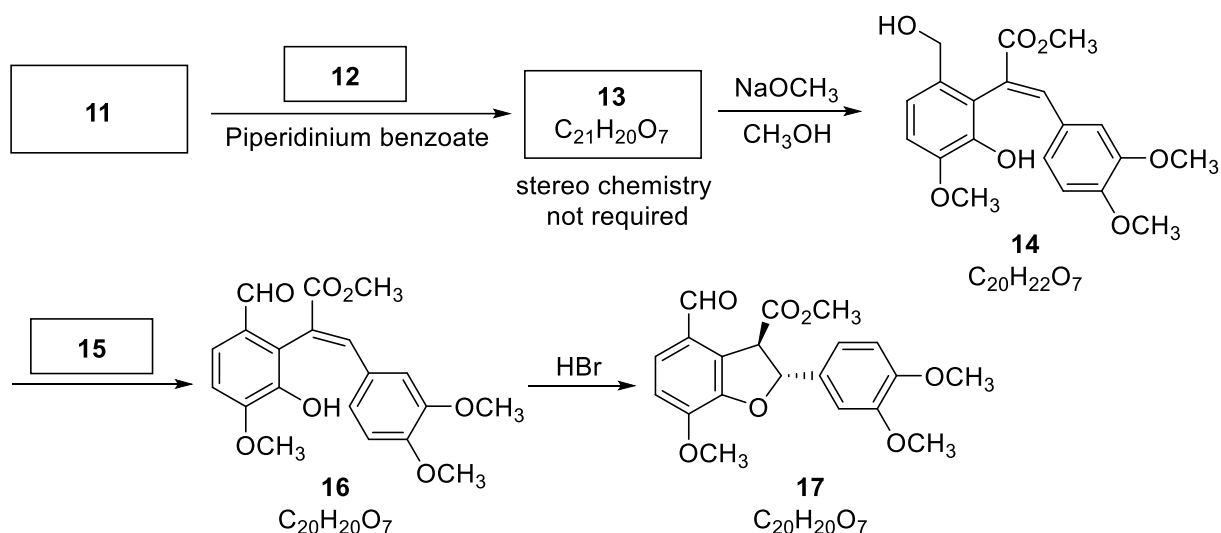

Piperidinium benzoate

**18-5 Draw** the structures of compounds **12** and **13**.

**18-6** From the following conditions, **choose** the correct condition for **15**.

- (a)  $\text{I}_2, \text{NaOH}$     (b)  $(\text{COCl})_2, \text{Me}_2\text{SO}$     (c)  $\text{Ag}(\text{NH}_3)_2\text{OH}$     (d)  $\text{CrO}_3, \text{H}_2\text{SO}_4$

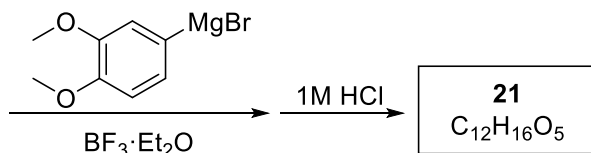
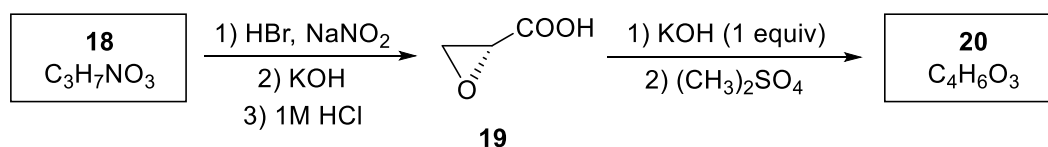

**18-7** Compound **18** is an  $\alpha$ -amino acid. **Draw** Fischer projection for compound **18** (Notice that the stereochemical configuration of the asymmetric carbon is inverted by the opposite-side substitution reaction from **18** to **19**).

**18-8 Assign** the absolute configuration of the center of chirality in compound **19** using the *R/S* nomenclature.

**18-9 Draw** the structure of compound **20** and clearly identify the stereochemistry.

**18-10 Draw** the structure of compound **21** and clearly identify the stereochemistry.

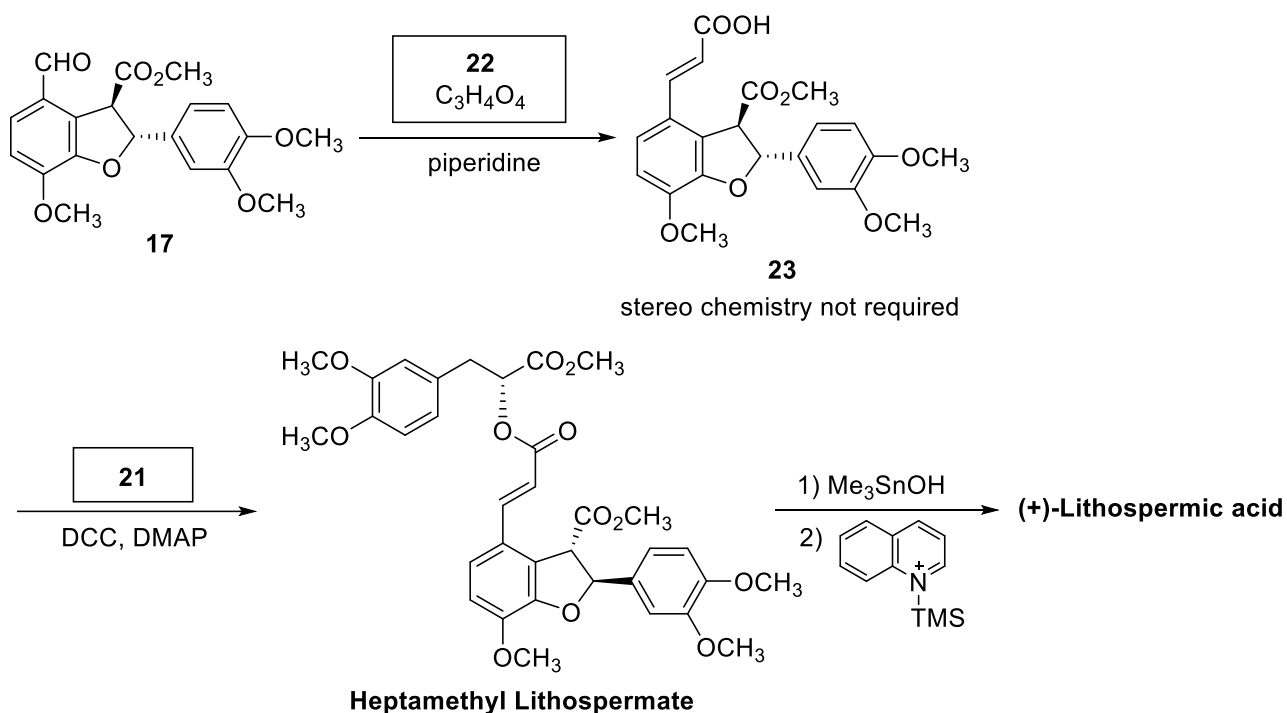

18-11 Draw the structure of compound 22.

## Problem 19. Reaction of peptides

The phenomenon of protein self-splicing was first discovered in 1990. As shown below, during the initial event in protein self-splicing, a peptide bonded to the nitrogen atom of an internal cysteine residue is usually cleaved by the side chain -SH group to yield a thioester intermediate **I**. Thioester **I** will undergo intramolecular ester exchange with another -SH group to give thioester **II**. After intramolecular cyclization with the adjacent amide group the third thioester **III** is formed, with will undergo acyl migration to give the final product **IV**.

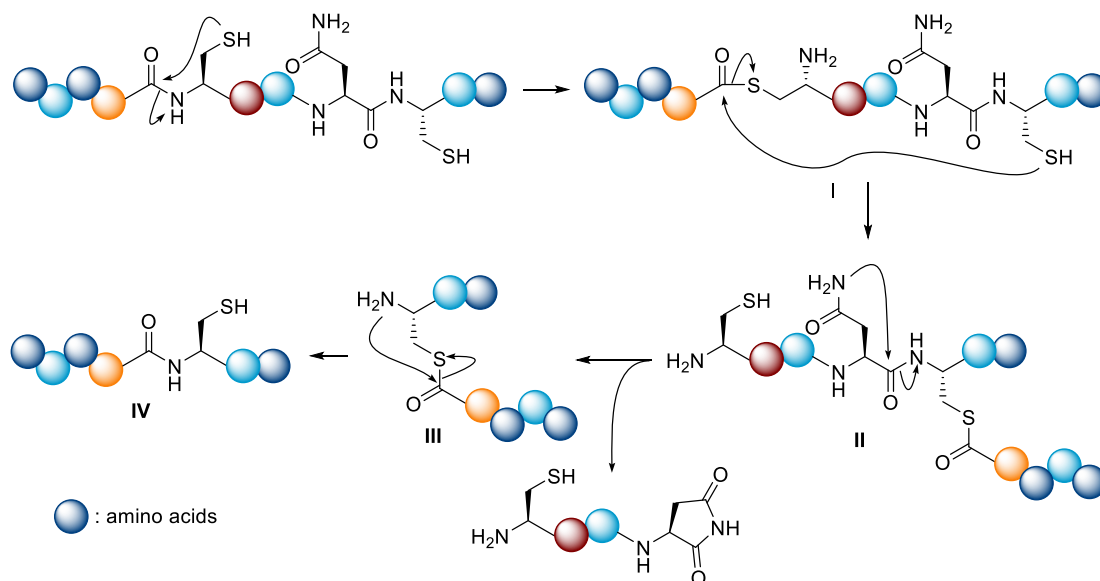

19-1 Based on the mechanism of protein self-splicing, a method for the synthesis of protein via

coupling of two peptides at the cysteine residue was developed. **Draw** the structures of intermediate **1**, by product **2** and the protein **3**, and clearly identify the stereochemistry.

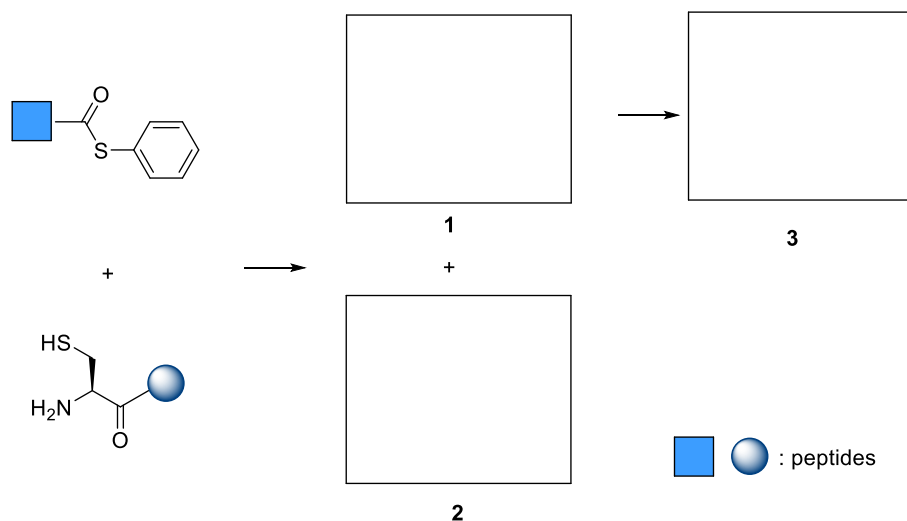

**19-2** Some cyclopeptide can also undergo intramolecular rearrangement via the same mechanism to give a new cyclopeptide. **Draw** the structure of compound **4**, and clearly identify the stereochemistry.

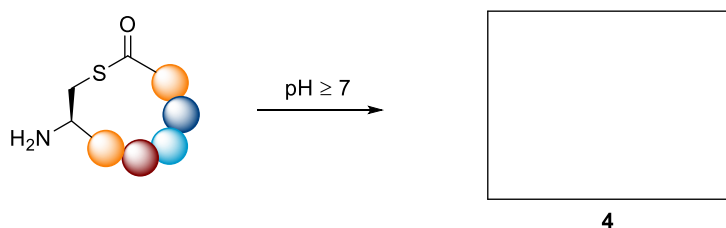

**19-3** The ester of salicylaldehyde can react with a peptide containing a cysteine residue at the N terminal to form a new amide bond. **Draw** the structures of intermediate **5** and by product **6** and clearly identify the stereochemistry.

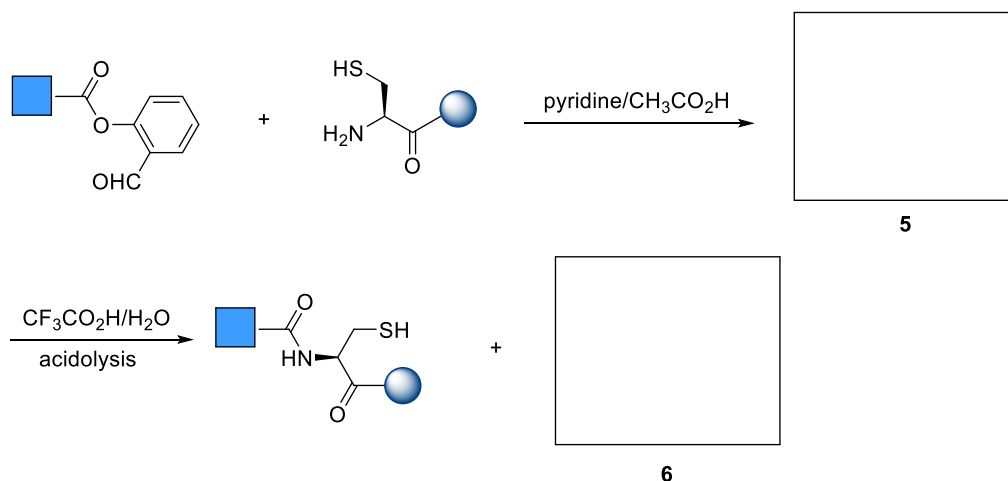

**19-4** The reaction of organic azides with trivalent phosphorous compounds to afford the corresponding azaylides is known as the Staudinger reaction. In certain cases Staudinger reactions were used to facilitate the formation of amide bonds. As shown below, the aza ylide intermediate **7** will form a bridged intermediate **8** and then give the amide product through hydrolysis. **Draw** the structures of intermediate **7** and **8**.

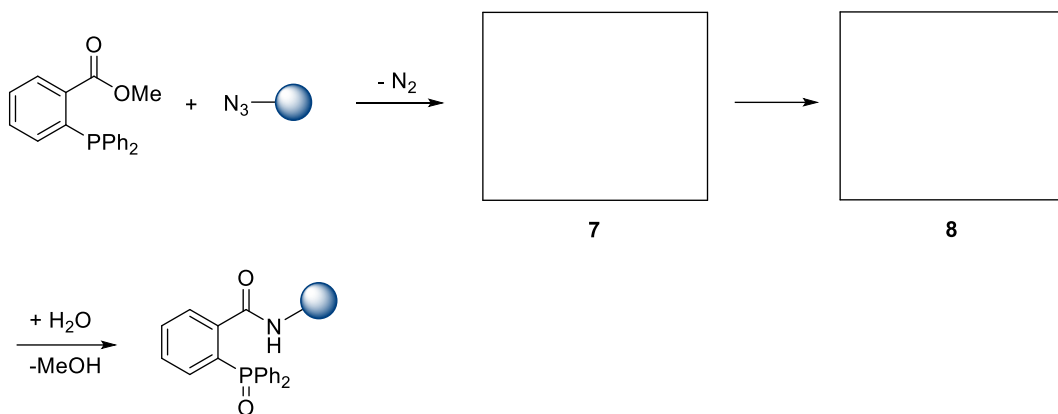

**19-5** Linear peptides containing cysteine and lysine can react with ortho-phthalaldehydes to give cyclopeptides with an isoindole linker.

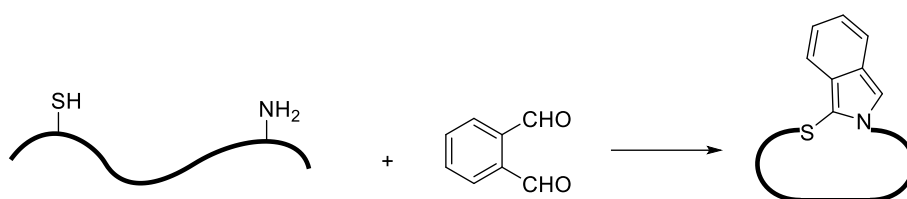

The mechanism of the reaction is shown below. **Draw** the structure of cyclic compound **9**.

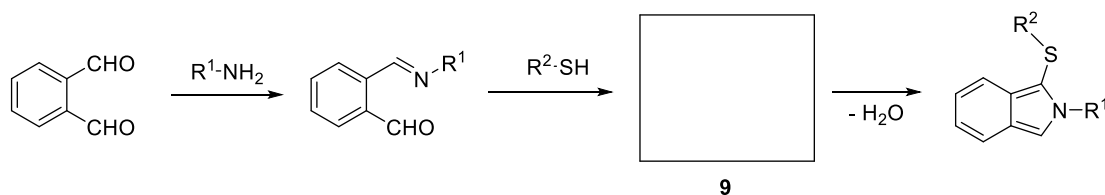

**19-6** Besides cysteine, methionine can be selectively labeled with oxaziridine-based reagents under biocompatible reaction conditions. As shown below, the reaction can undergo two different pathways.

**Draw** the structures of compounds **10**, **11**, **12**.

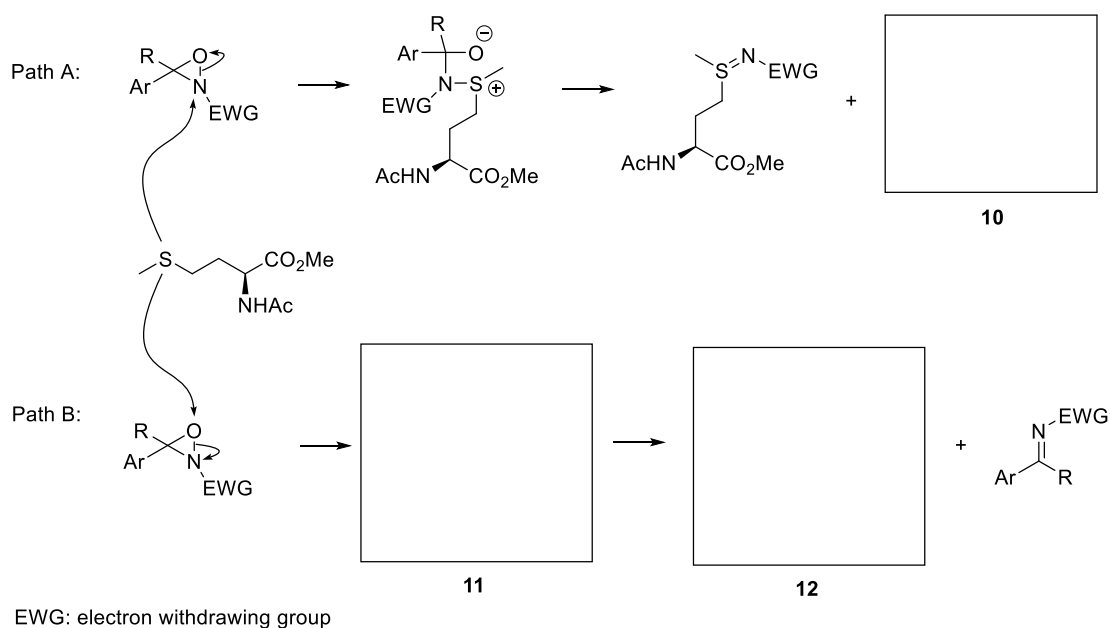



## Problem 20. Total Synthesis of Hapalindole-Type Natural Products

Hapalindole alkaloids are a group of structurally intriguing natural products exhibiting potent and exciting biological activities. There are many inspiring and creative synthetic strategies to address the construction of their challenging molecular architecture.

Phil Baran's group has developed a highly efficient strategy for quick assembly of the core structure of this family of natural product as depicted below.

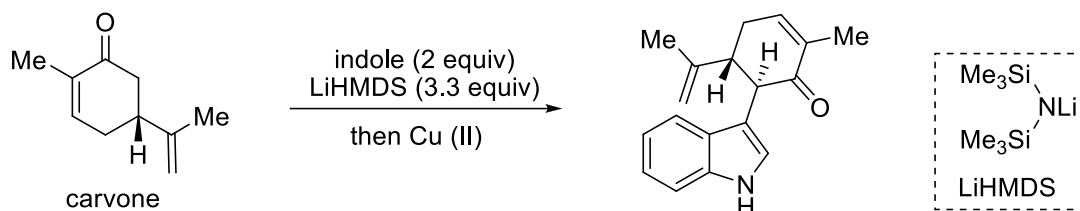

**20-1** Choose the correct statement indicating the reaction of carvone with indole/LiHMDS.

- (a) Electrophilic substitution;
- (b) Nucleophilic substitution;
- (c) Electrophilic addition;
- (d) Nucleophilic addition;
- (e) Radical coupling;

**20-2** From the following conditions, choose the best for the following reaction.

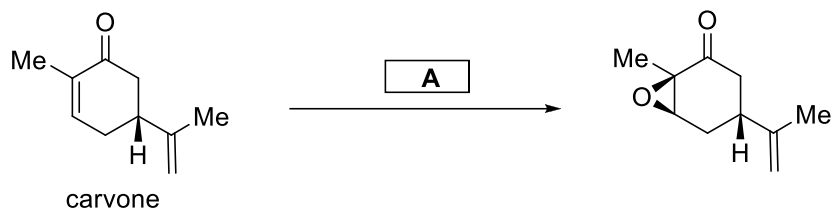

- (a) *m*-CPBA (*m*-chloroperbenzoic acid)
- (b) H<sub>2</sub>O<sub>2</sub>, NaOH
- (c) acetone, oxone (monopotassium peroxydisulfate)
- (d) BH<sub>3</sub>, then H<sub>2</sub>O<sub>2</sub>, NaOH

**20-3** Draw the structures of compounds **1-4** and clearly identify the stereochemistry where necessary.

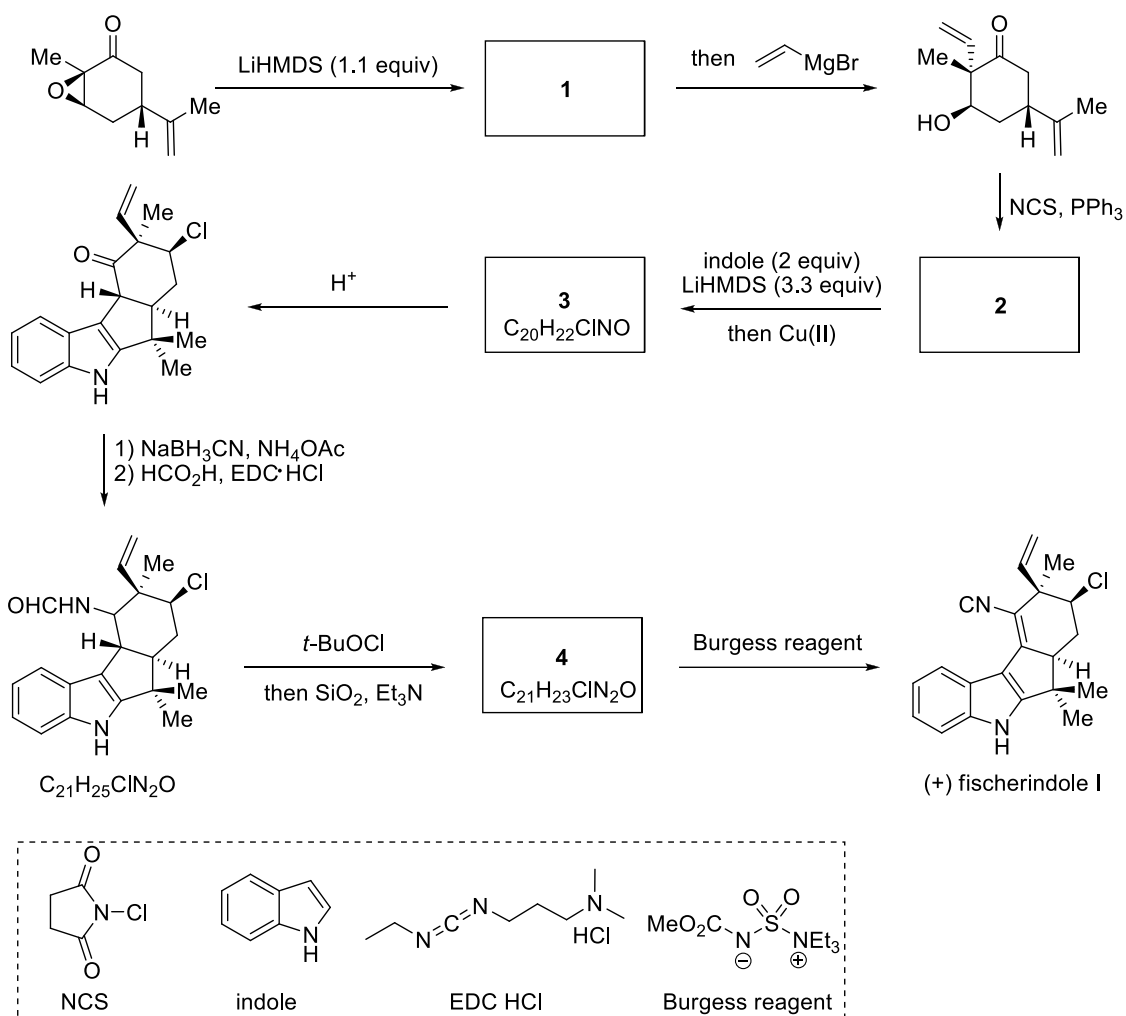

Ang Li's group has also done a dramatic contribution to the total synthesis of this family of natural products. Inspired by the proposed biosynthesis of the alkaloid, Ang Li's group has designed the following synthetic sequence for the quick construction of the core molecular skeleton.

**20-4 Draw** the structures of compounds **5** and clearly identify the stereochemistry where necessary.

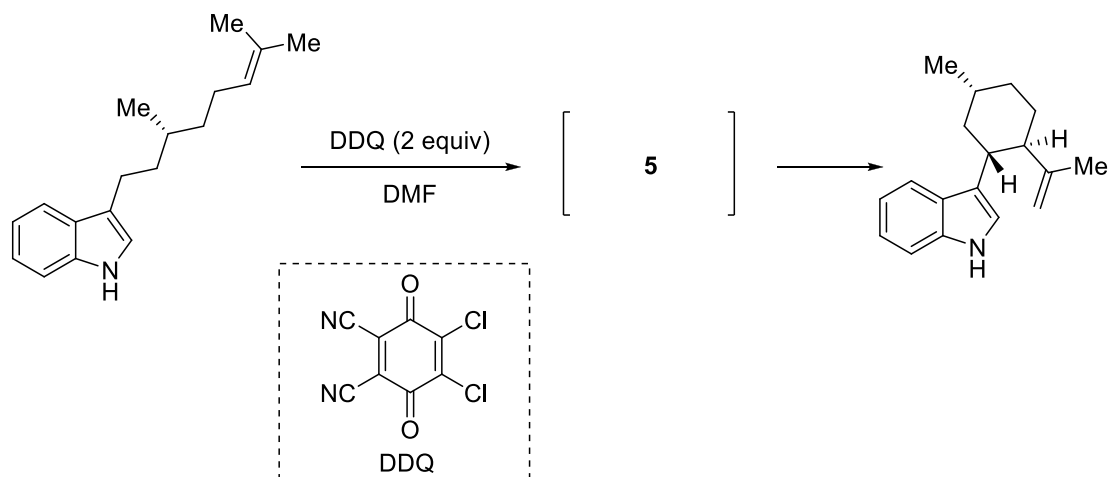

**20-5 Draw** the structures of compounds **6** and **7**.

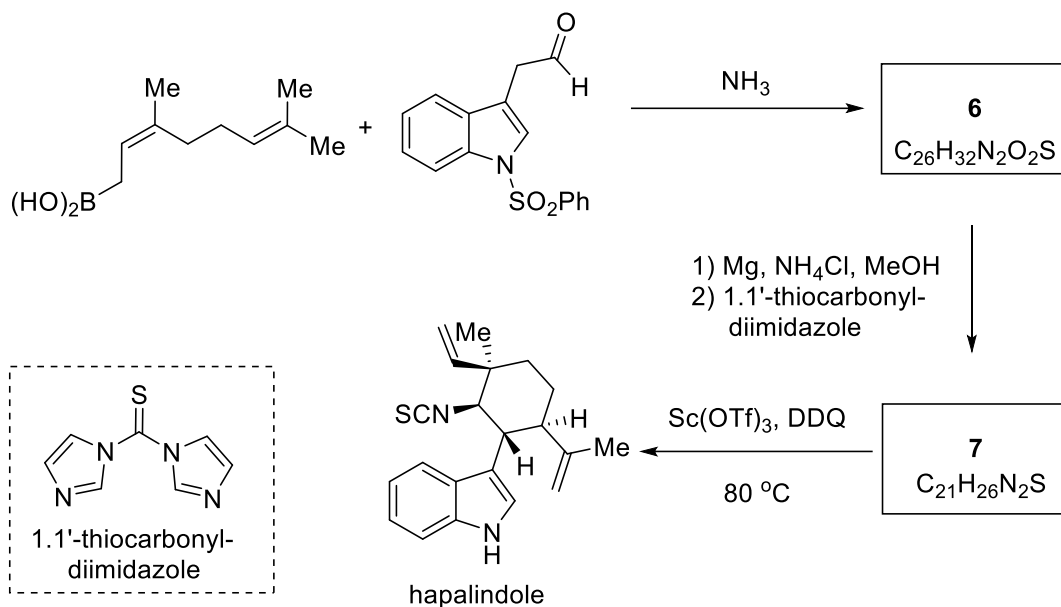

**20-6 Draw** the structures of compounds **8** and **9**.

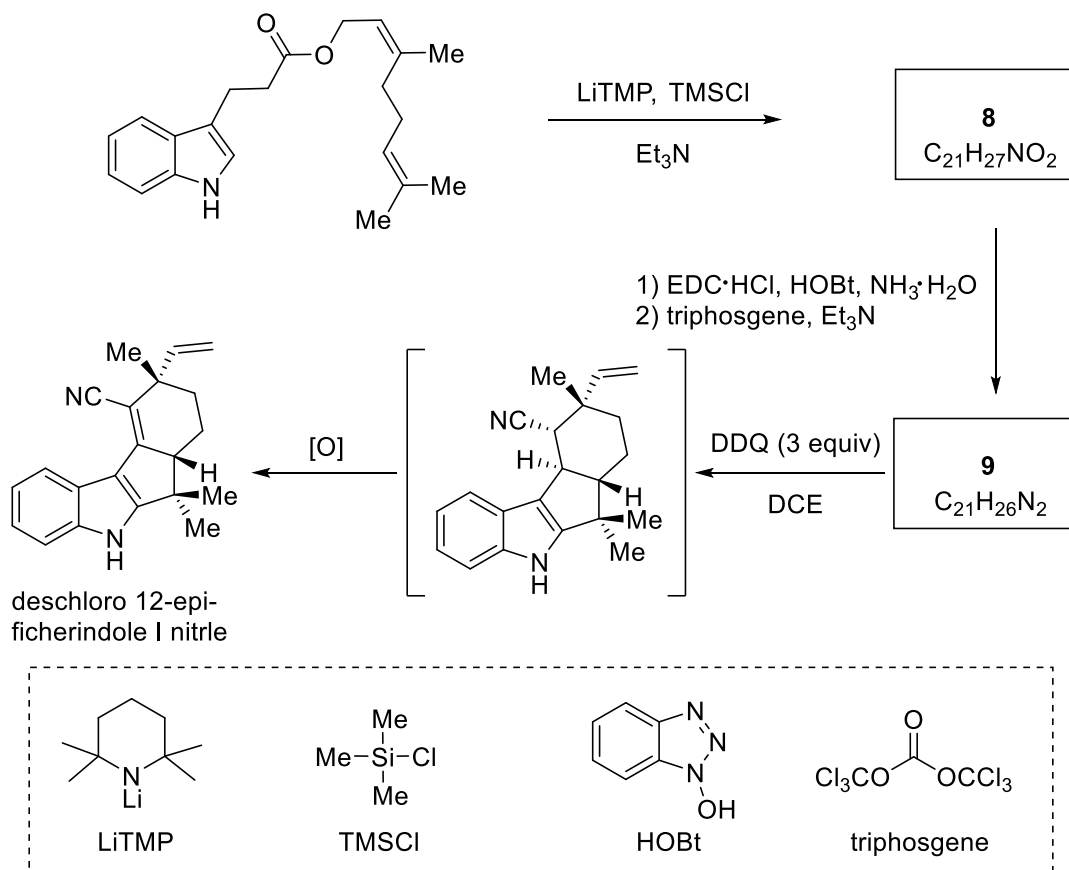

## Problem 21. Total Synthesis of Schindilactone A

Schindilactone A is a representative member of nortriterpenoids isolated from the plants of *Schisandraceae*, traditional Chinese herbal medicines with Chinese name Wuweizi (五味子) used for the treatment of rheumatic lumbago and related diseases. This molecule possesses a highly oxygenated framework bearing 12 stereogenic centers, eight of which are contiguous chiral centers located in the FGH tricyclic ring system, and an oxa-bridged ketal that lies within an unprecedented 7–8 fused carbocyclic core.

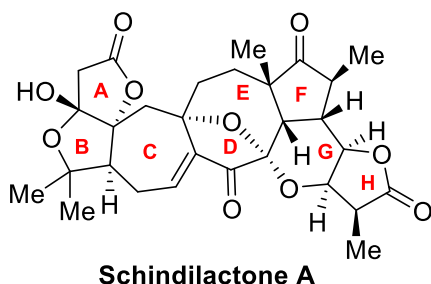

Wuweizi (五味子)

Please note that all formulae depicting chiral molecules in following questions refer to racemic mixtures.

**21-1** The first total synthesis of (±)-Schindilactone A began with the construction of B/C ring system. Thus, the key intermediate **8** was synthesized from **1** and **2** in 7 steps as shown below.

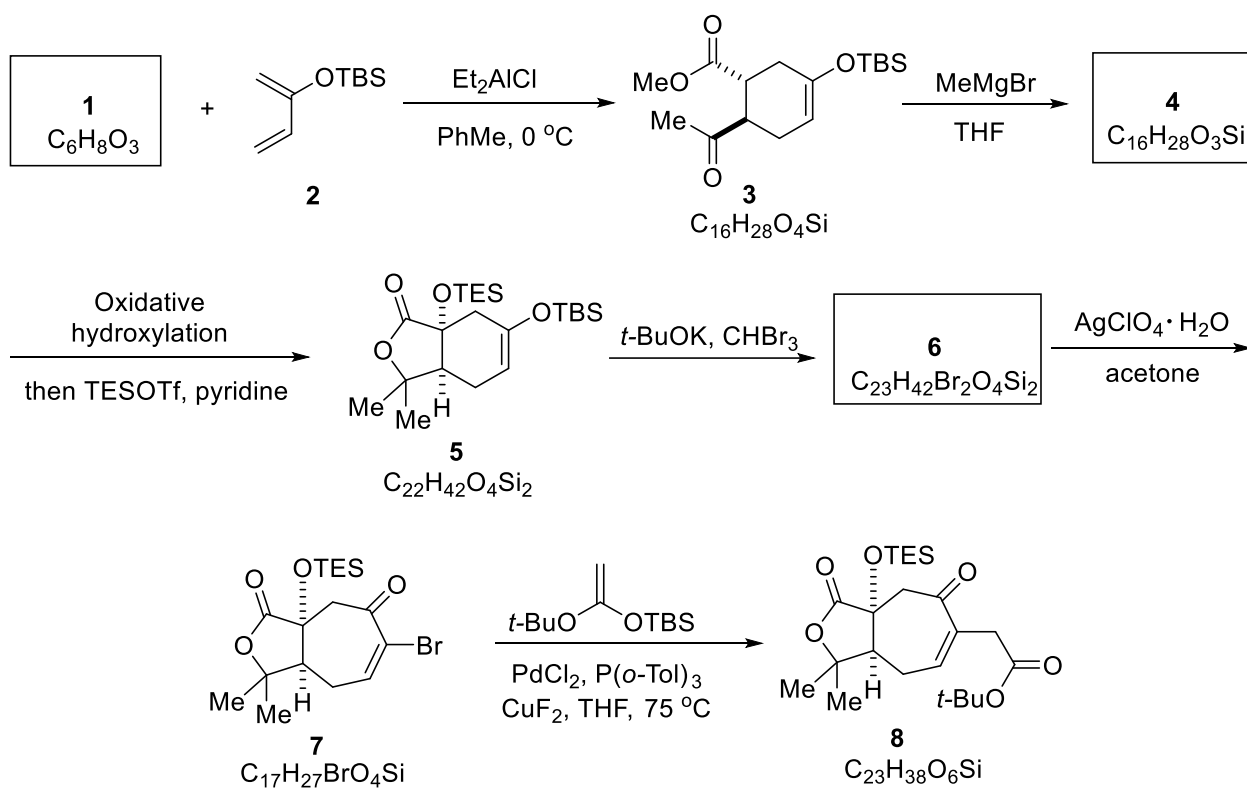

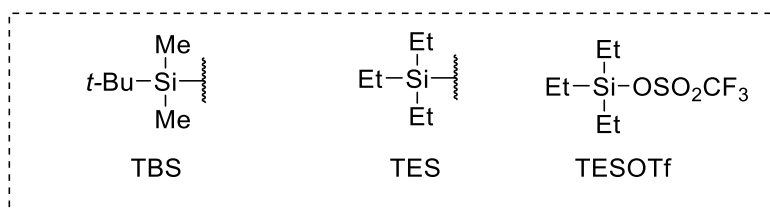

**21-1-1 Draw** the structures of compounds **1** and **4** and clearly identify the stereochemistry where necessary.

**21-1-2 Draw** two anion intermediates in the transformation from **3** to **4**.

**21-1-3** In the presence of a base, haloform can undergo an  $\alpha$ -elimination to form dihalocarbene. This reactive intermediate can be trapped by an alkene to give cyclopropanation product. For example, treatment of cyclohexene with chloroform and KOH leads to the synthesis of 7,7-dichlorobicyclo[4.1.0]heptane. **Draw** the structure of compound **6**.

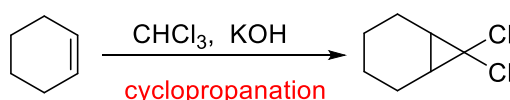
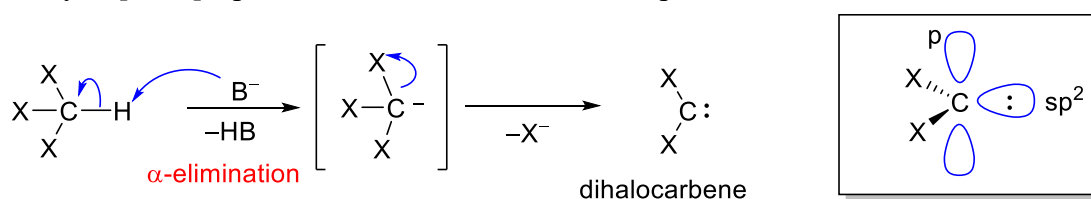

**21-2** Treatment of **8** with but-3-enyl magnesium bromide stereoselectively afforded **9**, which was oxidized to **10**. **Draw** the structure of **9**, including the appropriate stereochemistry.

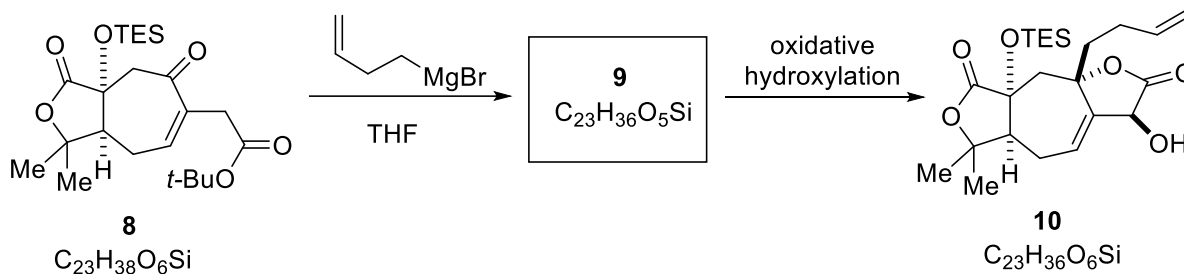

**21-3** Reaction of alcohol **10** with benzyl 2,2,2-trichloroacetimidate under the catalysis of trifluoromethanesulfonic acid (TfOH) afforded **11**. Treating **11** with vinyl magnesium bromide resulted in **12**, a key intermediate for the total synthesis of ( $\pm$ )-Schindilactone A.

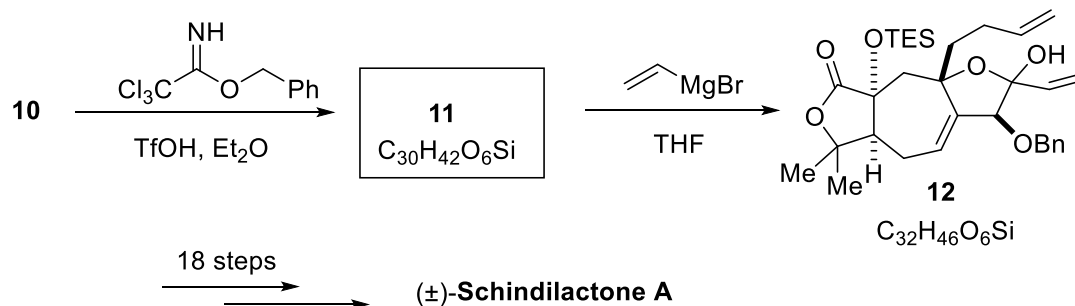

**21-3-1** Benzyl 2,2,2-trichloroacetimidate as a weak base can be protonated by an acid like TfOH, leading to activation of C–O bond of benzyloxy group. **Draw** the main resonance structures of conjugate acid of benzyl 2,2,2-trichloroacetimidate.

**21-3-2 Draw** the structure of **11**, including the appropriate stereochemistry

**21-3-3 Chose** the correct statement indicating the reaction of **10** with benzyl 2,2,2-trichloroacetimidate.

- (a) E2 reaction  
(b) S<sub>N</sub>1 reaction  
(c) S<sub>N</sub>2 reaction  
(d) Nucleophilic addition

**21-3-4 Draw** the structure of the by-product formed in the conversion of **10** into **11**. *Hint: this by-product contains three chlorine atoms.*

## Problem 22. Recyclable Plastic—Turning Waste into Treasure

White pollution creates serious damage to the environment and ecosystems, and the topic about recyclable plastic and degradable polymers has gained widespread attention in recent years. Polyethylene (PE) is the largest-volume plastic in the world, with annual production exceeding 100 million metric tons. In contrast to other plastics, PE is remarkably inert with necessitating pyrolysis temperature above 400 °C, which is due to all atoms of PE being connected by strong single C-C and C-H bonds, leading to tremendous stability. Therefore, to endow PE with degradability, we need to start with activation of C-H bond or C-C bond.

### Part A

A strategy for PE degradation has been developed by Chinese scientist, based on a tandem catalytic cross alkene metathesis shown below. First, the dehydrogenation catalyst removes hydrogen from both PE and a light alkane to form unsaturated species and [Ir-H<sub>2</sub>], then the alkene metathesis catalyst scrambles the alkenes, and finally hydrogenation of the newly formed alkenes with [Ir-H<sub>2</sub>] affords saturated alkanes. Consequently, the PE chain is cut into two pieces, and after multiple cycles with light alkanes, PE will be eventually converted to short hydrocarbons for industrial use as oil and waxes.

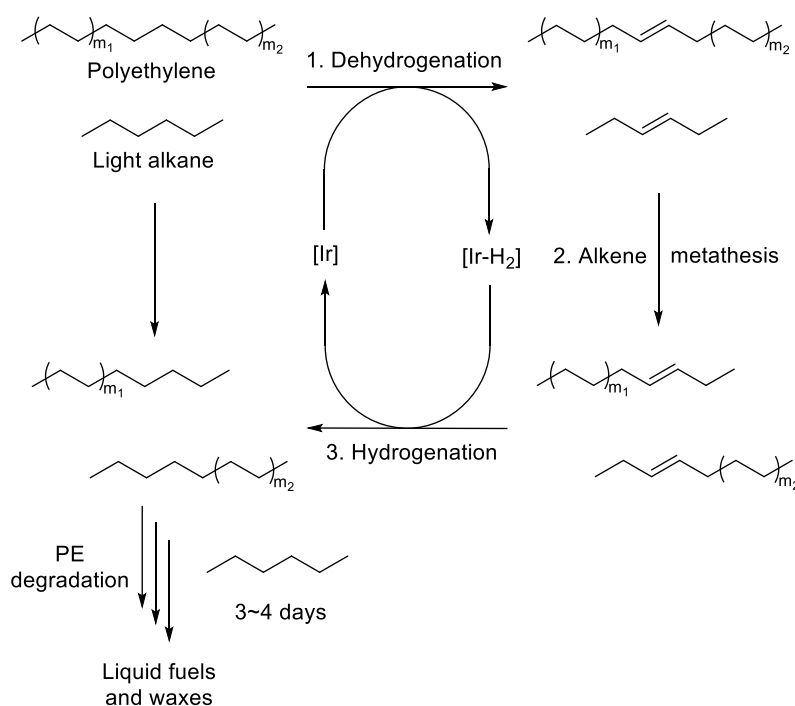

**22-1** The dehydrogenation and hydrogenation process require a coordination catalyst [Ir], the

synthetic route of which is shown below, **draw** the structures of **1** and **2**. Known that **2** contains two five-membered cycles.

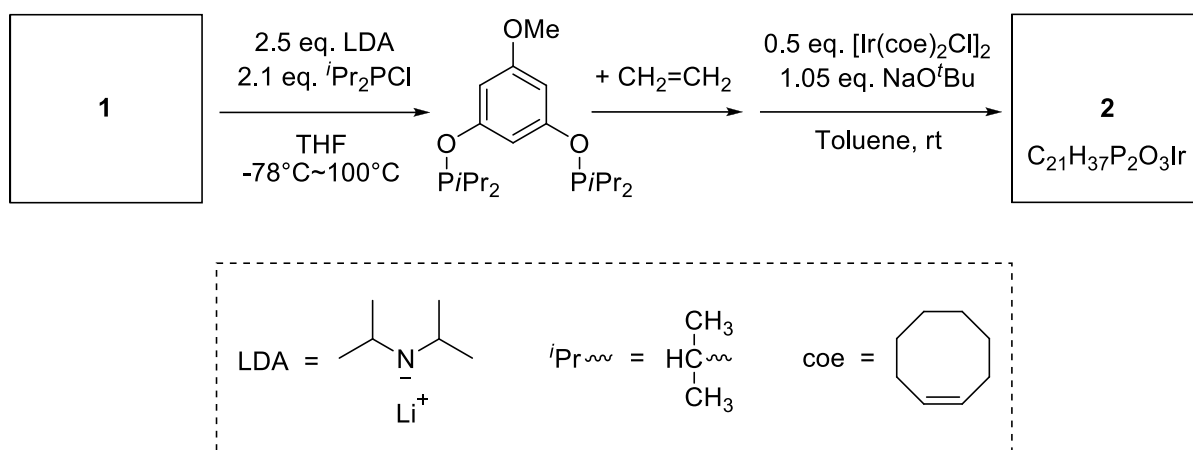

**22-2** To investigate the exact reaction site, PE is represented as  $(\text{---})_{m_1}\text{---}(\text{---})_{m_2}$ , and the light alkane added is represented as  $(\text{---})_{n_1}\text{---}(\text{---})_{n_2}$  (assume  $m_1 > m_2 \gg n_1 > n_2 > 0$ ), then the process can be simplified as follow (the symbol '>>' means 'far more than'):

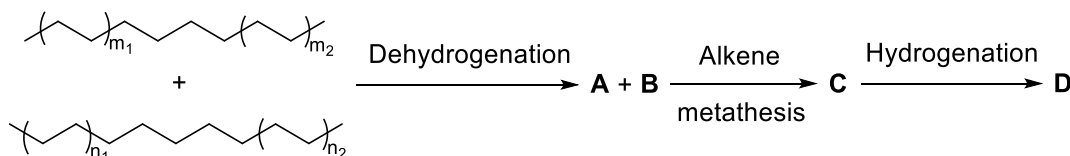

Assuming that in the first step, there are 3 different kinds of **A**, the dehydrogenation product of PE (the possible dehydrogenation site:  $(\text{---})_{m_1}\text{---}(\text{---})_{m_2}$ ). Similarly, there are 4 different kind of **B**, the dehydrogenation product of light alkane (regardless of geometric isomerism, assuming that  $n_1$  and  $n_2$  are too small for being regarded as polymers).

After one cycle of reactions, there are **at most** \_\_\_\_\_ possible kinds of polymers in mixture **C**.

**22-3** In question 1.2, if in the real reaction  $m_1 = 40$  and  $m_2 = 38$  (also with 3 possible dehydrogenation site), the light alkane added is n-hexane ( $\text{CH}_3\text{-CH}_2\text{-CH}_2\text{-CH}_2\text{-CH}_2\text{-CH}_3$ ), and the hexane may dehydrogenate anywhere to form  $\text{C}=\text{C}$  double bond, then after one cycle of reactions, there are **at most** \_\_\_\_\_ possible kinds of polymers in mixture **D**.

**22-4** Actually most of the polymer materials contain side chain or heteroatoms, which are not that 'stubborn' as PE and more suitable for other degradation methods. **Choose** the polymer material from below that is the most suitable for degradation by alkene metathesis.

- (a) Polypropylene    (b) Phenolic Resin    (c) Polyamide    (d) Polyurethane

**22-5** The early polymer degradation mainly relies on thermolysis. At certain temperature, firstly the C-C bond in the polymer main chain breaks into free radicals, and then comes to other reactions. Think about why thermolysis of PMMA (polymethyl methacrylate) mainly produces monomers (MMA, methyl methacrylate), while thermolysis of PE produces only 1% of monomer and a lot of fragments with large molecular weight? According to the following polymer structure, **choose** the most appropriate reason.

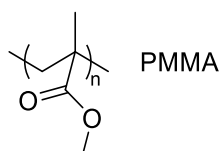

- (a) PMMA doesn't melt when heated, but PE melts first when heated.
- (b) PMMA contains hydrolyzable ester side groups, but PE is non-hydrolyzable.
- (c) PMMA has lower thermolysis temperature, but that of PE is higher.
- (d) PMMA side groups stabilizes free radicals, but free radicals from PE is unstable.

## Part B

It is reported that by introducing low density of oxygen-containing functional groups into the hydrocarbon chain, the crystalline structure and the desirable material properties of PE can be fully retained with great recyclability (recovery rate > 96%). These so called "PE" are actually polyesters, which can be synthesized by monomers from biorefining of plant oils:

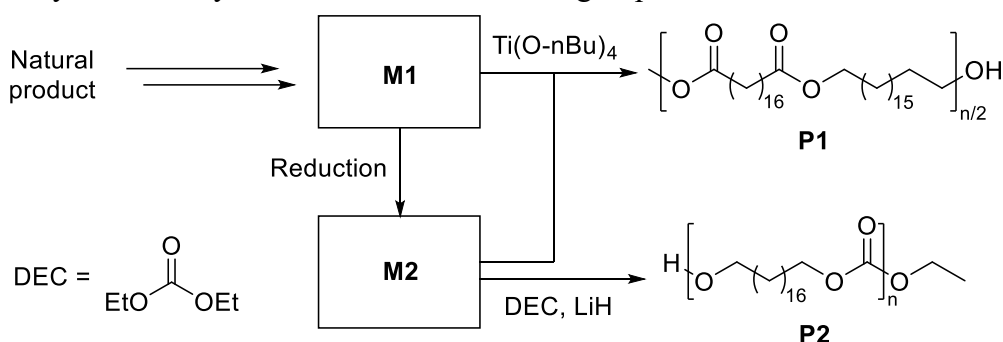

**22-6 Why** these polymers are degradable?

- (a) The polymers contain carbon and hydrogen, which is flammable.
- (b) The polymer materials have great mechanical properties.
- (c) The polymer chain contains ester bonds, which can be nucleophilic attacked.

**22-7** The structure and synthetic route of polymer **P1** and **P2** is shown above. **P1** is polymerized from monomer **M1** and monomer **M2**, **P2** is polymerized from monomer **M2**, **M2** can be reduced from **M1**. **Draw** the structure of monomer **M1** and **M2**.

**22-8** The FT-IR spectrum results of two polymers are shown below, **distinguish** whether they belong to **P1** or **P2**.

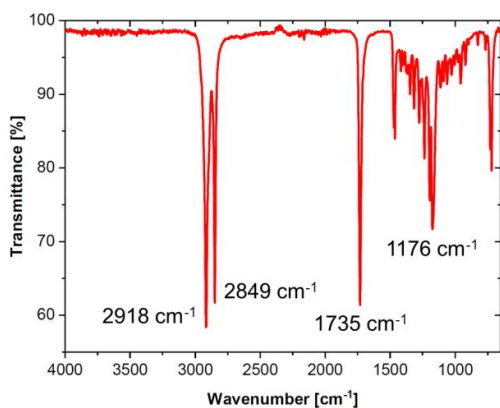

P1  P2

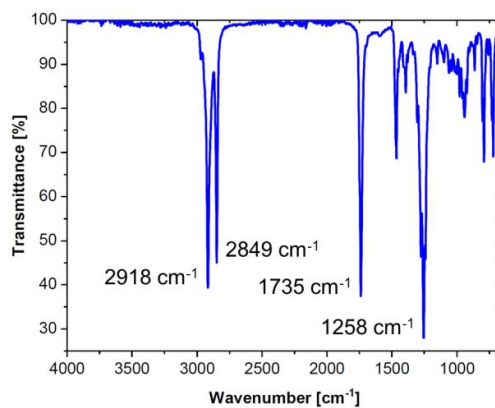

P1  P2



**22-9** Polymer **P1** and **P2** can be almost completely degraded, and their degradation products can be recycled for synthesis of new materials. Choose the correct degradation mixture under different conditions and **mark** whether they are **R1**, **R2** and **R3**.

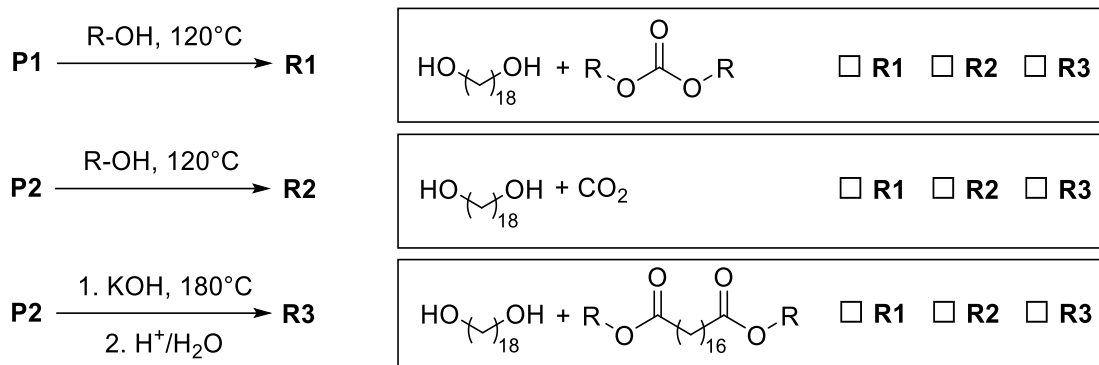

### Problem 23. The combustion of water gas

Water gas is a mixture of  $\text{H}_2$  (g) and  $\text{CO}$  (g) with the molar ratio of 1:1. In order to achieve its complete combustion, the amount of  $\text{O}_2$  provided in the form of air (21%  $\text{O}_2$  and 79%  $\text{N}_2$ ) should be twice of the amount needed from the reaction. At 298 K, the thermodynamic data of the species involved in the reactions are listed in the table below.

	H <sub>2</sub> O(g)	CO(g)	N <sub>2</sub> (g)	O <sub>2</sub> (g)	CO <sub>2</sub> (g)
$\Delta_f H_m^\ominus$ (298K) (kJ mol <sup>-1</sup> )	-241.83	-110.52			-393.51
$\Delta_f G_m^\ominus$ (298K) (kJ mol <sup>-1</sup> )		-137.27			-394.38
$C_{p,m}^\ominus$ (J mol <sup>-1</sup> K <sup>-1</sup> )	33.58	29.14	29.12	29.36	37.13

Assume that  $C_{p,m}^\ominus$  does not change with temperature.

**23-1 Calculate** the highest temperature that the system can reach if the initial temperature is 298 K, the pressure is maintained constant at  $10^5$  Pa, and the combustion proceeds in an adiabatic manner.

**23-2** The enthalpy and entropy changes with temperature are given by the equations:

$$\Delta_r H_m^\ominus(T_2) = \Delta_r H_m^\ominus(T_1) + \Delta_r C_p^\ominus (T_2 - T_1)$$

$$\Delta_r S_m^\ominus(T_2) = \Delta_r S_m^\ominus(T_1) + \Delta_r C_p^\ominus \ln \frac{T_2}{T_1}$$

**Calculate** the  $\Delta_r G_m^\ominus$  of the reaction  $\text{CO(g)} + \frac{1}{2} \text{O}_2(\text{g}) \longrightarrow \text{CO}_2(\text{g})$  at 310 K.

## Problem 24. The thermodynamics of decomposition reactions

The thermodynamic data of the species involved in the reactions are listed in the table below:

	Ag <sub>2</sub> CO <sub>3</sub> (s)	Ag <sub>2</sub> O(s)	CO <sub>2</sub> (g)
$\Delta_r H_m^\ominus$ (298K) (kJ mol <sup>-1</sup> )	-501.66	-30.58	-393.51
$S_m^\ominus$ (298K) (J mol <sup>-1</sup> K <sup>-1</sup> )	167.4	121.8	213.8
$C_{p,m}^\ominus$ (J mol <sup>-1</sup> K <sup>-1</sup> )	109.6	65.7	37.6

**24-1** The decomposition of Ag<sub>2</sub>CO<sub>3</sub> proceeds with the chemical equation: Ag<sub>2</sub>CO<sub>3</sub>(s) → Ag<sub>2</sub>O(s) + CO<sub>2</sub>(g). **Calculate** the standard equilibrium constant,  $K_p^\ominus$ (298 K), of the reaction at 298 K.

**24-2** The enthalpy and entropy changes with temperature are given by the equations:

$$\Delta_r H_m^\ominus(T_2) = \Delta_r H_m^\ominus(T_1) + \Delta_r C_p^\ominus(T_2 - T_1)$$

$$\Delta_r S_m^\ominus(T_2) = \Delta_r S_m^\ominus(T_1) + \Delta_r C_p^\ominus \ln \frac{T_2}{T_1}$$

In order to dry Ag<sub>2</sub>CO<sub>3</sub>(s) with a hot air flow under a constant pressure of 10<sup>5</sup> Pa and a constant temperature of 383 K, **calculate** the minimum partial pressure of CO<sub>2</sub>(g) needed in the air flow to avoid the decomposition of Ag<sub>2</sub>CO<sub>3</sub>(s).

**24-3** The decomposition of 1 mol of PCl<sub>5</sub>(g) in a sealed, expandable container proceeds with the chemical equation: PCl<sub>5</sub>(g) → PCl<sub>3</sub>(g) + Cl<sub>2</sub>(g). The density of the gas mixture is measured to be 4.80 kg m<sup>-3</sup> at 10<sup>5</sup> Pa and 440 K after the system reaches equilibrium. Assume that all the species are ideal gases, **calculate** the  $\Delta_r G_m^\ominus$  of this reaction at 440 K.

**24-4** If the PCl<sub>5</sub>(g) decomposition system is maintained at pressure of 10<sup>5</sup> Pa, and contains inert Ar with a partial pressure of 0.5 × 10<sup>5</sup> Pa, **calculate** the percentage of decomposition.

## Problem 25. The condensation of 1-butanol vapor

In order to condense the vapor of 1-butanol at 273 K, the supersaturation ratio (the ratio between the actual vapor pressure needed for the condensation and the saturated vapor pressure on top of a flat liquid surface) has to be 4. At 273 K, the surface tension of 1-butanol,  $\sigma$ , is 2.61 × 10<sup>-2</sup> N m<sup>-1</sup>, density,  $\rho$ , is 0.81 × 10<sup>3</sup> kg m<sup>-3</sup>, and molar mass,  $M$ , is 74 × 10<sup>-3</sup> kg mol<sup>-1</sup>. The relationship between the saturated vapor pressure on top of a curved surface,  $p$ , and the saturated vapor pressure on top of a flat surface,  $p_0$ , is given by the Kelvin equation:

$$\ln \frac{p}{p_0} = \frac{2\sigma M}{\rho R T r}, \text{ where } R \text{ is the ideal gas constant,}$$

$T$  is the temperature, and  $r$  is the radius of liquid droplet.

**25-1 Calculate** the radius of the droplet when the supersaturation ratio is 4.

**25-2 Calculate** the number of molecules in the 1-butanol droplet.

## Problem 26. Chemical kinetics

The decomposition reaction of a compound  $A_2B$  proceeds with the chemical equation  $2A_2B \xrightarrow{k} 2A_2 + B_2$ , and the reaction rate equation follows  $r = kc_{A_2B}^2$ . The kinetic data of the system is given in the table below:

Temperature (K)	967	967	1030	1030
Initial concentration of $A_2B$ ( $\text{mmol dm}^{-3}$ )	156	39	7	49
First half-life of $A_2B$ (s)	380	1520	1442	206

**26-1 Calculate** the activation energy  $E_a$ , and the reaction rate constant  $k$  at both 967 K and 1030 K.

**26-2** If the initial concentration of  $A_2B$  at 1030 K is  $54 \text{ mmol dm}^{-3}$ , **calculate** the time taken for the conversion rate of  $A_2B$  to reach 37%.

**26-3** The reaction,  $A \rightarrow C$ , can occur by two different mechanisms (Fig. 26):

(a) The reaction  $A \xrightarrow{k_a} C$  occurs directly, and the half-life is not related to the initial concentration. At 294 K, the half-life is 1000 min, and at 340 K, the time needed for the concentration of A decreases to 1/1024 of the original concentration is 0.10 min.

(b) The reaction proceeds in two steps:

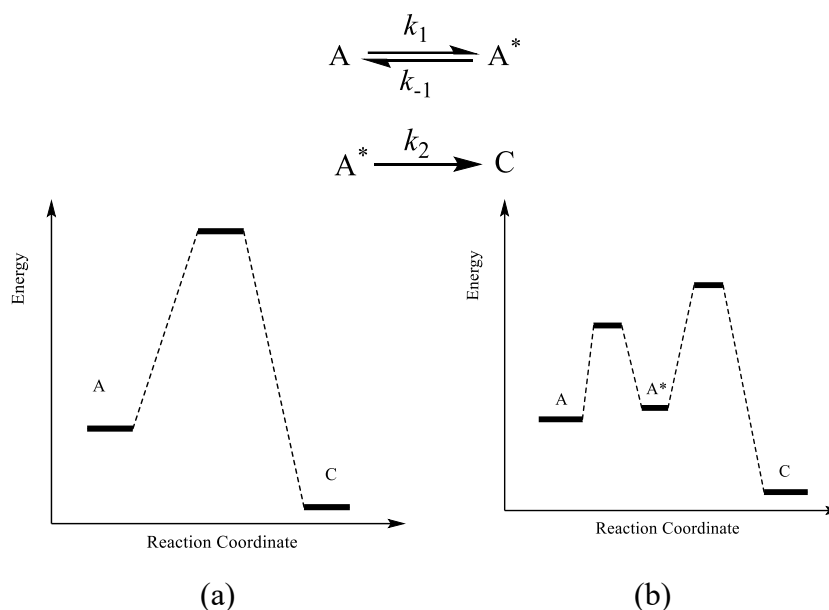
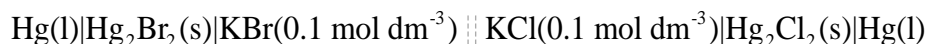

Figure 26 The potential energy profiles of the two mechanisms

The activation energies for the involved steps are:  $E_{a,1} = 125.5 \text{ kJ mol}^{-1}$ ,  $E_{a,-1} = 120.3 \text{ kJ mol}^{-1}$ ,  $E_{a,2} = 167.4 \text{ kJ mol}^{-1}$ . Assume that the pre-exponential factors of these two mechanisms are the same, and both of the activation energies and the pre-exponential factors do not change with temperature. **Calculate** the ratio between the rates of the two mechanisms,  $r_b/r_a$ , at 500 K.

## Problem 27: Electrochemistry

The cell potential  $E$  of the following battery:



changes with temperature  $T$  under the relationship  $E = a - bT$ , where the unit of  $E$  is V, the unit of temperature is K,  $a = 0.1318 \text{ V}$ , and  $b = 1.58 \times 10^{-5} \text{ V K}^{-1}$ . At a certain temperature of  $T$ , the cell potentials of a calomel electrode with a concentration of  $0.1 \text{ mol dm}^{-3}$  KCl solution are  $E_{\text{Cl}^-|\text{Hg}_2\text{Cl}_2|\text{Hg}} = 0.3335 \text{ V}$  and  $E_{\text{Hg}_2^{2+}|\text{Hg}} = 0.799 \text{ V}$ .

**27-1 Write** the electrode half-reactions and cell reaction of this cell when there are two electrons involved in the reactions.

**27-2** The temperature coefficient of the standard cell potential could be used to calculate the standard entropy of the cell reaction, with the equation of  $\frac{dE_{\text{cell}}^{\ominus}}{dT} = \frac{\Delta_r S^{\ominus}}{zF}$ . **Calculate** the  $\Delta_r H_m^{\ominus}$  of the cell reaction at 298.15 K.

**27-3** Calculate the solubility (with the unit of  $\text{mol dm}^{-3}$ ) and solubility product,  $K_{\text{sp}}^{\ominus}$ , of a saturated  $\text{Hg}_2\text{Br}_2$  solution at 298.15 K.

## Problem 28. $\pi$ -conjugated systems

Particle in a box and Hückel molecular orbital (HMO) theory are the two simple models to describe the state of  $\pi$  electrons in conjugated molecules.

The  $\pi$  electrons in linear polyenes can be viewed as particles moving in a one-dimensional box. Assuming that a linear polyene molecule is composed of  $2k$  C atoms, the lengths of all the C=C double bonds and C-C single bonds are  $d$ , the length of the one-dimensional box  $l$  is  $(2k + 1)d$ , and the energies of the electrons in the box are defined by the formula  $E_n = \frac{n^2 h^2}{8ml^2}$  ( $n = 1, 2, \dots$ ), where  $m$  is the mass of electron and  $h$  is Planck's constant.

**28-1 Calculate** the energy differences of the lowest unoccupied molecular orbital (LUMO) and the highest occupied molecular orbital (HOMO), i.e.  $\Delta E = E_{\text{LUMO}} - E_{\text{HOMO}}$ , of (a) 1, 3-butadiene, (b) 1, 3, 5-hexatriene, (c) 1, 3, 5, 7-octatetraene.

**28-2 Sort** the max. wavelengths of the absorption spectra,  $\lambda_{a, \text{max}}$ ,  $\lambda_{b, \text{max}}$  and  $\lambda_{c, \text{max}}$ , of these three molecules in increasing order.

Based on experimental evidence, the  $\lambda_{\text{max}}$  calculated from the above model has non-negligible errors, thus the  $\Delta E$  should further be modified by the formula:

$$\Delta E' = E_{\text{LUMO}} - E_{\text{HOMO}} + 3.25 \times 10^{-19} \left( 1 - \frac{1}{2k} \right) \text{J}.$$

**28-3** Assuming that the  $\lambda_{\max}$  of 1, 3, 5-hexatriene is 268 nm, **calculate**  $d$ .

The electrons in anthracene can be viewed as particles moving in a two-dimensional box whose length is  $a$  and width is  $b$ . The energies of the  $\pi$  electrons in the box are defined by:

$$E_{n_x, n_y} = \frac{h^2}{8ml^2} \left( \frac{n_x^2}{a^2} + \frac{n_y^2}{b^2} \right) (n_x = 1, 2, \dots; n_y = 1, 2, \dots).$$

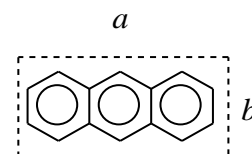

**28-4** The  $\lambda_{\max}$  of its absorption spectrum is 357 nm. Assuming  $a = 3b$ , **calculate**  $b$ .

When treating linear polyenes with the HMO theory, the energies of the  $\pi$  electrons are defined by  $E_n = \alpha + 2\beta \cos \frac{n\pi}{2k+1}$  ( $n=1, 2, \dots, 2k$ ), where  $\alpha$  and  $\beta$  are negative numbers, and  $\alpha$  represents the energy of an electron in an isolated  $2p_z$  orbital, and  $\beta$  is the interaction energy between two neighboring  $2p_z$  orbitals.

**28-5 Calculate** the energy levels of all the occupied orbitals and HOMO of 1, 3, 5-hexatriene.

The energy levels of the  $\pi$  molecular orbitals of polyacenes include  $E = \alpha + \beta$  and  $E = \alpha - \beta$ , and the rest of the  $4N$  energy levels are given by

$$E = \alpha \pm \frac{\beta}{2} \left[ 1 \pm \sqrt{9 + 8 \cos \left( \frac{p\pi}{N+1} \right)} \right] (p = 1, 2, 3, \dots, N)$$

**28-6** The  $\lambda_{\max}$  of its absorption spectrum is 357 nm, **calculate** the value of  $\beta$ .

## Practical Tasks

## Safety

All students participating in the International Chemistry Olympiad are assumed to be trained by basic knowledge about how to do experiments properly and safely in a chemical laboratory.

All participating students should be aware of all relevant rules and safety procedures and obey the specific safety rules in their country. If there is any question concerning safety procedures during the practical exam, the student should not hesitate to ask the nearest supervisor for direction.

The Preparatory Practical Tasks are designed to be carried out in properly equipped chemical laboratories under mentor's supervision **only**. We did not include specific and detailed safety and disposal instructions as regulations are different in each country. Mentors must carefully adapt the problems accordingly.

The GHS hazard statements (H-phrases) associated with the chemicals used are indicated in the tasks. Their meanings are as follows:

### Physical Hazards

H225 Highly flammable liquid and vapor.

H226 Flammable liquid and vapor.

H251 Self-heating; may catch fire.

H272 May intensify fire; oxidizer.

H290 May be corrosive to metals.

### Health Hazards

H301 Toxic if swallowed.

H302 Harmful if swallowed.

H303 Maybe harmful if swallowed.

H304 May be fatal if swallowed and enters airways.

H311 Toxic in contact with skin.

H312 Harmful in contact with skin.

H314 Causes severe skin burns and eye damage.

H315 Causes skin irritation.

H316 Causes mild skin irritation.

H317 May cause an allergic skin reaction.

H318 Causes serious eye damage.

H319 Causes serious eye irritation.

H331 Toxic if inhaled.

H332 Harmful if inhaled.

H333 May be harmful if inhaled.

H334 May cause allergy or asthma symptoms or breathing difficulties if inhaled.

H335 May cause respiratory irritation.

H336 May cause drowsiness or dizziness.

H341 Suspected of causing genetic defects.

H350 May cause cancer.

H351 Suspected of causing cancer.

H371 May cause damage to organs

# P1. Extraction of Berberine and Its Structural Characterization

Berberine **1a** is a quaternary protoberberine alkaloid from plants like *Coptis chinensis*. It has been used as an OTC (Over-the-Counter) drug in China for many years for a great variety of biological and pharmacological activities such as bacterial-caused diarrhea, antimicrobial, antiplasmodial, antidiarrheal and cardiovascular. The berberine hydrochloride **1b** is typically yellow and soluble in ethanol and boiling water except in cold water.

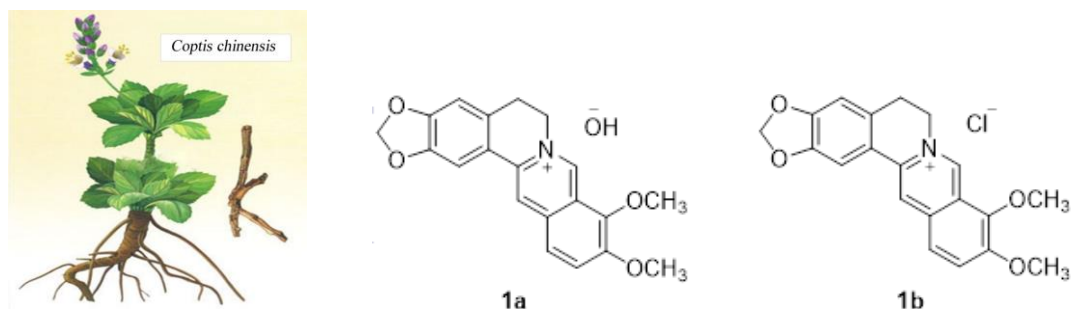

In this task, berberine **1a** will be extracted from the powder root of *Coptis chinensis* by Soxhlet extractor and transferred to hydrochloride (**1b**). The molecular structure of **1b** will be characterized by proton nuclear magnetic resonance (H-NMR).

## Chemicals

Substance	Name	State	GHS Hazard Statement
C <sub>2</sub> H <sub>5</sub> OH	Absolute ethanol	Liquid	H225, H316, H319
C <sub>3</sub> H <sub>6</sub> O	Acetone	Liquid	H225, H316, H319, H336
HCl	Hydrochloride acid (1 mol L <sup>-1</sup> )	Aqueous solution	H290, H314, H318
C <sub>2</sub> H <sub>4</sub> O <sub>2</sub>	Acetic acid (1%)	Aqueous solution	H315, H319
H <sub>2</sub> O	Distilled water	Liquid	Non-hazardous

## Glassware and equipment

- 1 Goggle glass
- 4 Round bottom flasks (50 mL)
- 2 Condenser
- 3 Spatulas
- 1 Weighing balance (0.01 g)
- 1 Magnetic stirrer with stir bars
- 4 Pasteur pipettes
- 1 Filter funnel (small)
- 1 Filtering flask
- 1 Aspirator
- 1 Laboratory stand
- 2 Beaker (100 mL)
- 2 Erlenmeyer flasks (100 mL)
- 1 Glass rod



- 1 Rotary evaporator
- 1 Soxhlet extractor
- 1 Dropper
- 1 Scissors
- 1 Graduated cylinder (25 mL)
- 1 NMR tube
- 1 Watch glass
- 1 Ice water bath
- 1 Infra-red lamp (800 W)
- 1 NMR instrument

### Other materials

- Weighing paper
- Filter paper
- Absorbent cotton
- Coptis chinensis root (Alternative plants: berberidaceae, fimariaceae and papeveraceae).

### Experimental procedure

1. Add 20 mL ethanol to a round bottom flask (50 mL) equipped with a Soxhlet extractor and a condenser as shown below.

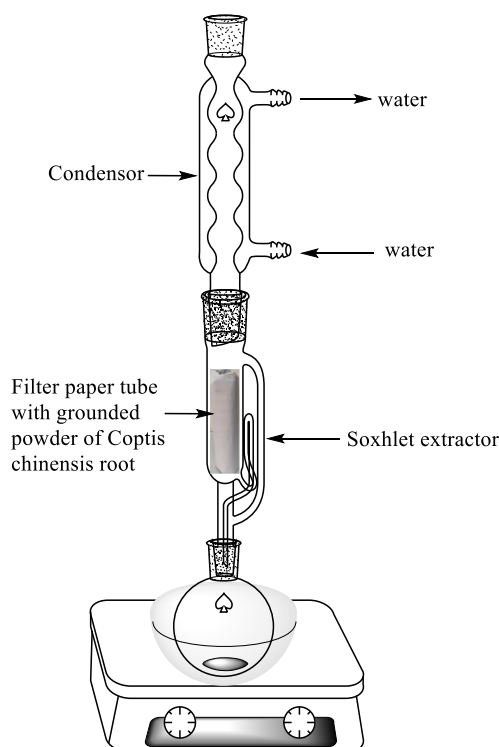

2. Add 2 g of grounded powder of coptis chinensis root to filter paper tube in Soxhlet extractor. Reflux and extract continuously for 1 h under stirring and water-bath heating.
3. Stop heating immediately when the solution leaves from the Soxhlet extractor to the round bottom flask completely.
4. Remove most of the ethanol by distillation with rotary evaporator after cooling down.

- Add 6 mL acetic acid solution (1%) to the round bottom flask and dissolve the residue by heating.
- Filter the hot solution to remove the insoluble.
- Add hydrochloride acid solution (1 mol L<sup>-1</sup>) to the filtrate dropwise until the solution become turbid.
- Cool with an ice water bath to precipitate the yellow needle crystals.
- Filter under reduced pressure and wash the crystals twice by distilled water (2 mL × 2) and by acetone (2 mL).
- Transfer the crystals to a watch glass, dry under an infra-red lamp for 15 min and weigh the product **1b**.

### Questions

- Calculate the yield.
- Analysis NMR spectra of the product provided by a technician.

## P2. Synthesis of (2,4-Dichlorophenoxy)acetic Acid and Evaluation of Product Purity

(2,4-Dichlorophenoxy)acetic acid (2,4-D) is a systemic herbicide used in the control of broadleaf weeds and is also a synthetic auxin often used in laboratories for plant research. Due to the longevity and extent of use, 2,4-D is one of the most thoroughly studied herbicides with respect to its environmental properties. Generally, 2,4-D is not harmful to human health or the environment when used according to the instructions in the label.

In recent years, the synthesis and applications of 2,4-D have been paid continuous attention from quite a lot of Chinese scientists. In this task, 2,4-D will be synthesized from 2,4-dichlorophenol and 2-chloroacetic acid as raw materials and the purity of the product will be evaluated by acid-base titration.

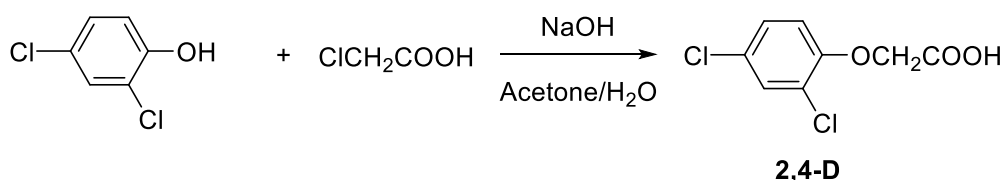

### Chemicals

Substance	Name	State	GHS Hazard Statement
C <sub>6</sub> H <sub>4</sub> Cl <sub>2</sub> O	2,4-dichlorophenol (provided by mentor)	Solid	H302, H311, H314
C <sub>2</sub> H <sub>3</sub> ClO <sub>2</sub>	2-chloroacetic acid (provided by mentor)	Liquid	H301, H311, H314, H318, H335

HCl	Aqueous hydrochloric acid (1 mol L <sup>-1</sup> )	Aqueous solution	H301, H314, H318
NaOH	Sodium hydroxide (8 mol L <sup>-1</sup> )	Aqueous solution	H290, H314, H318
C <sub>3</sub> H <sub>6</sub> O	Acetone	Liquid	H225, H316, H319, H336
NaOH	NaOH standard solution (0.1 mol L <sup>-1</sup> )	Aqueous solution	H290, H314, H318
HCl	HCl standard solution (0.1 mol L <sup>-1</sup> )	Aqueous solution	H301, H314, H318
C <sub>20</sub> H <sub>14</sub> O <sub>4</sub>	Phenolphthalein (PP) (0.2% in ethanol)	Ethanol solution	H225, H319
NaCO <sub>3</sub>	Anhydrous sodium carbonate	Solid	H303, H319
C <sub>14</sub> H <sub>14</sub> N <sub>3</sub> NaO <sub>3</sub> S	Methyl orange (MO) (0.1%)	Aqueous solution	Non-hazardous
H <sub>2</sub> O	Distilled water	Liquid	Non-hazardous

### Glassware and equipment

- 1 Goggle glass
- 1 Laboratory stand
- 1 Three-neck round bottom flask (100 mL) with 3 stoppers
- 1 Thermometer (150 °C)
- 1 Condenser
- 1 Buchner Funnel
- 1 Glass rod
- 1 Scissors
- 1 Weighing balance (0.01 g)
- 1 Weighing balance (0.1 mg)
- 2 Spatulas
- 2 Beaker (250 mL)
- 1 Magnetic stirrer with stir bars
- 1 Dropper
- 1 Aurilave
- 1 Graduated cylinder (25 mL)
- 1 Watch glass
- 1 Ice water bath
- 1 Filtering flask
- 1 Aspirator
- 3 Erlenmeyer flasks (250 mL)
- 2 Burettes (50 mL) with Teflon plug
- 1 Laboratory stand with burette clamp
- 1 Volumetric pipette (25 mL)
- 1 Pipetting ball
- 3 Weighing bottles (25 × 25 mm)

1 Infra-red lamp (800 W)

### Other materials

pH indicator paper

Filter paper

Weighing paper

### Experiment procedure

#### I. Synthesis of (2,4-Dichlorophenoxy)acetic Acid

1. Add 4.8 mL chloroacetic acid (80 mmol. **This step should be carried out by mentor!**), 20 mL acetone and 20 mL NaOH solution ( $8 \text{ mol L}^{-1}$ ) to a three-neck round bottom flask (100 mL), stir for 5 min under room temperature.
2. Add 13.0 g 2,4-dichlorophenol (80 mmol. **This step should be carried out by mentor!**) to the reaction bottle, heat to  $90^\circ\text{C}$ , and stir for 1 h.
3. Pour the reaction solution into a beaker (250 mL), add aqueous HCl ( $1 \text{ mol L}^{-1}$ ) dropwise till pH value of 3-4.
4. Cool the solution by ice water bath to precipitate the solid product.
5. Collect solid product by suction filtration. Wash the product with distilled water ( $5 \text{ mL} \times 2$ ).
6. Dry under an infra-red lamp for 15 min and weigh the product.

#### II. Calibration of NaOH standard solution

7. Weigh 0.4-0.6 g potassium hydrogen phthalate (decrement method) accurately to an Erlenmeyer flask (250 mL) and add 50 mL distilled water.
8. After complete dissolution of potassium hydrogen phthalate, add 2 drops PP, titrate with NaOH standard solution till the ending-point. Repeat the titration 3 times. Calculate the concentration of NaOH standard solution.

#### III. Calibration of HCl standard solution

9. Weigh 0.20-0.25 g anhydrous sodium carbonate (decrement method) accurately to an Erlenmeyer flask (250 mL) and add 30 mL distilled water.
10. After complete dissolution of sodium carbonate, add 2 drops MO, titrate with HCl standard solution till the ending-point. Repeat the titration 3 times. Calculate the concentration of HCl standard solution.

#### IV. Purity analysis of the product

11. Weigh 0.25-0.30 g product (decrement method) accurately to an Erlenmeyer flask, add 25.00 mL NaOH standard solution, shake the flask for 1 min to accelerate the reaction, add 2 drops PP, titrate by HCl standard solution till the ending-point. Repeat the titration 3 times.

### Questions

1. **Represent** the one side reaction by reaction formula.
2. **Calculate** the yield.
3. **Calculate** the purity of the product.
4. **Why** can't the product be titrated directly by NaOH standard solution?
5. **Why** is PP used as indicator instead of MO in procedure 11?

### P3. Enzymatic Protein Digestion

As the central molecule of life, protein participates in almost all biological processes. Trypsin is one of the major proteolytic enzymes that usually found in the digestive system of many vertebrates. Trypsin catalyzes the hydrolysis of proteins into short peptides and amino acids, providing raw materials for the human body to synthesize new protein.

In this task, trypsin (TYP) will be employed to catalyze the hydrolysis of casein ( $M_w = 24$  kDa) to amino acids. The concentration of the amino acids will be determined in formaldehyde titration method. Then solve the maximum velocity of the reaction ( $V_{\max}$ ) and the Michaelis constant ( $K_m$ ) of TYP under the given experimental condition using Lineweaver-Burk plot (or double reciprocal plot).

Michaelis–Menten equation

$$V = \frac{V_{\max} [S]}{K_m + [S]}$$

Taking the reciprocal gives us

$$\frac{1}{V} = \frac{K_m + [S]}{V_{\max} [S]} = \frac{K_m}{V_{\max}} \frac{1}{[S]} + \frac{1}{V_{\max}}$$

in which

$V$ : velocity of the reaction

$K_m$ : Michaelis constant

$V_{\max}$ : maximum velocity of the reaction

$[S]$ : substrate concentration

Formaldehyde titration is a method to titration of amino acid with sodium hydroxide in the presentation of formaldehyde. The mechanism is shown as follow:

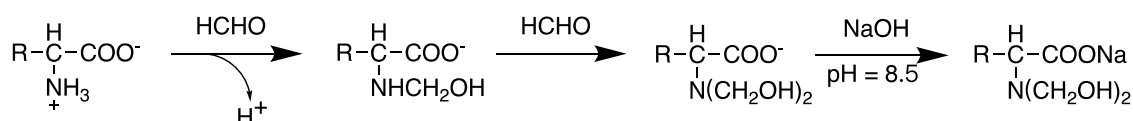

These chemical reactions ensure the release of  $\text{H}^+$  of amino acids, thereby allowing the accurate

determination of the concentration of amino acids in the solution by titration with sodium hydroxide.

### Chemicals

Substances	Name	State	GHS hazard statements
H <sub>2</sub> O	Deionized water	Liquid	Non-hazardous
TYP	TYP solution (1 mg mL <sup>-1</sup> )	Aqueous solution	H315, H319, H334, H335
CH <sub>2</sub> O-C <sub>20</sub> H <sub>14</sub> O <sub>4</sub>	formaldehyde-phenolphthalein solution, pH 7.0, 100 mL (Detailed in the <b>Experiment procedure for mentors</b> )	Aqueous solution	H302, H315, H317, H318, H332, H341, H350, H371
Casein	Casein solutions ( <b>A-C</b> ), varied concentrations (see the table), in Erlenmeyer flasks	Aqueous solution	Non-hazardous
C <sub>20</sub> H <sub>14</sub> O <sub>4</sub>	Phenolphthalein (PP) (0.2% in ethanol)	Ethanol solution	H225, H319
NaOH	Sodium hydroxide (0.1 mol L <sup>-1</sup> )	Aqueous solution	H290, H314

The protein concentrations of casein solutions (Casein, **A-C**) are listed in the following table.

Label	<b>A</b>	<b>B</b>	<b>C</b>
Casein concentration (g L <sup>-1</sup> )	10	20	30

### Glassware and equipment

- 3 Erlenmeyer flasks (150 mL)
- 9 Erlenmeyer flasks (50 mL)
- 1 Burette (50 mL)
- 3 Volumetric pipettes (10 mL)
- 1 pipetting ball
- 20 Pasteur pipette (plastic)
- 1 Water bath
- 1 Waste bottle (1 L) labeled as WASTE

### Experiment procedure for mentors

The formaldehyde-phenolphthalein solution, pH 7.0 needs to be prepared freshly by mentors before the experiment.

1. Prepare 100 mL formaldehyde solution (10%, m/v) by diluting 36% stock formaldehyde solution with deionized water.
2. Add 1 mL 0.2% phenolphthalein-ethanol solution into the 10% formaldehyde solution.

3. Titrate the solution with  $0.1 \text{ mol L}^{-1}$  NaOH. The ending-point is indicated as the first visible color change of the mixture to light pink.
4. Transfer the solution (100 mL) into a glass bottle labeled as “formaldehyde-phenolphthalein solution, pH 7.0”.

### Experiment procedure

#### I. Catalytic hydrolysis of casein by trypsin

1. Pick 3 Erlenmeyer flasks (50 mL) and add 5 mL of formaldehyde-phenol-phthalein solution into each flask. Label the flasks with 1 to 3 (**Flask 1-3**).
2. Pick 1 Erlenmeyer flasks (150 mL) and add 50 mL of casein solution (**A**) into the flask. Keep the flask in water bath ( $37 \text{ }^{\circ}\text{C}$ ) for 10 min.
3. At the same time as Step 2, put the bottle of TYP in the water bath ( $37 \text{ }^{\circ}\text{C}$ ) and incubate for 10 min.
4. Transfer 5 mL of TYP solution into the flask with casein (**A**). Mix well and start the timer.
5. Transfer 10 mL of the reaction mixture into the 50 mL flasks labeled 1, 2, and 3 (**Flask 1-3**) at 2 min, 4 min, and 6 min, respectively.
6. Repeat steps 1-5 to complete the experiments with casein solutions **B** and **C**.

#### II. Determination of the amino acid concentrations after hydrolysis with formaldehyde titration

7. Add 10 drops of phenolphthalein-ethanol solution into each of the 50 mL Erlenmeyer flask containing the samples.
8. Titrate the mixture in the 50 mL Erlenmeyer flasks with  $0.1 \text{ mol L}^{-1}$  NaOH. The endpoint is indicated as the first visible color change of the mixture to light pink. Write down the volume (mL) of NaOH consumed in the following table.

Samples	Casein <b>A</b>			Casein <b>B</b>			Casein <b>C</b>		
	1	2	3	1	2	3	1	2	3
Volume of NaOH / mL									

9. Pour all the solutions in the Erlenmeyer flasks (50 mL and 150 mL) into the bottle labeled WASTE.

### Data analysis and questions

1. **Calculate** the amino acid concentrations of the mixtures according to the titration results

Samples	Casein <b>A</b>			Casein <b>B</b>			Casein <b>C</b>		
	1	2	3	1	2	3	1	2	3
Amino acid concentration / $\text{mol L}^{-1}$									

2. **Calculate** the initial velocity of the reaction ( $v_{10}$ ,  $v_{20}$ ,  $v_{30}$ ) of enzymatic protein hydrolysis by plotting amino acid concentrations against time according to the data in the above table.

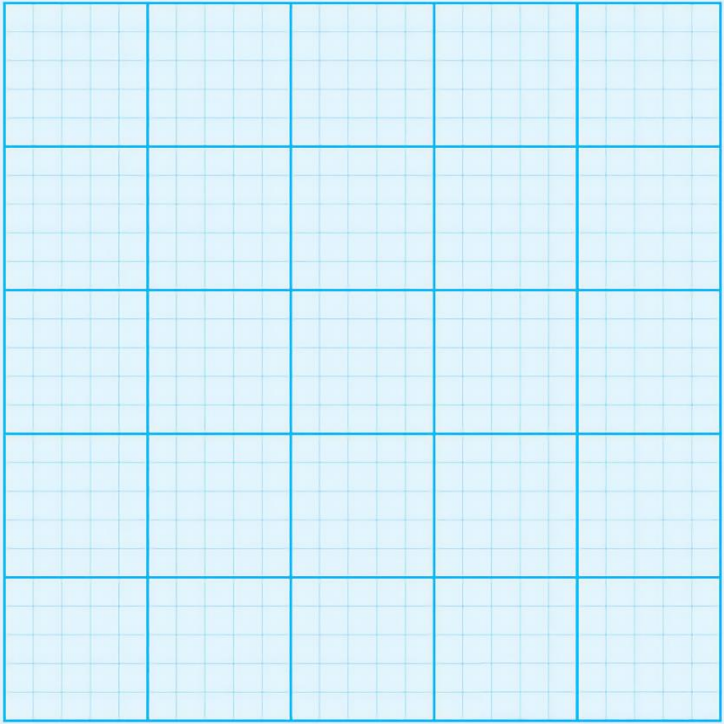
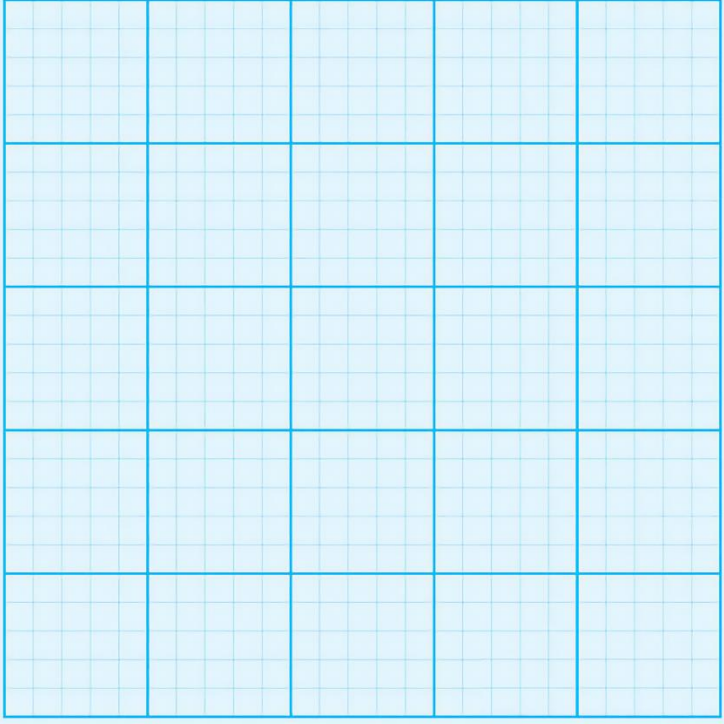
	$v_{10} = \quad \text{mol L}^{-1} \text{ s}^{-1}$
	$v_{20} = \quad \text{mol L}^{-1} \text{ s}^{-1}$

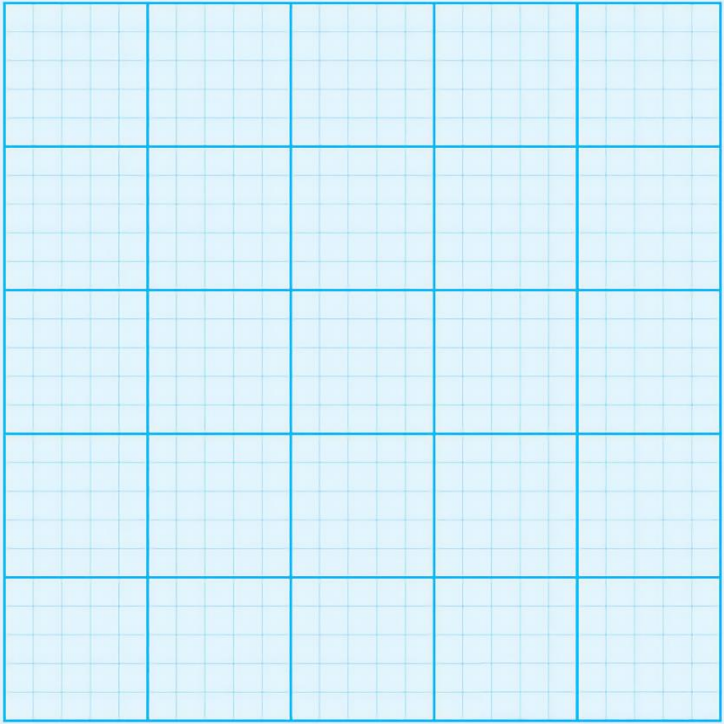

	$v_{30} = \quad \text{mol L}^{-1} \text{ s}^{-1}$
--	---

3. **Solve** the maximum velocity of the reaction ( $V_{\max}$ ) and the Michaelis constant ( $K_m$ ) of TYP under the given experimental condition using Lineweaver-Burk plot (or double reciprocal plot).

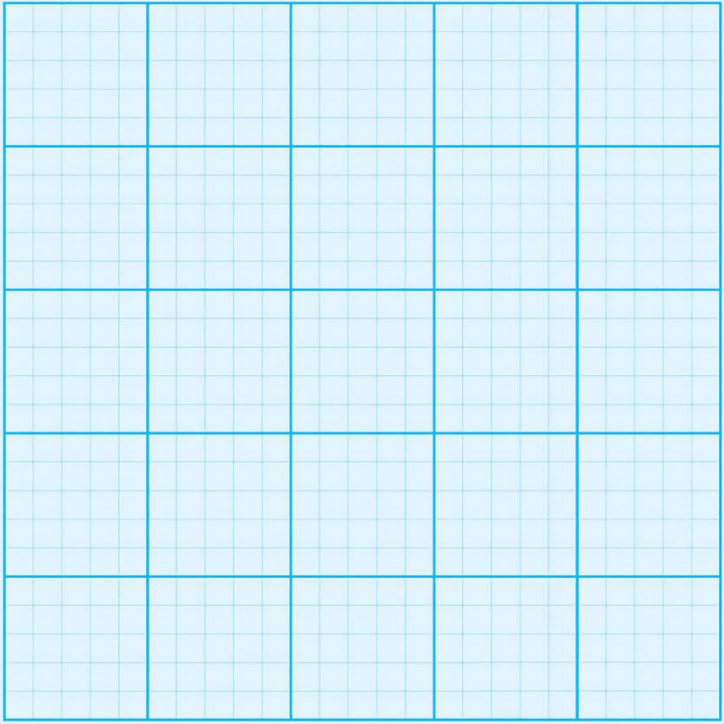
	$K_m = \quad \text{mol L}^{-1}$
	$V_{\max} = \quad \text{mol L}^{-1} \text{ s}^{-1}$

## P4. Synthesis of the Thermochromic Spin-crossover Materials

Most of the central ions of complexes have partially filled d orbitals. Under specific coordination field, the electrons may take two different arrangements of high and low spin. When the external conditions change, the electrons may process d-d transition, resulting in the change of spin state, that is, spin crossover (SC) phenomenon. The color, magnetic and other properties of the complexes will change.

For coordination compounds, ligand, coordination mode and solvent will affect the coordination field strength of central ions. When the electronic configuration of the central ion in an octahedral coordination field is  $d^4-d^7$ , and if the splitting energy  $\Delta$  is close to the pairwise energy  $P$ , the metal ion may exhibit SC behavior between high spin (HS) and low spin (LS) state following the changes in external conditions (such as temperature, pressure, optical excitation, etc.). The most studied SC complexes are  $[\text{Fe}(\text{II})(4\text{-R-trz})_3]_n^{2+}$  (4-R-trz = 4-substituted-1,2,4-triazole).

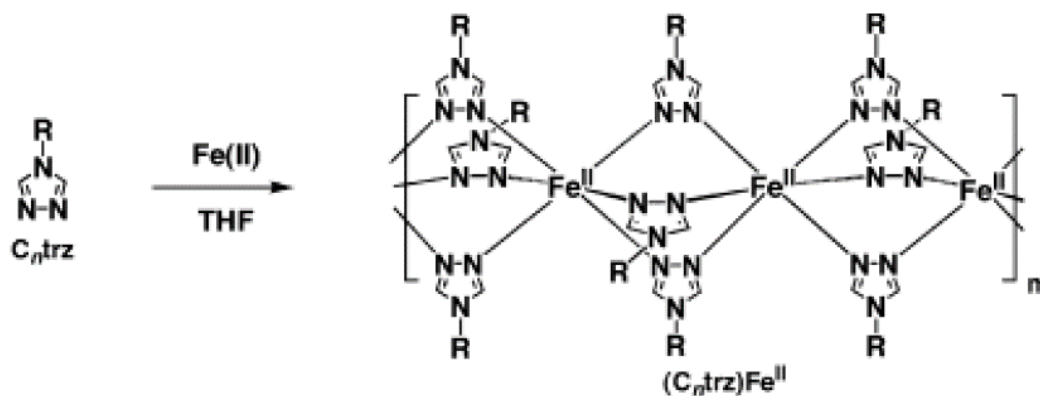

In these complexes, ferrous ions locate in an octahedral coordination field with a  $3d^6$  electronic configuration (see below), which meets the conditions for SC. The d-d transition can arise in both forms, which leads to weak absorptions at a specific wavelength (because they have spin allowed and symmetric forbidden transition). Taking  $\{[\text{Fe}(\text{htz})_3](\text{BF}_4)_2\}_n$  as an example, the complex is at LS state below 345 K with a certain absorption at 510 nm. Above this temperature, it is at HS state with absorption in the infrared region. The transformation process is highly sensitive toward temperature response with good reproducibility.

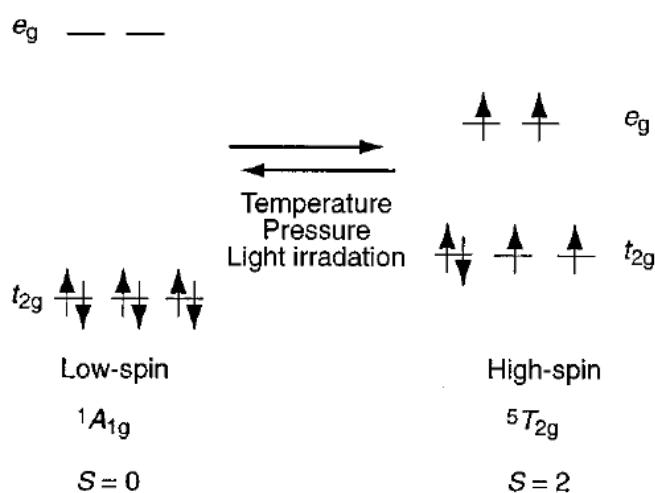

## Chemicals

Substance	Name	State	GHS hazard statements
$\text{Fe}(\text{ClO}_4)_2 \cdot x\text{H}_2\text{O}$	Iron(II) perchlorate hydrate	Solid	H272, H315, H319, H335
$\text{Fe}(\text{BF}_4)_2 \cdot 6\text{H}_2\text{O}$	Iron(II) tetrafluoroborate	Solid	H302, H312, H314, H318, H332
$\text{C}_6\text{H}_8\text{O}_6$	L-ascorbic acid	Solid	Non-hazardous
$\text{C}_2\text{H}_3\text{N}_3$	1H-1,2,4-triazole	Solid	H302, H319
$\text{C}_2\text{H}_6\text{O}$	Absolute ethanol	Liquid	H225, H319

## Glassware and equipment

- 1 Balance
- 1 Magnetic stirrer with stir bars and heater
- 1 Water pump
- 1 Buchner Funnel
- 1 Filtering flask
- 1 Oven
- 1 Beaker (50 mL)
- 1 Pipette (1000  $\mu\text{L}$ )
- 1 Dropper (2 mL)
- 1 Glass rod
- 2 glass tubes (5 mL)
- 1 Water bath with a thermometer

## Other materials

- Filter paper
- Weighing paper

## Experiment procedure

### I. Synthesis of $\{[\text{Fe}(\text{Htrz})_3](\text{BF}_4)_2\}_n$

1. Add 0.88 g  $\text{Fe}(\text{BF}_4)_2 \cdot 6\text{H}_2\text{O}$  and 0.54 g 1H-1,2,4-triazole to a beaker (50 mL).
2. Add 0.05 g ascorbic acid to prevent oxidation of Fe(II).
3. Add 25 mL absolute ethanol and stir for 15 min under room temperature.
4. Collect the solid by suction filtration and wash the product with absolute ethanol (2 mL  $\times$  2).
5. Dry the product in oven at 50  $^\circ\text{C}$  for 15 min.

### II. Synthesis of $\{[\text{Fe}(\text{Htrz})_3](\text{ClO}_4)_2\}_n$

6. Add 0.89 g  $\text{Fe}(\text{ClO}_4)_2 \cdot x\text{H}_2\text{O}$  and 0.54 g 1H-1,2,4-triazole to a beaker (50 mL).
7. Add 0.05 g ascorbic acid to prevent oxidation of Fe(II).
8. Add 25 mL absolute ethanol and stir for 15 min under room temperature.
9. Collect the solid by suction filtration and wash the product with absolute ethanol (2 mL  $\times$  2).
10. Dry the product by oven at 50  $^\circ\text{C}$  for 15 min.

### III. Verification of spin conversion properties of two complexes

11. Take a small amount of powder of  $\{[\text{Fe}(\text{Htrz})_3](\text{BF}_4)_2\}_n$  and  $\{[\text{Fe}(\text{Htrz})_3](\text{ClO}_4)_2\}_n$  to two tubes separately.

- Heat tubes in the water bath. Observe the experimental phenomenon and record the temperature when the color of the product in the tube changes.
- Take the tubes out of the water bath and cool down the tubes under room temperature. Observe the experimental phenomenon and record the temperature when the color of the product in the tube changes.

## Results

Complex	Yield	Complex color at room temperature	Spin state of Fe <sup>2+</sup> at room temperature	SC temperature
{[Fe(Htrz) <sub>3</sub> ](BF <sub>4</sub> ) <sub>2</sub> } <sub>n</sub>				
{[Fe(Htrz) <sub>3</sub> ](ClO <sub>4</sub> ) <sub>2</sub> } <sub>n</sub>				

## Questions

- Write** the reaction equation for procedure I and calculate the yield.
- Write** the reaction equation for procedure II and calculate the yield.
- According to the experiment results, the calculated magnetic moment ( $\mu$ ) of complexes {[Fe(Htrz)<sub>3</sub>](BF<sub>4</sub>)<sub>2</sub>}<sub>n</sub> and {[Fe(Htrz)<sub>3</sub>](ClO<sub>4</sub>)<sub>2</sub>}<sub>n</sub> at room temperature **should be** (            ), respectively.  
 (a) 0, 0            (b) 0, 4.90            (c) 3.87, 3.87            (d) 4.90, 4.90

## P5. The Extraction of Indigo from Radix Isatidis and its Synthesis for Application in Tie-dyeing

Indigo is one of the earliest fabric dyes used by people and now is a common blue dye used widely all over the world. The classic denim blue comes from the dye indigo. In ancient times, people extracted and processed natural indigo from a variety of plants such as radix isatidis, polygonum indica, isatis indigotica, wood blue, horse blue, etc. However, large-scale use of indigo dye is limited by its high price. In 1879, Baeyer developed a method for synthesizing indigo, which was called the Baeyer-Drewsen indigo synthesis method.

As a commonly used Chinese medicinal material, radix isatidis has the effects of clearing away heat, detoxifying, cooling blood and relieving pharynx. At the same time, it is also a dye with a long history and a wide range of applications. Its main dyeing substance is indigo, which is a blue powder and slightly soluble in water or alcohol. The molecular formula is C<sub>16</sub>H<sub>10</sub>N<sub>2</sub>O<sub>2</sub>, and the melting point is 390-392°C.

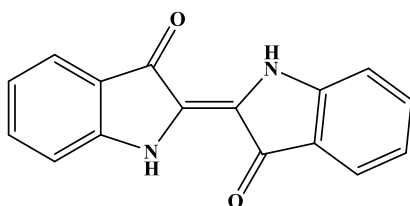

The existing form of indigo in radix isatidis is indigo glucoside. Indigo is formed by the condensation of two molecules of indigo glucoside. Indigo glucoside is easily soluble in ethanol and water, but indigo is slightly soluble.

### Chemicals

Substance	Name	State	GHS hazard statements
CH <sub>4</sub> N <sub>2</sub> O <sub>2</sub> S	Thiourea dioxide	Solid	H251, H302, H315, H319, H335
CaO	Calcium oxide	Solid	H315, H318
NaOH	Sodium hydroxide	Solid	H290, H314, H318
NaCl	Sodium chloride	Solid	Non-hazardous
NaOH	Sodium hydroxide (3 mol L <sup>-1</sup> )	Aqueous solution	H290, H314, H318
C <sub>2</sub> H <sub>5</sub> OH	Ethanol (75%)	Aqueous solution	H225, H319
C <sub>2</sub> H <sub>5</sub> OH	Ethanol (95%)	Aqueous solution	H225, H319
H <sub>2</sub> O <sub>2</sub>	Hydrogen peroxide (30%)	Aqueous solution	H302, H315, H318, H333, H335
C <sub>3</sub> H <sub>7</sub> NO	N,N-dimethylformamide (DMF)	Liquid	H226, H303, H312, H319, H332
C <sub>7</sub> H <sub>5</sub> NO <sub>3</sub>	2-nitrobenzaldehyde	Solid	H302, H315, H319, H335
C <sub>3</sub> H <sub>6</sub> O	Acetone	Liquid	H225, H316, H319, H336
CHCl <sub>3</sub>	Trichloromethane	Liquid	H302, H315, H319, H331, H351
C <sub>16</sub> H <sub>10</sub> N <sub>2</sub> O <sub>2</sub>	Indigo	Solid	H335
H <sub>2</sub> O	Distilled water	Liquid	Non-hazardous

### Glassware and equipment

- 1 Balance (0.1 g)
- 3 Glass beakers (250 mL × 2, 100 mL)
- 3 Graduated cylinders (100 mL, 50 mL, 10 mL)
- 1 Erlenmeyer flask (50 mL)
- 1 Mortar
- 1 Glass rod
- 1 Buchner funnel
- 1 Suction flask
- 1 Glass Pasteur pipette
- 1 Volumetric flask, 10 mL (1)
- 1 Spectrophotometer
- 1 Quartz cell
- 1 Scissor
- 1 Tweezers

### Other materials

- pH test papers

TLC plates & capillaries & chamber  
Weighing papers  
Filter papers  
Spatula  
Cotton

Radix isatidis powder or branches and leaves (Alternative plants: polygonum indica, isatis indigotica, wood blue and horse blue)

### Experimental procedure

**Cautions:** (a) The extraction experiment needs to be soaked for a certain time and must not be left unattended. (b) Use gloves! Hydrogen peroxide has strong oxidizing properties, if skin is stained, rinse immediately with water. (c) After adding thiourea dioxide, the dye liquor has strong alkaline and strong reducing properties. Beware of burns!

#### I. Extraction indigo from radix isatidis

1. Add 5.0 g of radix isatidis powder (or 15.0 g of fresh radix isatidis branches and leaves (cut and grounded before) to a 250 mL beaker.
2. Add 100 mL of ethanol (75%) and soak for 30 min. (Note: During this period, you can perform the operation of tying flowers and perform this step in the dyeing experiment, as shown below. The fabric used for tying flowers should be cotton.)



3. Add 50 mL of distilled water and 2.0 g of calcium oxide to the beaker and stir well.
4. Add NaOH solution (3 mol L<sup>-1</sup>) dropwise to adjust pH to 9-11 and stay for 0.5 min.
5. Add 30% hydrogen peroxide solution dropwise to form an indigo blue precipitate after a large amount of blue substance appears in the solution.
6. The mother liquor is reserved for dyeing. Collect dark blue solid by suction filtration and wash with ethanol (95%, 2 mL × 3) and water (2 mL × 3) sequentially.
7. Dry in an oven at 80 °C for 1 h to obtain indigo powder with high purity.

#### II. Synthesis of indigo

8. Add 0.1 g of 2-nitrobenzaldehyde and 2 mL of acetone to a 50 mL Erlenmeyer flask and shake to dissolve the solid.
9. Add 25 drops (about 1.25 mL) of distilled water and 15 drops (about 0.75 mL) of sodium hydroxide (3 mol L<sup>-1</sup>) solution slowly to form dark indigo precipitate. Continue to react for about 10 min.
10. Collect the crystals by suction filtration and wash the crystals with distilled water until the filtrate is colorless.
11. Wash the crystals with ethanol (95%, 2 mL × 3).

### III. Analysis of indigo

12. TLC inspection: Expanding agent is CHCl<sub>3</sub>: C<sub>2</sub>H<sub>5</sub>OH = 9:1 (V/V). The R<sub>f</sub> value, dot shape and color of the sample are the same as the standard sample as shown below.

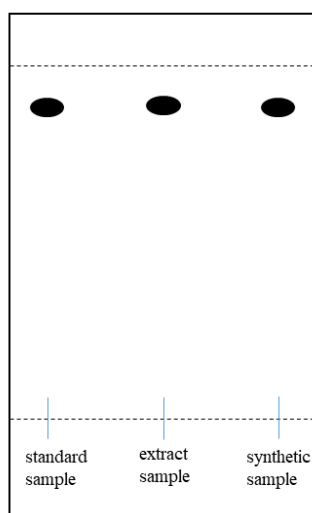

### IV. Dyeing with the indigo

13. Add 0.70 g of thiourea dioxide, 0.70 g of sodium hydroxide and 0.10 g of sodium chloride to the mother liquor of radix isatidis and stir evenly.
14. Put the patterned cloth (can be designed by yourself) into the solution and soak for 5 min.
15. Take the cloth out and transfer to 40 mL 30% hydrogen peroxide solution in a 100 mL beaker.
16. Take the cloth out and wash off the floating color with laundry detergent after soaking for 5 min.
17. Dry under room temperature to obtain the finished products with different patterns as shown below.

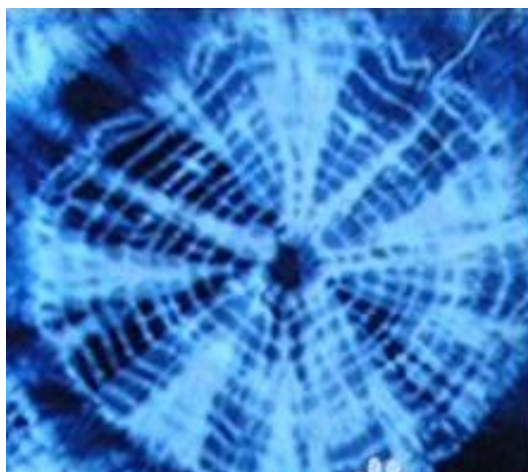

### Questions

1. Thiourea dioxide is firstly added in the dyeing process to increase the solubility of indigo in water and the firmness of binding fabric fibers, the indigo becomes indigo white, and its structure **is** ( ); then after NaOH is added, its structure **becomes** ( ) and after NaCl is added, its structure **is** ( ). Finally soaked in H<sub>2</sub>O<sub>2</sub> solution, the structure **is** ( ).

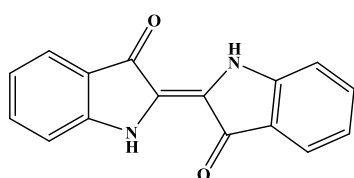

**A**

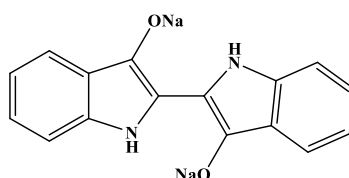

**B**

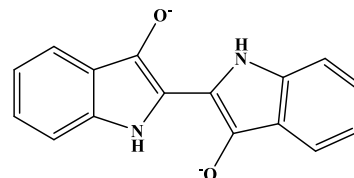

**C**

2. **Write** the chemical reaction happening during indigo dyeing.

3. The order of solubility of **A**, **B**, **C** in water **is** ( ) < ( ) < ( ).

## P6. Synthesis of Carbon Dots from Kitchen Wastes

Carbon dots is a new type of spherical or quasi-spherical quantum dots with size of 2-10 nm. It has low toxicity, good biocompatibility and water solubility and be widely applied in the fields of biomarker and bio-imaging.

Carbon dots are usually synthesized in the laboratory generally by hydrothermal method, electrochemical synthesis and so on. However, they can also be synthesized at home from peels or other kitchen wastes.

In this task, carbon dots can be synthesized from watermelon peels in the laboratory following the experiment procedure I and applied for detection of Fe(III) ions following the experiment procedure II. If it is impossible to complete the experiments in a professional laboratory because of epidemic situation, carbon dots would be still synthesized at home following the experiment procedure III.

### Chemicals



Substance	Name	State	GHS hazard statements
FeCl <sub>3</sub> · 6H <sub>2</sub> O	Fe(III) standard solution (0.01000 mol L <sup>-1</sup> )	Aqueous solution	H290, H303, H314, H318, H335
H <sub>2</sub> O	Distilled water	Liquid	Non-hazardous

### Glassware and equipment

- 1 Knife
- 1 Balance (0.1 g)
- 1 Enamel plate (24 × 18 cm)
- 1 Oven
- 1 Mortar
- 3 Beakers (100 mL)
- 1 Ultrasonic cleaner
- 3 Pipettes (1 mL, 5 mL, 20 mL) with pipette ball
- 1 Glass Buchner Filtering Funnel
- 2 Quartz cells
- 1 Ultraviolet light
- 1 Volumetric flask (250 mL)
- 1 Magnetic stirrer with stir bars
- 1 Fluorescence spectrometer
- 1 Juicer
- 1 Baking tray
- 1 Household oven
- 1 Banknote checking lamp

### Other materials

- Watermelon peels
- Filter membrane (0.22 μm)

### Experiment procedure

#### I. Synthesis of carbon dots in laboratory

1. After cleaning, weigh 300 g of watermelon peels, cut it into small pieces of about 1 cm and spread in an enamel square plate.
2. Place the plate in an oven and bake at 200 °C for 2 h to obtain the carbonized product of watermelon peel.
3. Grind 3 g of the carbonized product to powder in mortar after cooling down and transfer to a beaker (100 mL).
4. Add 30 mL distilled water in the beaker. Disperse the carbonized product in water ultrasonically for 10 min.
5. Put a 0.22 μm filter membrane in the Buchner filtering funnel, collect the filtrate by suction filtration.

- Take 1.00 mL filtrate to a volumetric flask (250 mL) and dilute to the mark with distilled water to obtain carbon dots standard solution, and marked it as **A**.
- Take a certain volume of A to a quartz cell and observe the fluorescence under ultraviolet light at 365 nm.

## II. Application of carbon dots for detection of Fe(III)

- Take 2.50 mL **A** to 2 beakers (100 mL) separately, add a certain volume of Fe(III) standard solution ( $0.01000 \text{ mol L}^{-1}$ ) and distilled water (see Table 1) to the beakers, stir for 10 min (600 rpm).
- Set the excitation wavelength of 365 nm, record the fluorescence spectra of 2 beakers and write the data in Table 1.

Table 1. Fluorescence of solutions with different concentrations of  $\text{Fe}^{3+}$

Volume of added Fe(III) standard solution ( $0.01000 \text{ mol L}^{-1}$ ) / mL	Volume of added distilled water / mL	Fluorescence intensity / a.u.
0.00	20.00	
20.00	0.00	

## III. Synthesis of carbon dots at home

- After cleaning, cut watermelon peel into small pieces and squeeze it with a squeezer.
- Take 30 g of residue and spread in a baking tray. Put the tray in a household oven and bake for 1 h at  $220 \text{ }^\circ\text{C}$  to obtain carbonized watermelon peels.
- After cooling down, grind the product to the fine powder by rolling pin or garlic pounder and transfer to a kitchen cup (1000 mL).
- Add about 300 mL drinking water, stir by spoon and stand for 20 min.
- Filter the solution by gauze (100 mesh) to obtain the filtrate.
- Take about 5 mL filtrate and dilute with about 120 mL drinking water. Observe the fluorescence under banknote checking lamp in the dark.

## Questions

- In this experiment, the possible substrates of carbon dots **are**: (**Multiple Choice**)
  - Glucose
  - Protein
  - Cellulose
  - Starch
- In this task, the wavelength of the emission is shorter than that of the irradiation.
  - Correct
  - Wrong
  - Uncertain

## P7. Synthesis and Purity Analysis of N-acetylphenylalanine in Aqueous Phase

This task contains two parts: synthesis of organic compound N-acetylphenylalanine by phenylalanine and acetic anhydride in alkaline solution; purity analysis of the product by acid-base titration.

### Chemicals

Substance	Name	State	GHS hazard statements
$C_6H_5CH_2CH(NH_2)CO_2H$	Phenylalanine	Solid	Non-hazardous
$(CH_3CO)_2O$	Acetic anhydride (provided by mentor)	Liquid	H226, H302, H314, H318, H332, H335
HCl	Hydrogen chloride acid (6 mol L <sup>-1</sup> )	Aqueous solution	H290, H314, H318
HCl	Hydrogen chloride acid (2 mol L <sup>-1</sup> )	Aqueous solution	H290, H314, H318
NaOH	Sodium hydroxide (1.0 mol L <sup>-1</sup> )	Aqueous solution	H290, H314, H318
$C_8H_5KO_4 \cdot 2H_2O$	Potassium hydrogen phthalate	Solid	Non-hazardous
$C_2H_6O$	Absolute ethanol	Liquid	H225, H316, H319
$C_{20}H_{14}O_4$	Phenolphthalein (PP, 0.2% in ethanol)	Ethanol solution	H225, H319
$CH_2Cl_2$	Dichloromethane	Liquid	H315, H319, H336, H351
N/A	Petroleum ether	Liquid	H225, H304, H315
$CH_3COOC_2H_5$	Ethyl acetate	Liquid	H225, H319, H333, H336
$H_2O$	Distilled water	Liquid	Non-hazardous

### Glassware and equipment

- 1 Round bottom flask (100 mL)
- 1 Magnetic stirrer & stir bar
- 1 Condenser
- 1 Beaker (100 mL)
- 1 Glass rod
- 1 Buchner funnel
- 1 Syringe (5 mL) with stainless steel needle
- 1 Reagent bottle (500 mL)
- 1 Graduated cylinder (100 mL)
- 3 Erlenmeyer flasks (250 mL)
- 1 Burette (50 mL) with Teflon plug
- 1 Laboratory stand with burette clamp
- 2 Weighing bottles (25 × 25 mm)

1 Ice water bath

### Other materials

TLC plates & capillaries & chamber

pH test papers

### Experiment procedure

#### I. Synthesis of N-acetylphenylalanine

1. Add 1.0 g phenylalanine and 25.0 mL NaOH solution ( $1.0 \text{ mol L}^{-1}$ ) to a round bottom flask (100 mL). Start to stir until phenylalanine dissolve completely.
2. Add 2.0 mL acetic anhydride by syringe (**This step should be carried out by mentor!**) and reflux for 40 min under stirring vigorously (Note: The temperature will rise during this step. What should be considered when taking acetic anhydride? Acetic anhydride is flammable and corrosive. Do not contact skin or eyes to prevent damage and tear inducing.)
3. After cooling down to room temperature, pour the solution to a beaker (100 mL), acidify by addition of HCl solution ( $6 \text{ mol L}^{-1}$ ) dropwise under stirring by glass rod till the pH value is 1-2 (tested by pH test paper). The crystals will be precipitated from the solution. (Where should the pH test paper be placed when measuring pH? The test paper should be placed on a surface dish when measuring pH.)
4. Put the beaker in an ice-water bath till the crystals precipitate completely. (How to solve the problem without precipitated crystals? Shake the flask violently to precipitate the crystals.)
5. Filter under reduced pressure by Buchner funnel, wash the product with HCl solution ( $2 \text{ mol L}^{-1}$ ,  $5 \text{ mL} \times 3$ ). Identify the product by TLC with petroleum ether and ethyl acetate (1:1) as developing agent in silica gel G plat (take a little product and dissolve it in dichloromethane (about 1%)). (Why add adhesive when preparing silica gel plate? to increase its mechanical strength.)
6. Dry in an oven at  $100 \text{ }^\circ\text{C}$  for 30 min and weigh to calculate the yield. (What temperature should not exceed when drying products in the oven? The temperature of drying products in the oven should not exceed  $100 \text{ }^\circ\text{C}$ . The yield is equal to the actual yield of product divided by the theoretical yield.)

#### II. Calibration of NaOH standard solution

7. Take 25 mL NaOH solution ( $1 \text{ mol L}^{-1}$ ) and 475 mL distilled water to a reagent bottle (500 mL) and shake the bottle well before use.
8. Weigh 0.2-0.3 g potassium hydrogen phthalate accurately by decrement method to an Erlenmeyer flask (250 mL) and add 30 mL distilled water.
9. After complete dissolution of potassium hydrogen phthalate, add 2 drops PP, titrate with NaOH standard solution till the ending-point. Repeat the titration 3 times. Calculate the concentration of NaOH standard solution.

### III. Purity analysis of product

10. Weigh 0.20-0.25 g product accurately by decrement method to an Erlenmeyer flask (250 mL) and add 20 mL absolute ethanol to dissolve. Add 30 mL distilled water and shake well.
11. Add 2 drops of PP and titrate with NaOH standard solution till the ending-point. Repeat the titration 3 times. Calculate the purity of the product.

### Questions

1. **What** is the purposes of synthesis of N-acetylphenylalanine in peptides and proteins synthesis?
2. In this experiment, **why** was PP used as indicator instead of litmus?
3. **Why** was the end-point at the moment that pink color appears and did not fade for 30 seconds?

## P8. Reaction Types and Chemical Logic (Virtual Experiment)

The purpose of this virtual experiment is to help students understand how scientists collect physical data, organize the data and reach logical conclusions. First you will learn a set of chemical reactions among inorganic acids, bases and salts which are commonly used in a chemical laboratory. A subset of the same solutions will then be assigned randomly as “unknowns” for students to identify. Students need to make careful observations and recording, and then make a chemical logical judgment on unknown compounds.

### Experiment procedure

1. Log on: <https://prj15.xnfz.cmet.ustc.edu.cn/> (username: test001, password: 123456)

(Note: Android mobile phone users can scan the QR code on the log-on page, download the app and complete the experiment on the mobile phone.)

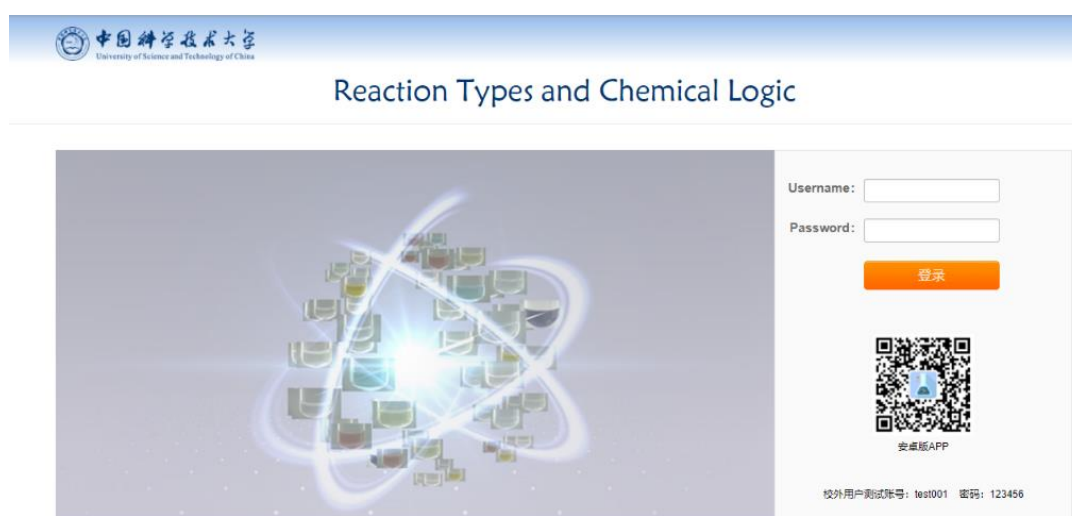

2. Click “Matrix of Known Reagents” in Procedure A in the main page and learn the color and pH value of common acids, bases, salts as well as the reactions between them. If you need to record the reaction phenomenon of each compound, click "observation table"

template" in the main page to download the table of observations for known agents.

## Reaction Types and Chemical Logic

[Purpose of the Experiment](#) 实验目的

[Background](#) 实验背景

[Experimental Procedure](#) 实验步骤

A. [Observation of Reactions Between Known Solutions](#) 已知化合物之间的化学反应

[Matrix of Known Reagents](#) 已知化合物反应矩阵

[Observation Table Template](#) 反应现象观察表

B. [Identification of a Set of Unknowns](#) 未知化合物的鉴别

[Start Quiz](#) 考试

C. [Lab Report Form](#) 实验报告单

[Video Demonstration](#) 实验操作演示

[Copyright](#) 版权

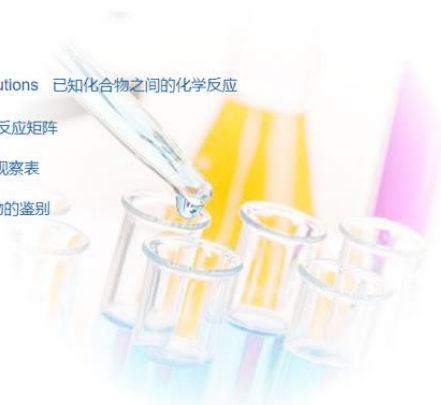

- Click "Start Quiz" in Procedure B, a  $7 \times 7$  unknown set will be presented randomly. The unknowns are identified by the letters A through G. Clicking on the buttons allows you to observe phenomenon of the reactions between the unknowns. Clicking on a letter around the edge will give a picture of the pure solution plus a spotted piece of pH paper.
- Click "Identify" to fill your determination of the identity of each unknown on the answer sheet. Submit your answer online, then you will get your score immediately.

### MATRIX OF UNKNOWN REAGENTS

Set Number: 4251

X	A	B	C	D	E	F	G
A	X	B+A	C+A	D+A	E+A	F+A	G+A
B	A+B	X	C+B	D+B	E+B	F+B	G+B
C	A+C	B+C	X	D+C	E+C	F+C	G+C
D	A+D	B+D	C+D	X	E+D	F+D	G+D
E	A+E	B+E	C+E	D+E	X	F+E	G+E
F	A+F	B+F	C+F	D+F	E+F	X	G+F
G	A+G	B+G	C+G	D+G	E+G	F+G	X

Countdown : 0h-25m-46s

 Identify

## P9. Properties and Identification of Heavy Metal Ions (Virtual Experiment)

Heavy metals and their compounds have always been the research focuses in the fields of medicine and health, materials, energy, modern industry and so on. Since most heavy metal elements and compounds are toxic, the identification of heavy metal ions is an important issue to our daily life.

The outer d and f electronic orbitals of heavy metal elements usually have unpaired electrons, which can be excited by visible light. Therefore, most heavy metal ions are colorful. Companying with their chemical reactions, there are obvious observable changes in solutions. Taking advantage of this quality, heavy metal ions can be identified through observing the changes happened in their chemical reactions. This virtual experiment permits students a clear view of what happens in each reaction, help students master the chemical properties and identification of different heavy metal ions, while does no harm to students' health and environment as well.

### Experiment procedure

1. Log on: <https://prj16.xnfz.cmet.ustc.edu.cn/> (username: test001, password: 123456)

(Note: Android mobile phone users can scan the QR code on the log-on page, download the app and complete the experiment on the mobile phone.)



2. Click "Matrix of Known Reagents" in Procedure A in the main page to learn the properties of heavy metal ions and the reactions between them. If you need to record the reaction phenomenon of each ion, click "observation table template" in the main page to download the table of observations for known agents.

## Properties and Identification of Heavy Metal Ions

[Purpose of the Experiment](#) 实验目的

[Background](#) 实验背景

[Experimental Procedure](#) 实验步骤

A. [Observation of Reactions Between Known Solutions](#) 带金属离子的化学性质学习

[Matrix of Known Reagents](#) 带金属离子反应试剂

[Observation Table Template](#) 反应现象观察表

B. [Identification of a Set of Unknowns](#) 未知重金属离子的鉴别

[Start Quiz](#) 考试

C. [Lab Report Form](#) 实验报告单

D. [Multiple-Choice Questions](#) 课后习题

[Demonstration](#) 实验操作演示

[Supplementary Materials](#) 教辅材料

[Copyright](#) 版权



- Click “Start Quiz” in Procedure B, a  $5 \times 10$  unknown set will be presented randomly. The unknowns are identified by the letters A through O. Clicking on the buttons allows you to observe phenomenon of the reactions between the unknowns. Clicking on a letter around the edge will give a picture of the pure solution.

### MATRIX OF UNKNOWN REAGENTS

Set Number: 5109

X	A	B	C	D	E
F	F+A	F+B	F+C	F+D	F+E
G	G+A	G+B	G+C	G+D	G+E
H	H+A	H+B	H+C	H+D	H+E
I	I+A	I+B	I+C	I+D	I+E
J	J+A	J+B	J+C	J+D	J+E
K	K+A	K+B	K+C	K+D	K+E
L	L+A	L+B	L+C	L+D	L+E
M	M+A	M+B	M+C	M+D	M+E
N	N+A	N+B	N+C	N+D	N+E
O	O+A	O+B	O+C	O+D	O+E

Countdown : 1h-59m-6s

Identify

- Click “Identify” to fill your determination of the identity of each unknown on the answer sheet. Submit your answer online, then you will get your score immediately.
- Complete “Multiple- Choice Questions” in procedure D in the main page.