

19th – 29th July 2018
Bratislava, SLOVAKIA
Prague, CZECH REPUBLIC

www.50icho.eu

PRACTICAL PROBLEMS

Country:	
Name as in passport:	
Student code:	
Language:	



50th IChO 2018

International Chemistry Olympiad
SLOVAKIA & CZECH REPUBLIC

BACK TO WHERE IT ALL BEGAN



General instructions

- This practical exam booklet contains 26 pages.
- Before the start of the exam, you will have additional 15 minutes to read the exam booklet. **Do not work, write or calculate during this time, otherwise you will be disqualified.**
- You may begin working as soon as the **Start** command is given.
- You have **5 hours** to complete the exam.
- You may work on the tasks in any order, but starting with Problem P1 is recommended.
- All results and answers must be clearly written **in pen in their respective designed areas** on the exam papers. Answers written outside the answer boxes will not be graded.
- Do not use a pencil or a marker to write the answers. Use only the pen and calculator provided.
- You were provided with 3 sheets of scratch paper. If you need more, use the backside of the exam sheets. Remember that **nothing outside the designed areas will be graded.**
- **The official English version** of the exam booklet is available upon request and serves for clarification only.
- If you need to leave the laboratory (to use the toilet or have a drink or snack), tell your lab assistant. He or she will come to accompany you.
- You must **follow the safety rules** given in the IChO regulations. If you break the safety rules, you will receive only one warning from the lab assistant. Any safety rule violations after the first warning will result in your dismissal from the laboratory and 0 marks for the entire practical examination.
- Chemicals and labware, unless otherwise noted, will be refilled or replaced without penalty only for the first item. Each further incident will result in the deduction of 1 point from your 40 practical exam points.
- The lab assistant will announce a 30 minute warning before the **Stop** command.
- You must stop your work immediately when the **Stop** command is announced. Failure to stop working or writing by one minute or longer will lead to nullification of your practical exam.
- After the **Stop** command has been given, a lab assistant will come to sign your answer sheet. After both the assistant and you sign, place this exam booklet back in the exam envelope and submit it for grading together with your products and TLC plates.



Lab rules and safety

- You must wear a lab coat and keep it buttoned up. Footwear must completely cover the foot and heel.
- Always wear safety glasses or prescription glasses when working in the lab. Do not wear contact lenses.
- Do not eat or drink in the lab. Chewing gums are not allowed.
- Work only in the designed area. Keep your work area and the common work areas tidy.
- No unauthorised experiments are allowed. No modification of the experiments is allowed.
- Do not pipette with your mouth. Always use a bulb pipette filler.
- Clean up spills and broken glassware immediately from both the bench and the floor.
- All waste must be properly discarded to prevent contamination or injury. Non-hazardous water soluble/miscible lab waste is eligible for sink disposal. Other lab waste must be disposed of in a marked capped container.



Definition of GHS hazard statements

The GHS hazard statements (H-phrases) associated with the materials used are indicated in the problems. Their meanings are as follows.

Physical hazards

- H225 Highly flammable liquid and vapour.
- H226 Flammable liquid and vapour.
- H228 Flammable solid.
- H271 May cause fire or explosion; strong oxidiser.
- H272 May intensify fire; oxidiser.
- H290 May be corrosive to metals.

Health hazards

- H301 Toxic if swallowed.
- H302 Harmful if swallowed.
- H304 May be fatal if swallowed and enters airways.
- H311 Toxic in contact with skin.
- H312 Harmful in contact with skin.
- H314 Causes severe skin burns and eye damage.
- H315 Causes skin irritation.
- H317 May cause an allergic skin reaction.
- H318 Causes serious eye damage.
- H319 Causes serious eye irritation.
- H331 Toxic if inhaled.
- H332 Harmful if inhaled.
- H333 May be harmful if inhaled.
- H334 May cause allergy or asthma symptoms or breathing difficulties if inhaled.
- H335 May cause respiratory irritation.
- H336 May cause drowsiness or dizziness.
- H351 Suspected of causing cancer.
- H361 Suspected of damaging fertility or the unborn child.
- H371 May cause damage to organs.
- H372 Causes damage to organs through prolonged or repeated exposure.
- H373 May cause damage to organs through prolonged or repeated exposure.

Environmental hazards

- H400 Very toxic to aquatic life.
- H402 Harmful to aquatic life.
- H410 Very toxic to aquatic life with long lasting effects.
- H411 Toxic to aquatic life with long lasting effects.
- H412 Harmful to aquatic life with long lasting effects.



Chemicals

For all problems

Chemicals	Labelled as	GHS hazard statements ¹
Deionised water in: Wash bottle (bench) Plastic bottle (bench) Plastic canister (hood)	Water	Not hazardous

For Problem P1 (in white basket if not stated otherwise)

Chemicals	Labelled as	GHS hazard statements ¹
Ethanol , 100 cm ³ in wash bottle (bench)	Ethanol	H225, H319
2-Acetonaphthone : approx. 0.002 g in glass vial, standard for TLC 0.500 g in glass vial	Standard A	H302, H315, H319, H335, H411
	Reactant A	
2,4-Dinitrophenylhydrazine , containing 33% (w/w) of water, 0.300 g in glass vial	DNPH	H228, H302
Bleach solution, containing 4.7% of NaClO , 13.5 cm ³ in amber glass bottle	Bleach	H290, H314, H400
Ethyl acetate , 15 cm ³ in amber glass bottle	EtOAc	H225, H319, H336
Eluent for thin layer chromatography, hexanes/ethyl acetate 4:1 (v/v), 5 cm ³ in amber glass bottle	TLC eluent	H225, H304, H315, H336, H411 ²
5% Na₂CO₃ , aqueous solution, 20 cm ³ in plastic bottle	5% Na₂CO₃	H319
20% HCl , aqueous solution, 15 cm ³ in plastic bottle	20% HCl	H290, H314, H319, H335 and others

For Problem P2 (in green basket)

Chemicals	Labelled as	GHS hazard statements ¹
8 mmol dm ⁻³ luminol in 0.4 mol dm ⁻³ NaOH aqueous solution, 50 cm ³ in plastic bottle	Luminol in NaOH	H290, H315, H319
2.00 mmol dm ⁻³ CuSO₄ aqueous solution, 25 cm ³ in plastic bottle	Cu	Not hazardous
2.00 mol dm ⁻³ H₂O₂ aqueous solution, 12 cm ³ in small plastic bottle	H₂O₂ conc.	H302, H315, H318
0.100 mol dm ⁻³ cysteine hydrochloride aqueous solution, 12 cm ³ in small plastic bottle	Cys conc.	Not hazardous
Water , 50 cm ³ in plastic bottle	Water	Not hazardous

¹ See page 3 for the definition of the GHS hazard statements.

² The GHS hazard statements for hexanes.



For Problem P3 (in grey basket if not stated otherwise)

Chemicals	Labelled as	GHS hazard statements ¹
Sample of mineral water, 400 cm ³ in plastic bottle (bench)	Sample	Not hazardous
3 mol dm ⁻³ NH ₄ Cl / 3 mol dm ⁻³ NH ₃ solution in water, 15 cm ³ in plastic bottle	Buffer	H302, H319, H314, H400
NaCl, solid, 10 g in plastic bottle	NaCl	H319
Eriochrome black T, indicator mixture in plastic bottle	EBT	H319
Bromothymol blue, indicator solution in plastic bottle	BTB	H302, H315, H319
5.965 × 10 ⁻³ mol dm ⁻³ disodium ethylenediamine tetraacetate standard solution, 200 cm ³ in plastic bottle (bench)	EDTA	H302, H315, H319, H335
0.2660 mol dm ⁻³ NaOH standard solution, 250 cm ³ in plastic bottle (bench)	NaOH	H314
Strong acidic cation exchange resin, in H ⁺ form, 50 cm ³ of swollen material washed with deionised water in plastic bottle	Catex	H319

Equipment

For all problems (on shelf if not stated otherwise)

Shared equipment	Quantity
Paper wipes	1 box for 2–4
Waste paper basket (bench, close to sink)	1 for 4
Nitrile gloves (hood)	1 box for lab
Personal equipment	
Safety goggles	1
Pipette stand (bench)	1
Bulb pipette filler	1
Glass beaker, 100 cm ³ , containing: glass rod, plastic spoon, spatula, tweezers, marker, pencil, ruler	1 (each)

For Problem P1 (in white basket if not stated otherwise)

Shared equipment	Quantity
UV lamp (hood)	1 for up to 12
Vacuum source (plastic stopcock with vacuum hose, bench)	1 for 2
Personal equipment	
Hotplate stirrer (bench) with: Temperature probe, Crystallising dish, with metallic paperclip	1 (each)



Laboratory stand (bench) with: Clamp holder with small clamp Clamp holder with large clamp	1 (each)
Organic waste plastic bottle (bench)	1
Open metal ring	1
Round bottom flask, 50 cm ³ , with magnetic stir bar	1
Measuring cylinder, 10 cm ³	1
Reflux condenser	1
Separating funnel, 100 cm ³ , with stopper	1
Conical flask without ground joint, 50 cm ³	1
Conical flask without ground joint, 25 cm ³	1
Conical flask with ground joint, 50 cm ³	1
Glass funnel	1
Suction flask, 100 cm ³	1
Rubber adapter for filter funnel	1
Fritted (sintered) glass filter funnel, porosity S2 (white label)	1
Fritted (sintered) glass filter funnel, porosity S3 (orange-red label)	1
Glass beaker, 50 cm ³ , with Petri dish lid	1
Glass beaker, 150 cm ³	1
TLC graduated capillary spotter, 5 µl	3
Zippered bag with 5 pH indicator strips and 1 pH scale	1
Zippered bag with 2 TLC plates	1
Glass Pasteur pipette	4
Rubber bulb	1
Glass vial labelled Student code B for the product of the haloform reaction	1
Glass vial labelled Student code C for the product of the reaction with Brady's reagent	1

For Problem P2 (in green basket if not stated otherwise)

Personal equipment	Quantity
Stopwatch	1
Digital thermometer and card with its calibration constant	1
Volumetric flask, 50 cm ³	1
Bulb pipette, 5 cm ³ (bench, in pipette stand)	1
Graduated pipette, 5 cm ³ (bench, in pipette stand)	3
Graduated pipette, 1 cm ³ (bench, in pipette stand)	2
Plastic bottle labelled H₂O₂ dil. for diluted stock solution of H ₂ O ₂ , 50 cm ³	1
Plastic bottle labelled Cys dil. for diluted stock solution cysteine.HCl, 50 cm ³	1
Black plastic test tube, 15 cm ³	1



Capless centrifuge tube, 1.5 cm ³	1
Plastic beaker, 25 cm ³	1
Conical flask, 100 cm ³	1

For Problem P3 (in grey basket if not stated otherwise)

Personal equipment	Quantity
Laboratory stand (bench) with: White sheet of paper Burette clamp Burette, 25 cm ³	1 (each)
Bulb pipette, 50 cm ³ (bench, in pipette stand)	1
Bulb pipette, 10 cm ³ (bench, in pipette stand)	1
Glass funnel	1
Measuring cylinder, 5 cm ³	1
Titration flask (kind-of-round, flat bottomed flask), 250 cm ³	2
Conical flask, 250 cm ³	1
Fritted (sintered) glass filter funnel, porosity S1 (blue label)	1
Glass beaker, 100 cm ³	2
Glass beaker, 250 cm ³	1
Plastic Pasteur pipette, narrow stem, nongraduated	2
Plastic Pasteur pipette, thick stem, graduated	1
Zipped bag with 5 pH indicator strips and 1 pH scale	1
Zipped bag with 5 absorbing paper strips	1
Waste catex plastic bottle (bench)	1



Practical Problem P1	Question	1.1	1.2	yield	m.p.	Total
	14% of the total	Points	4	16	20	10
	Score					

Problem P1. Haloform reaction with bleach

Chemical test reactions have been developed as a means of identifying functional groups in unknown compounds. In this task, you will explore two examples of chemical test reactions on a preparatory scale, starting from (2-naphthyl)ethanone (**A**, 2-acetonaphthone):

- The haloform reaction is a transformation typical for methyl ketones which react with basic aqueous hypochlorite solution and provide a carboxylic acid (product **B**) and a haloform (trihalomethane).
- The reaction of Brady's reagent (acidic solution of 2,4-dinitrophenylhydrazine) with the carbonyl group of an aldehyde or ketone results in the formation of an orange hydrazone precipitate (product **C**).

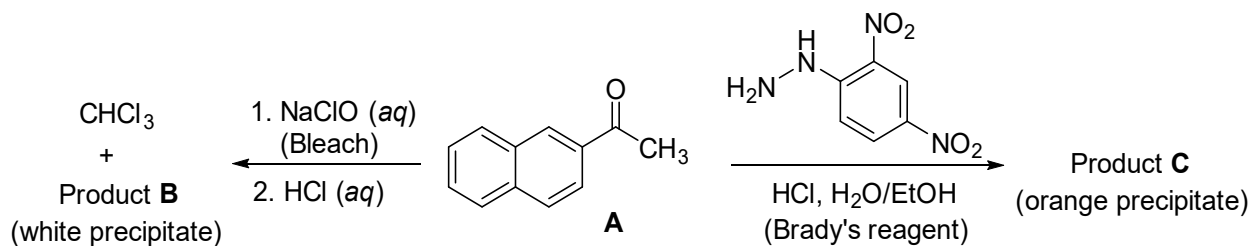

P1.1 Draw the structures of products **B** and **C**.

Product B	Product C
------------------	------------------

Notes:

- The total score will be based on the R_f values of compounds **A** and **B** calculated from the submitted TLC plate 1 and on the quality and quantity of the submitted products **B** and **C**.
- The quality of your products will be graded based on the TLC and melting points.
- The amount of the provided hypochlorite solution is not sufficient to convert all reactant **A** to product **B**. You will recover the residual reactant **A** by an acid-base extraction and isolate it after



the reaction with Brady's reagent as hydrazone **C**. The grading is based on the combined yield of products **B** and **C**.

Procedure

I. Haloform reaction

1. Turn on the stirrer and adjust the speed to 540 rpm. Immerse a temperature probe, resting the wire on the upper clamp, into the bath almost to the bottom and set the temperature to 80 °C.
2. Transfer the 0.500 g of 2-acetonaphthone from the vial labelled **Reactant A** into a 50 cm³ (teardrop-shaped) round bottomed flask that contains a magnetic stir bar. Measure 3 cm³ of ethanol (from the wash bottle) in a measuring cylinder and use it to transfer the remaining reactant **A** quantitatively into the round bottomed flask using a glass Pasteur pipette.
3. Place the round bottomed flask into the hot water bath. Attach an air reflux condenser (water connection is not needed) and secure it in the upper part by a loosely attached large clamp, as shown in Figure 1. Let compound **A** dissolve with stirring.

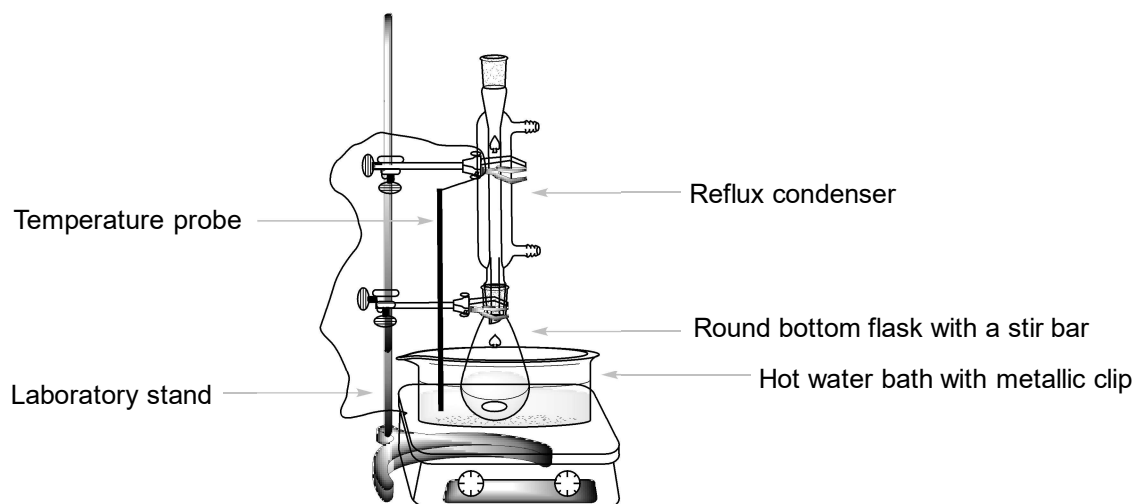

Figure 1. Setup for heating the reaction mixture in a water bath.

4. When the bath temperature reaches 75 °C, slowly add all the NaClO solution (**Bleach**) to the reaction mixture through the top opening of the condenser using the glass funnel. Heat the reaction mixture with stirring for 60 minutes between 75 and 80 °C.
5. Then turn off the heating of the hotplate stirrer. Loosen the upper clamp a bit and lift the reaction flask over the water bath. (*Caution!* Touch only the clamps, the flask is hot.) Allow the reaction mixture to cool down for 15 minutes.

II. Workup of the reaction mixture

1. Place a separating funnel into a metal ring and place a 50 cm³ conical flask without a ground joint under it. Using the glass funnel, pour the cooled reaction mixture into the separating funnel. Remove the stir bar from the glass funnel with tweezers. Measure 5 cm³ of ethyl acetate (**EtOAc**) and use it to rinse the reaction flask. Add the washings into the separating funnel using a glass Pasteur pipette.



- Perform the extraction. Allow the layers to separate. Collect the aqueous layer into the 50 cm³ conical flask without a ground joint. Using the glass funnel, pour the organic layer through the top neck into the 25 cm³ conical flask. Keep both phases!
- Using the glass funnel, pour the aqueous phase from the 50 cm³ conical flask back to the separating funnel. Measure another 5 cm³ of ethyl acetate and repeat the extraction (step No. II.2). Combine the organic phases together in the 25 cm³ conical flask. Keep both phases!
- Prepare your TLC plate. Check it before use. Unused damaged plates will be replaced upon request without penalty. Use a pencil to draw the start line and mark the positions for spotting the samples. Write number **1** in a circle and your student code on the top of the TLC plate as shown in Figure 2. Dissolve the given sample of 2-acetonaphthone in a vial (**Standard A**) in approx. 2 cm³ of ethanol (about 1 full glass Pasteur pipette). Mark three spot positions and label them **A**, **O1**, and **O2**. Spot 1 μl (one mark of the 5 μl capillary spotter) of standard **A** and the combined organic phase from step II.3 (**O1**). You will add spot **O2** later.

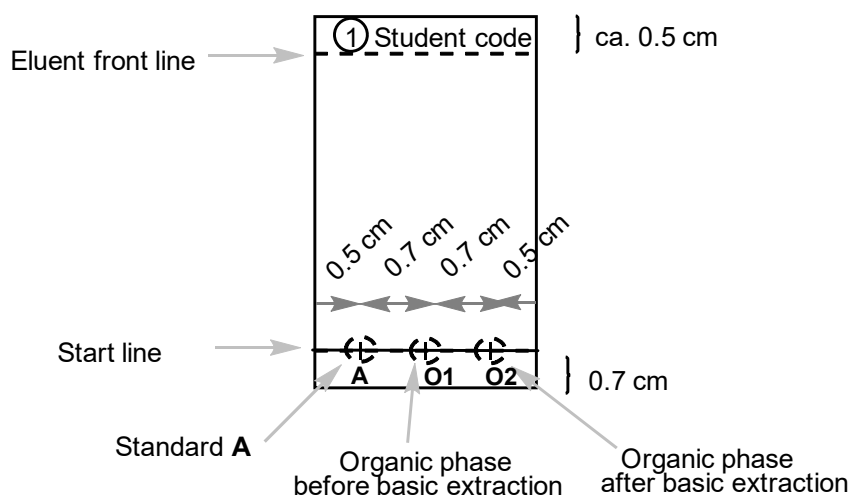

Figure 2. Instructions for the TLC plate preparation.

- Extract the combined organic phases twice with 5 cm³ of 5% Na₂CO₃ solution. Collect the aqueous phase into the same 50 cm³ conical flask without a ground joint containing the aqueous phase from the first extraction.
- Wash the organic phase in the separating funnel with 5 cm³ of deionised water. Add the aqueous phase to the combined aqueous extracts. Pour the organic layer (**O2**) through the top neck into a 50 cm³ ground-joint conical flask. Spot 1 μl of the solution **O2** on your TLC plate prepared in step II.4 (Plate 1).
- Perform a TLC analysis. Take a 50 cm³ beaker and load it with approx. 2 cm³ of the **TLC eluent**. Insert the TLC plate, cover the beaker with a Petri dish and let the eluent reach approximately 0.5 cm below the top edge of the plate. Using tweezers, take the TLC plate out, draw the eluent front line and let the plate air-dry. Place the TLC plate under the UV lamp in the hood. With a pencil, circle all the visualised spots and calculate the R_f values of reactant **A** and product **B**. Store your TLC plate in a plastic bag.

Note 1: Product **B** may tail on the TLC plate. Therefore, avoid excessive loading of the sample.



Note 2: In some cases, two additional spots of side products of a very low intensity may be seen in combined organic phase **O1** and **O2**. In this case, calculate the R_f value for the most intense spot(s).

Note 3: If the organic layer **O2** still contains both starting material **A** and product **B**, repeat the extraction with the Na_2CO_3 solution and water (steps No. II.5 and II.6). In this case, submit also another TLC plate after the repeated extraction (Plate 2), spotting only standard **A** and organic phase **O2**. Mark number **2** in a circle and your student code on the top of this TLC plate. Use a fresh batch of eluent to develop TLC Plate 2.

P1.2 Answer the following questions about your Plate(s). From Plate 1, calculate the R_f values of standard **A** and product **B**. Provide the results rounded to 2 decimal places.

Based on the TLC analysis, your organic layer O1 contains:		
	YES	NO
Starting material A	<input type="checkbox"/>	<input type="checkbox"/>
Product B	<input type="checkbox"/>	<input type="checkbox"/>
Based on the TLC analysis, your final organic layer O2 contains:		
	YES	NO
Starting material A	<input type="checkbox"/>	<input type="checkbox"/>
Product B	<input type="checkbox"/>	<input type="checkbox"/>
Calculation of the $R_f(\mathbf{A})$		
$R_f(\mathbf{A}) =$		
Calculation of the $R_f(\mathbf{B})$		
$R_f(\mathbf{B}) =$		

III. Reaction with Brady's reagent

Attention: Use gloves! Brady's reagent stains skin and all surfaces. Wash any spots immediately with ethanol! Change your gloves if necessary.

Preheat the water bath to 80 °C. Insert a magnetic stir bar into the 50 cm³ ground-joint conical flask containing the organic phase **O2** from step II.6 and add 0.300 g of 2,4-dinitrophenylhydrazine (**DNPH**). In a graduated cylinder, measure 10 cm³ of ethanol. Using a glass Pasteur pipette, rinse the glass vial with 5 × 2 cm³ of ethanol to transfer all of the **DNPH** into the conical flask. Place the conical flask into the hot water bath, attach a reflux condenser (similar setup as in Figure 1) pre-rinsed with ethanol. Through the top opening of the condenser, add 3 cm³ of 20% HCl using the glass funnel and stir the reaction mixture at 80 °C for 2 minutes. Fine orange crystals of product **C** start to form. Then turn off the heating of the hotplate stirrer. Lift the reaction flask above the water bath. (**Caution!** Touch only the clamps, the flask is hot.) Allow the reaction mixture to cool down for 15 min and then place it into a cold water bath (prepared by pouring cold tap water into a 150 cm³ beaker).



IV. Isolation of the products

1. Check the pH of the combined aqueous phase from step No. II.6. Acidify it by carefully adding 20% HCl solution, stirring the mixture with a glass rod (approx. 2 cm³ of the HCl solution should be required), to the final pH of 2 (check with pH indicator strips). A white precipitate of product **B** is formed.
2. Set up a vacuum filtration apparatus (Figure 3) using a glass fritted (sintered) funnel with porosity **S2** (with white label) and secure it to a laboratory stand with a small clamp. Connect the suction flask to the vacuum source. Pour the suspension of product **B** (step No. IV.1) into the fritted funnel, let the solid settle down, and then open the vacuum valve. *Caution:* notify the lab assistant before and after handling the valve! Wash the solid twice with 6 cm³ of deionised water, until the pH of the dropping filtrate is about 6. Let air suck through the precipitate for 5 minutes to pre-dry the product. Disconnect the vacuum source. Use the spatula to transfer white product B to a glass vial labelled **Student code B** and leave it uncovered on the bench to dry. Discard the filtrate to the sink drain and wash the suction flask.

Note: Be careful not to scratch the fritted glass into your product!

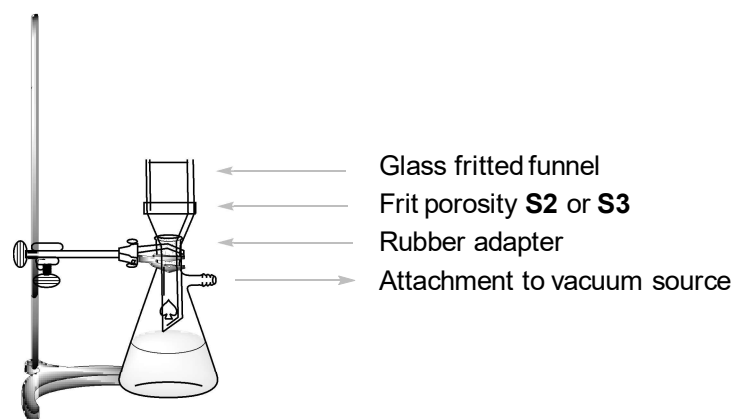

Figure 3. Setup for suction filtration.

3. Set up a vacuum filtration apparatus with a glass fritted funnel with porosity **S3** (with an orange-red label) similarly as in IV.2. Pour the suspension of product **C** (step No. III) into the fritted funnel, wait for a minute, and then open the vacuum valve. Do NOT stir or scratch the solid with the spatula while filtering and washing, otherwise the solid may go through the filter. Wash the precipitate three times with 5 cm³ of ethanol (15 cm³ in total) until neutral pH of the dropping filtrate is reached. Let air suck through the precipitate for 5 minutes. Disconnect the vacuum source. Use the spatula to transfer orange product C to a glass vial labelled **Student code C** and leave it uncovered on the bench to dry. Collect the filtrate into **Organic waste** bottle.

Note: If the product goes through the fritted funnel, filter the suspension once more. If the product still goes through, contact the lab assistant.

Your lab assistant will pick up following items and sign your answer sheet.

- Glass vials labelled **Student code B** and **C** with your products
- TLC plates in a zipped bag labelled with your **Student code**



Submitted items:

Product **B**

Product **C**

TLC Plate 1

TLC Plate 2 (optional)

Signatures:

Student

Lab assistant



Practical Problem P2	Question	2.1	2.2	2.3	2.4	2.5	2.6	Total
	Points	30	30	7	3	4	6	
13% of the total	Score							

Problem P2. A glowing clock reaction

Luminol is a well-known source of chemiluminescence. In the presence of a suitable redox catalyst, e.g. Cu^{2+} , it may react with oxidising agents, most commonly H_2O_2 , forming products in excited electronic states. These release the excess energy by the emission of blue light:

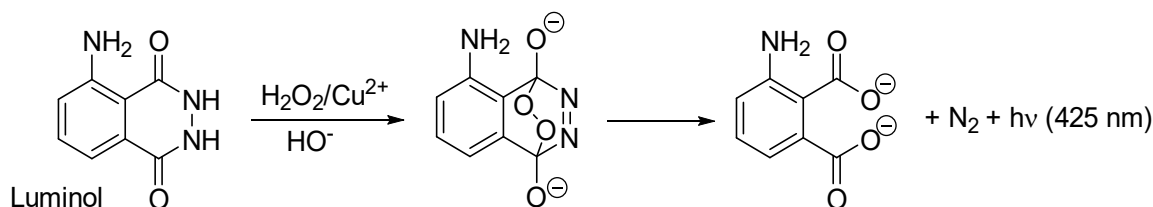

The procedure may be modified into a clock reaction, in which the light appears after a certain induction time. By adding cysteine, Cu(II) is reduced to Cu(I) and captured in a Cu(I) –cysteine complex that does not facilitate the luminol oxidation. However, the inhibition is only temporary. A cycle of reactions fuelled by H_2O_2 leads to the gradual oxidation of cysteine:

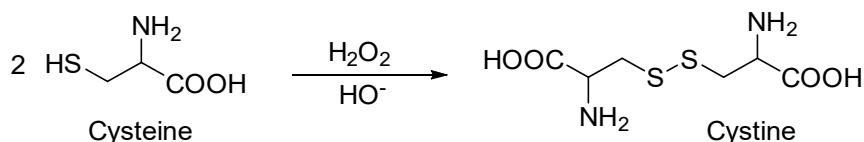

Eventually, all cysteine is consumed, Cu(I) is reoxidised to Cu(II) , and its catalytic activity is restored. This is indicated by a flash of blue chemiluminescence. The time it takes until the flash appears can be used to study the rates of the Cu -catalysed cysteine oxidation.

Procedure

Caution: Always keep all your solutions and pipettes away from hotplates!

Reasonable temperature changes are not a problem, because your results will be marked based on the actual reaction temperatures that you report. You will not lose any points if your data is recorded at various temperatures. However, you must avoid excessive heat, e.g. placing the solutions or the pipettes near a hotplate.

Note: Report all the values with the requested number of significant figures or decimal places. Excessive rounding may make it impossible to distinguish a correct answer from an incorrect one.

General structure of the experiment

In Part I, you will dilute two stock solutions that are provided as concentrates. In Part II, you will measure the reaction times of the clock reaction for two different concentration sets, as defined in the table below:



	Volume in the black test tube			In the centrifuge tube	
	Water	Luminol in NaOH	Cys dil.	Cu	H ₂ O ₂ dil.
Conc. set #1	3.00 cm ³	2.50 cm ³	3.30 cm ³	0.50 cm ³	0.70 cm ³
Conc. set #2	3.30 cm ³	2.50 cm ³	3.30 cm ³	0.50 cm ³	0.40 cm ³

It is recommended that before you start measuring the data to be graded, you should get familiar with the procedure in a trial run.

Because the reaction rate depends on temperature, you must record the actual temperatures in all replicates. The temperatures in the reaction mixtures should be measured IMMEDIATELY AFTER you have recorded the reaction time required to produce the blue flash.

In data evaluation, each temperature recorded from the thermometer's display must be corrected by summing it with the thermometer's calibration constant. This constant is printed on a piece of paper in the basket for Problem 2.

Then, each reaction time $t(x\text{ }^\circ\text{C})$ observed at $x\text{ }^\circ\text{C}$ (corrected) must be converted to the time $t(25\text{ }^\circ\text{C})$ that would be observed at $25\text{ }^\circ\text{C}$. This normalisation of reaction times to $25\text{ }^\circ\text{C}$ is a simple multiplication of $t(x\text{ }^\circ\text{C})$ with a normalisation coefficient $n_{x \rightarrow 25}$:

$$t(25\text{ }^\circ\text{C}) = n_{x \rightarrow 25} t(x\text{ }^\circ\text{C})$$

The values of the normalisation coefficients $n_{x \rightarrow 25}$ corresponding to various temperatures are listed in Table P2 at the end of this task.

I. Dilution of the concentrated stock solutions

Solutions of H₂O₂ (2.00 mol dm⁻³) and cysteine (0.100 mol dm⁻³) are provided as concentrates, labelled **H₂O₂ conc.** and **Cys conc.** Using the 5 cm³ bulb pipette and the 50 cm³ volumetric flask, dilute 5.00 cm³ of each to 50.00 cm³ with deionised water and store the diluted solution in the bottles labelled **H₂O₂ dil.** and **Cys dil.**

For measuring the solution volumes in the following steps, label one graduated pipette for each of the bottles. The 5 cm³ pipettes are for **Luminol in NaOH**, **Cys dil.**, and **Water**. The 1 cm³ pipettes are for **Cu** (2.00 mmol dm⁻³) and **H₂O₂ dil.**

II. The clock reaction procedure

Note: Read the entire Section II carefully before starting the experiment.

- Place the black test tube inside the conical flask serving as a stand. Using the assigned pipettes, charge the test tube with the prescribed volumes of **Water**, **Luminol in NaOH** and **Cys dil.** solution.
- Place the small centrifuge tube inside the small plastic beaker and charge it with the prescribed volumes of **Cu** solution and **H₂O₂ dil.** solution.
- Without delay**, insert the small centrifuge tube inside the black test tube – **gently, without mixing** the two solutions!



- Close the test tube with its screw-on cap. Make sure that the tube is closed tightly, because you will be shaking it. **Caution: Do not force the cap beyond its end-point**, because the tube will start leaking. If this happens, you must ask for a replacement immediately (penalty rules apply).
- Have the stopwatch ready in your hand, in timing mode. The moment you begin shaking the test tube, start timing. You must shake vigorously during the initial 10 seconds, so that the two solutions mix perfectly. It is crucial that you do not cut down the shaking time.
- Return the test tube into the conical flask, open the lid and watch the solution inside closely. It may help to shield away the daylight with your hand. Eventually, you will see a flash of blue light through the whole solution. At that moment, stop timing.
- Immediately, insert the metal probe of the digital thermometer into the black test tube. Wait for the reading to stabilise (typically 10–30 s) and record the reaction time and the reaction temperature.
- Using tweezers, remove the small centrifuge tube from the black test tube. After each experiment, empty and wash both tubes and dry them with paper wipes.

Measured data and their evaluation

P2.1 In the following table, record your experimental results for concentration set #1. To the displayed temperature add the thermometer's calibration constant. Look up the value of the normalisation coefficient $n_{x \rightarrow 25}$ for each temperature in Table P2 and calculate the reaction times normalised to 25 °C. In an unlikely case that your temperatures are not listed in Table P2, get the value of $n_{x \rightarrow 25}$ from the lab assistant.

Note: In a titration, the concordant values are within $\pm 0.1 \text{ cm}^3$. Here, concordant values of the normalised times for concentration set #1 are within $\pm 2.3 \text{ s}$.

(Use as many replicates as you consider necessary, you do not need to fill in all the rows. Points will be awarded for the accepted value only.)

	Repli- cate	Reaction time [s] 1 decimal place	Displayed temperature [°C] 1 decimal place	Corrected temperature [°C] 1 decimal place	Reaction time normalised to 25 °C [s] 3 significant figures
Conc. set #1	1				
	2				
	3				
	Accepted value of the normalised reaction time for concentration set #1				



P2.2 In the following table, record your experimental results, the corrected temperature and calculate the reaction times normalised to 25 °C for concentration set #2.

Note: Here, concordant values of the normalised times for concentration set #2 are within ± 3.0 s.

(Use as many replicates as you consider necessary; you do not need to fill in all the rows. Points will be awarded for the accepted value only.)

	Repli- cate	Reaction time [s] 1 decimal place	Displayed temperature [°C] 1 decimal place	Corrected temperature [°C] 1 decimal place	Reaction time normalised to 25 °C [s] 3 significant figures
Conc. set #2	1				
	2				
	3				
	Accepted value of the normalised reaction time for concentration set #2				

P2.3 Based on the procedure and on the concentrations of the stock solutions (specified in the list of chemicals and in Part I. of the Procedure), calculate the initial concentrations of cysteine, copper and H₂O₂ in both concentration sets.

Express the accepted reaction times (t_1 and t_2) from P2.1 and P2.2 in minutes and calculate the corresponding reaction rates (v_1 and v_2), expressed as the rates of the consumption of the cysteine concentration, in $\text{mmol dm}^{-3} \text{min}^{-1}$. You can assume that the rate of cysteine consumption during the reaction is constant.

If you cannot find the reaction rate, use the value 11.50 for conc. set #1 and 5.500 for conc. set #2 in further calculations.

	Initial concentrations [mmol dm ⁻³] 3 significant figures			Accepted reaction time [min] 4 significant figures	Reaction rate [mmol dm ⁻³ min ⁻¹] 4 significant figures
	Cysteine	Copper [Cu]	H ₂ O ₂		
Conc. set #1					
Conc. set #2					



P2.4 Assuming the rate equation can be expressed as

$$v = k [\text{H}_2\text{O}_2]^p$$

use your experimental data to calculate the partial reaction order p with respect to H_2O_2 . Write down your answer with 2 decimal places and show your calculation.

Answer: $p =$

Calculation:

An expression of the rate law of cysteine consumption that is closer to reality is more complicated and takes the following form:

$$v = k_1[\text{H}_2\text{O}_2][\text{Cu}] + k_2[\text{Cu}]$$

P2.5 Using the data from P2.3, evaluate the dependence of v on $[\text{H}_2\text{O}_2]$ as a linear function to find the slope and the intercept. Write down both answers with 4 significant figures. If you cannot find constants a and b , use the value 11.50 for both a and b in further calculations.

Answers (do not include the calculation, but include units):

$$v = a[\text{H}_2\text{O}_2] + b$$

$a =$

$b =$

P2.6 Use the numeric values from P2.5 to evaluate the rate constants k_1 and k_2 . Write down their values with 3 significant figures.

Answers (including units):

$k_1 =$

$k_2 =$

Calculations:



Table P2. Normalisation coefficients $n_{x \rightarrow 25}$ for converting reaction times measured at various temperatures to times representing the reactions at 25.0 °C.

Temp. °C	Set #1	Set #2
22.0	0.8017	0.8221
22.1	0.8076	0.8274
22.2	0.8135	0.8328
22.3	0.8195	0.8382
22.4	0.8255	0.8437
22.5	0.8316	0.8492
22.6	0.8377	0.8547
22.7	0.8438	0.8603
22.8	0.8500	0.8659
22.9	0.8563	0.8715
23.0	0.8626	0.8772
23.1	0.8690	0.8829
23.2	0.8754	0.8887
23.3	0.8818	0.8945
23.4	0.8884	0.9004
23.5	0.8949	0.9063
23.6	0.9015	0.9122
23.7	0.9082	0.9182
23.8	0.9149	0.9242
23.9	0.9217	0.9303
24.0	0.9285	0.9364
24.1	0.9354	0.9425
24.2	0.9424	0.9487
24.3	0.9494	0.9550
24.4	0.9564	0.9613
24.5	0.9636	0.9676
24.6	0.9707	0.9740
24.7	0.9780	0.9804
24.8	0.9852	0.9869
24.9	0.9926	0.9934
25.0	1.0000	1.0000
25.1	1.0075	1.0066
25.2	1.0150	1.0133
25.3	1.0226	1.0200
25.4	1.0302	1.0268
25.5	1.0379	1.0336
25.6	1.0457	1.0404

Temp. °C	Set #1	Set #2
25.7	1.0536	1.0474
25.8	1.0614	1.0543
25.9	1.0694	1.0613
26.0	1.0774	1.0684
26.1	1.0855	1.0755
26.2	1.0937	1.0827
26.3	1.1019	1.0899
26.4	1.1102	1.0972
26.5	1.1186	1.1045
26.6	1.1270	1.1119
26.7	1.1355	1.1194
26.8	1.1441	1.1268
26.9	1.1527	1.1344
27.0	1.1614	1.1420
27.1	1.1702	1.1497
27.2	1.1790	1.1574
27.3	1.1879	1.1651
27.4	1.1969	1.1730
27.5	1.2060	1.1809
27.6	1.2151	1.1888
27.7	1.2243	1.1968
27.8	1.2336	1.2049
27.9	1.2430	1.2130
28.0	1.2524	1.2212
28.1	1.2619	1.2294
28.2	1.2715	1.2377
28.3	1.2812	1.2461
28.4	1.2909	1.2545
28.5	1.3008	1.2630
28.6	1.3107	1.2716
28.7	1.3207	1.2802
28.8	1.3307	1.2889
28.9	1.3409	1.2976
29.0	1.3511	1.3064
29.1	1.3615	1.3153
29.2	1.3719	1.3243
29.3	1.3823	1.3333

Temp. °C	Set #1	Set #2
29.4	1.3929	1.3424
29.5	1.4036	1.3515
29.6	1.4143	1.3607
29.7	1.4252	1.3700
29.8	1.4361	1.3793
29.9	1.4471	1.3888
30.0	1.4582	1.3983
30.1	1.4694	1.4078
30.2	1.4807	1.4175
30.3	1.4921	1.4272
30.4	1.5035	1.4369
30.5	1.5151	1.4468
30.6	1.5267	1.4567
30.7	1.5385	1.4667
30.8	1.5503	1.4768
30.9	1.5623	1.4869
31.0	1.5743	1.4972
31.1	1.5865	1.5075
31.2	1.5987	1.5179
31.3	1.6111	1.5283
31.4	1.6235	1.5388
31.5	1.6360	1.5495
31.6	1.6487	1.5602
31.7	1.6614	1.5709
31.8	1.6743	1.5818
31.9	1.6872	1.5927
32.0	1.7003	1.6038
32.1	1.7135	1.6149
32.2	1.7268	1.6260
32.3	1.7402	1.6373
32.4	1.7536	1.6487
32.5	1.7673	1.6601
32.6	1.7810	1.6716
32.7	1.7948	1.6833
32.8	1.8087	1.6950
32.9	1.8228	1.7068
33.0	1.8370	1.7186



Practical Problem 3 13% of the total	Question	3.1	3.2	3.3	3.4	3.5	
	Points	3	20	2	2	16	
	Score						
	Question	3.6	3.7	3.8	3.9	3.10	Total
	Points	4	20	2	4	2	75
	Score						

Problem P3. Mineral water identification

Many mineral and thermal water springs are registered in Slovakia. Mineral waters with a balanced composition and natural or modified carbon dioxide content are sold for daily consumption. These waters do not contain nitrites, nitrates, phosphates, fluorides and sulfides and are also free of iron and manganese.

The mass concentration of the most important ions is reported on the packaging.

Your task is to identify the trade brand (from Table P3.1) of your mineral water sample.

Note: CO₂ has been removed from the sample.

Table P3.1. Mass concentrations of ions in selected Slovak mineral waters. (As reported by the supplier.)

No.	Trade brand	Mass concentration of ion, mg dm ⁻³						
		Ca ²⁺	Mg ²⁺	Na ⁺	K ⁺	Cl ⁻	SO ₄ ²⁻	HCO ₃ ⁻
1	Kláštorná	290	74	71	16	15	89	1 341
2	Budišská	200	50	445	50	25	433	1 535
3	Baldovská	378	94	90	0	78	215	1 557
4	Santovka	215	67	380	45	177	250	1 462
5	Slatina	100	45	166	40	104	168	653
6	Fatra	45	48	550	16	36	111	1 693
7	Ľubovnianska	152	173	174	5	10	20	1 739
8	Gemerka	376	115	85	0	30	257	1 532
9	Salvator	473	161	214	30	116	124	2 585
10	Brusnianska	305	101	187	35	59	774	884
11	Maxia	436	136	107	18	37	379	1 715

**Notes:**

- Use the prescribed symbols in the notations of calculations.
- You are provided with a swollen cation exchange resin (**Catex**) in its H⁺ form. Use a thick stem Pasteur pipette for transferring it. You can add more deionised water to the resin if necessary (it should not dry out).
- Concentrations of the standard solutions:
 $c(\text{NaOH}) = 0.2660 \text{ mol dm}^{-3}$ $c(\text{EDTA}) = 5.965 \times 10^{-3} \text{ mol dm}^{-3}$

Procedure

1.a Measure 5.00 cm³ of the catex into the graduated cylinder (volume V1). Then using deionised water transfer the catex quantitatively into a titration (kind-of-round, flat bottomed) flask. Add an appropriate amount of deionised water so that the suspension can be swirled well and the colour of the solution over the catex can be observed.

1.b Add 3–4 drops of the bromothymol blue indicator (**BTB**) and about 1 g (half a spoon) of solid NaCl. When NaCl dissolves, titrate all the suspension with the standard sodium hydroxide solution (volume V2) from yellow to blue. Close to the equivalence point, titrate slowly and swirl well so that any analyte inside the catex skeleton may diffuse into the solution. Repeat the experiment as necessary.

1.c After the titration, decant and discard most of the aqueous solution in the titration flask above the catex and transfer the suspension to the **Waste catex** container.

P3.1 Write down all the chemical reactions which occur in Step 1. Use R–H as a formula for the catex in a H⁺ form and HInd for the indicator.

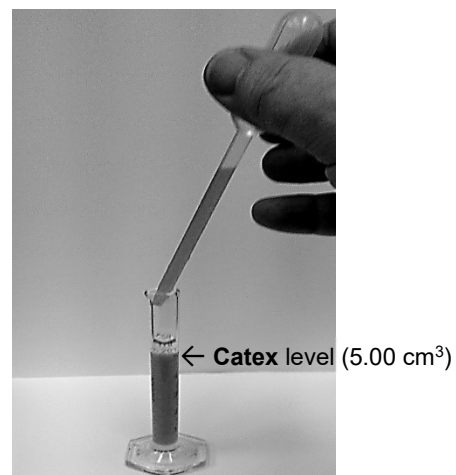



P3.2 Enter the experimental and accepted values from Step 1 into the table.

(You do not need to fill in all the rows.)

Analysis No.	Catex volume V_1 [cm ³]	NaOH consumption V_2 [cm ³]
1	5.00	
2		
3		
Accepted value V_2 4 significant figures		

P3.3 Using the accepted value of V_2 , calculate the ion exchange volume capacity $Q_v(\text{H}^+)$ in mmol cm^{-3} .

Calculation:

If you cannot find the $Q_v(\text{H}^+)$ value, use $1.40 \text{ mmol cm}^{-3}$ for further calculations.

- 2.a Using a graduated cylinder, measure 5.00 cm^3 of the swollen catex (volume V_3). Transfer the measured catex quantitatively into the 250 cm^3 beaker. Using a pipette, add 50.00 cm^3 of your sample (volume V_4). Swirl the mixture occasionally for about 5 minutes. Use the conical flask as a stand for the funnel and to collect the filtrate. Then filter the catex through a fritted (sintered) funnel (porosity **S1**) and wash it with deionised water to a neutral pH (check with pH paper). Discard the filtrate.
- 2.b Using deionised water, transfer the catex quantitatively from the funnel into a titration flask.
- 2.c Add 3–4 drops of bromothymol blue indicator and about 1 g (half a spoon) of solid NaCl and titrate the suspension with the standard sodium hydroxide solution (volume V_5) from yellow to blue. Repeat the experiment as necessary.
- 2.d After the titration, decant and discard most of the aqueous solution in the titration flask above the catex and transfer the suspension to the **Waste catex** container.



P3.4 Write down the equations for the ion exchange reactions. Monovalent and divalent ions should be abbreviated M^+ and M^{2+} , respectively.

P3.5 Enter the experimental and accepted values from Step 2 into the table.

(You do not need to fill in all the rows.)

Analysis No.	Catex volume V_3 [cm ³]	Sample volume V_4 [cm ³]	NaOH consumption V_5 [cm ³]
1	5.00	50.00	
2			
3			
Accepted value V_5 4 significant figures			

P3.6 Assuming that all the ions in your solution are M^+ ions, calculate, for the accepted value of V_5 , the molar concentration of cations (as M^+ molar concentration) in mineral water, $c^*(M^+)$, in mmol dm⁻³.

Calculation:

If you cannot find the $c^*(M^+)$ value, use 35.00 mmol dm⁻³ for further procedure.



In the next step, you are going to perform complexometric analysis to determine the concentration of Ca^{2+} and Mg^{2+} together (hereinafter written as M^{2+}).

3. Pipette 10.00 cm^3 (V_6) of the sample into the titration flask and add approx. 25 cm^3 of deionised water. Adjust pH by adding 3 cm^3 of the buffer solution. Add some Eriochrome black T indicator (**EBT**, on the tip of the spatula) and titrate with the standard EDTA solution from wine red to blue (V_7).

P3.7 Enter the experimental and accepted values from Step 3 into the table.

(You do not need to fill in all the rows)

Analysis No.	Sample volume V_6 [cm^3]	EDTA consumption, V_7 [cm^3]
1	10.00	
2		
3		
Accepted value V_7 4 significant figures		

- P3.8 For the accepted volume of V_7 , calculate the molar concentration of M^{2+} cations in mineral water, $c(\text{M}^{2+})$ in mmol dm^{-3} .

Calculation:

If you cannot find the $c(\text{M}^{2+})$ value, use $15.00 \text{ mmol dm}^{-3}$ for further solution.

4. Use Table P3.2 in the next identification procedure.

- P3.9 In Table P3.2, write down experimentally found values from tasks P3.6 and P3.8 and tick (✓) all the lines with an approximate match ($\pm 10\%$) of the found parameter $c(\text{M}^{2+})$ and $c^*(\text{M}^+)$ with the data from the table.



Table P3.2

Mineral water		Supplier data			Match with the experiment	
No.	Trade brand	$c(\text{M}^{2+})$ [mmol dm ⁻³]	$c(\text{M}^+)$ [mmol dm ⁻³]	Total equivalent concentration of cations $c^*(\text{M}^+)$ [mmol dm ⁻³]	Conformity for $c(\text{M}^{2+})$	Conformity for $c^*(\text{M}^+)$
Your exp. values			XXX		XXX	XXX
1	Kláštorná	10.30	3.50	24.1		
2	Budišská	7.06	20.63	34.7		
3	Baldovská	13.32	3.91	30.5		
4	Santovka	8.13	17.67	33.9		
5	Slatina	4.35	8.25	16.9		
6	Fatra	3.11	24.32	30.5		
7	Ľubovnianska	10.92	7.70	29.5		
8	Gemerka	14.13	3.70	32.0		
9	Salvator	18.46	10.07	47.0		
10	Brusnianska	11.79	9.03	32.6		
11	Maxia	16.50	5.11	38.1		

P3.10 Based on your results, decide which mineral water is in your sample. Tick (✓) the cross-reference number(s) of the mineral water(s).

No.		Trade brand	No.		Trade brand
1	<input type="checkbox"/>	Kláštorná	7	<input type="checkbox"/>	Ľubovnianska
2	<input type="checkbox"/>	Budišská	8	<input type="checkbox"/>	Gemerka
3	<input type="checkbox"/>	Baldovská	9	<input type="checkbox"/>	Salvator
4	<input type="checkbox"/>	Santovka	10	<input type="checkbox"/>	Brusnianska
5	<input type="checkbox"/>	Slatina	11	<input type="checkbox"/>	Maxia
6	<input type="checkbox"/>	Fatra	12	<input type="checkbox"/>	other



Replaced chemicals and equipment

Item or incident	Penalty	Signature	
		Student	Lab assistant
	0 pt		