

14th



**7 theoretical problems
3 practical problems**

THE FOURTEENTH INTERNATIONAL CHEMISTRY OLYMPIAD

STOCKHOLM 1982
SWEDEN

THEORETICAL PROBLEMS

PROBLEM 1

A. The IUPAC name of the compound $[\text{Co}(\text{NH}_3)_6]\text{Cl}_2$ is

- cobalt(II) hexaammonia dichlorine,
- cobalt(II) hexaammonia dichloride,
- hexaamminecobalt(II) chloride.
- hexaamminedichlorocobalt(II)
- cobalt(II) chloride-hexaammonia

B. The IUPAC name of the compound

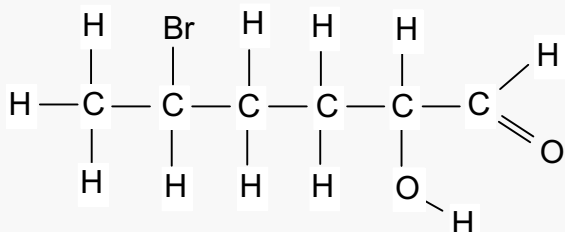

is:

- 5-bromo-1-hexanoic acid
 - 5-bromo-2-hydroxy-1-hexanal
 - 2-bromo-5-hydroxy-6-hexanal
 - 2-bromo-2-hydroxy-1-hexanal
 - 5-bromo-2-hydroxy-1-hexanone
- C. Which of the following acid-base pairs is most suitable for keeping the pH constant at 9 in an aqueous solution?
- $\text{CH}_3\text{COOH} \text{ — } \text{CH}_3\text{COO}^-$
 - $\text{NH}_4^+ \text{ — } \text{NH}_3$

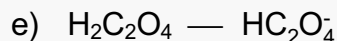
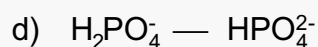
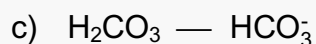

D. One of the following statements cannot be correct. State which one.

- a) A water-soluble solid contains Mg^{2+} , Cr^{3+} , and Br^- .
- b) A solid soluble in a sodium hydroxide solution contains Al^{3+} , K^+ , and SO_4^{2-} .
- c) A solid soluble in aqueous ammonia solution contains Ag^+ , Cu^{2+} , and Cl^- .
- d) A solid soluble in nitric acid contains Ba^{2+} , Fe^{2+} , and CO_3^{2-} .
- e) A solution neutral to litmus contains Na^+ , Ca^{2+} , and PO_4^{3-} .

E. Complete the following equation:

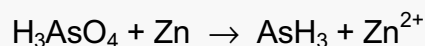

The reaction is carried out in an acid solution. Fill in the missing particles and balance the reaction equation.

F. State the degree of protolysis of acetic acid with concentration of 0.25 mol dm^{-3} .

$$K_a(\text{HAc}) = 1.8 \times 10^{-5}$$

- a) 0.021 %; b) 0.21 %; c) 0.84 %; d) 1.3 %; e) 8.4 %

G. A solution with a volume of 1.00 dm^3 is saturated with lead iodide, PbI_2 . The concentration of iodide ions is 2.7 mol dm^{-3} . Determine the solubility product of PbI_2 .

- a) 3.6×10^{-6} ; b) 2.0×10^{-8} ; c) 9.8×10^{-9} ; d) 2.5×10^{-9} ; e) 4.9×10^{-9} .

H. The following standard enthalpies of formation are given:

Compound	ΔH^0
Acetic acid	$-0.50 \text{ MJ mol}^{-1}$
Carbon dioxide	$-0.40 \text{ MJ mol}^{-1}$
Water	$-0.30 \text{ MJ mol}^{-1}$

The ΔH^0 of combustion of acetic acid is:

- a) 0.90 MJ mol^{-1} ; b) $-0.90 \text{ MJ mol}^{-1}$; c) $-0.20 \text{ MJ mol}^{-1}$;
d) -2.1 MJ mol^{-1} ; e) 0.20 MJ mol^{-1}

I. $\text{COCl}_2(\text{g})$ is introduced in an empty vessel at a pressure of a . It dissociates and the following equilibrium is established at constant temperature:

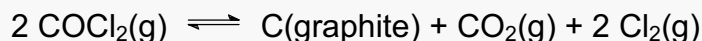

If x represents the partial pressure of $\text{CO}_2(\text{g})$ at equilibrium, what is the equilibrium expression?

a) $\frac{4x^3}{(a-2x)^2} = K_p$ b) $\frac{2x^4}{(a-2x)^2} = K_p$ c) $\frac{2x^3}{(a-x)^2} = K_p$

d) $\frac{4x^3}{(a-x)^2} = K_p$ e) $\frac{x^3}{(a-3x)^2} = K_p$

K. For a metal M the following redox data are known:

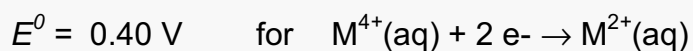

The E^0 for $\text{M}^{4+}(\text{aq}) + 3 \text{e}^- \rightarrow \text{M}^+(\text{aq})$ is then:

a) -0.20 V b) -1.00 V c) 1.00 V d) 0.07 V e) -0.07 V

SOLUTION

A. c) B. b) C. b) D. e)

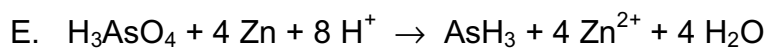

F. c) G. c) H. b) I. a) K. d)

PROBLEM 2

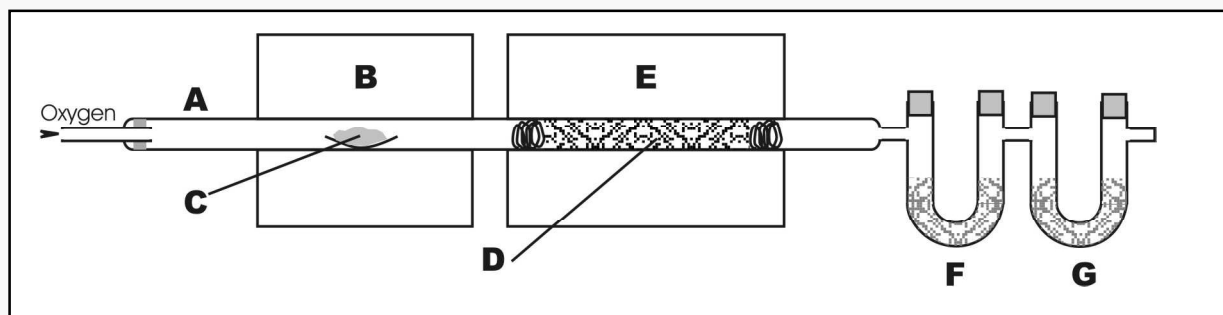

Quantitative analysis for carbon and hydrogen was originally carried out using a technique and apparatus (see figure) originally developed in 1831 by the famous chemist Justus Liebig. A carefully weighed sample of organic compound (C) is placed in a combustion tube (A) and vaporized by heating in a furnace (B). The vapours are swept by a stream of oxygen through a heated copper oxide packing (D) and through another furnace (E), which ensures the quantitative oxidation of carbon and hydrogen to carbon dioxide and water. The water vapour is absorbed in a weighed tube (F) containing magnesium perchlorate and the carbon dioxide in another weighed tube (G) containing asbestos impregnated with sodium hydroxide.

A pure liquid sample containing only carbon, hydrogen and oxygen is placed in a 0.57148 g platinum boat, which on reweighing weights 0.61227 g. The sample is ignited and the previously weighed absorption tubes are reweighed. The mass of the water absorption tube has increased from 6.47002 g to 6.50359 g, and the mass of the carbon dioxide tube has increased from 5.46311 g to 5.54466 g.

- Calculate the mass composition of the compound.
- Give the empirical formula of the compound.

To estimate the molar mass of the compound, 1.0045 g was gasified. The volume, measured at a temperature of 350 K and a pressure of 35.0 kPa, was 0.95 dm³.

- Give the molar mass and the molecular formula of the compound.
- Draw possible structures corresponding to the molecular formula excluding cyclic structures, stereo isomers, peroxides and unsaturated compounds. There are about 15 possibilities. Give 10 of them.

When the compound is heated with a sodium hydroxide solution, two products are formed. Fractional distillation of the reaction mixture yields one of the substances. The other substance is purified by distillation after acidification and appears to be an acid.

e) What structures are possible for compound C?

0.1005 g of the acid are dissolved in water and titrated with a sodium hydroxide solution with a concentration of $0.1000 \text{ mol dm}^{-3}$. The indicator changes colour on addition of 16.75 cm^3 of hydroxide solution.

f) What was the original substance C?

SOLUTION

- a) Mass percentage composition: 54.56 % C; 9.21 % H; 36.23 % O
- b) Empirical formula: $\text{C}_2\text{H}_4\text{O}$
- c) Molar mass: 88 g mol^{-1}
Molecular formula: $\text{C}_4\text{H}_8\text{O}_2$
- d) Possible structures:
- | | |
|--|--|
| 1. $\text{CH}_3\text{-CH}_2\text{-CH}_2\text{-COOH}$ | 11. $\text{CH}_2(\text{OH})\text{-CH}(\text{CH}_3)\text{-CHO}$ |
| 2. $\text{CH}_3\text{-CH}(\text{CH}_3)\text{-COOH}$ | 12. $\text{CH}_3\text{-O-CH}_2\text{-CH}_2\text{-CHO}$ |
| 3. $\text{CH}_3\text{-O-CO-CH}_2\text{-CH}_3$ | 13. $\text{CH}_3\text{-CH}_2\text{-O-CH}_2\text{-CHO}$ |
| 4. $\text{CH}_3\text{-CH}_2\text{-O-CO-CH}_3$ | 14. $\text{CH}_3\text{-O-CH}(\text{CH}_3)\text{-CHO}$ |
| 5. $\text{CH}_3\text{-CH}_2\text{-CH}_2\text{-O-CO-H}$ | 15. $\text{CH}_3\text{-CH}_2\text{-CO-CH}_2\text{-OH}$ |
| 6. $\text{CH}_3\text{-CH}(\text{CH}_3)\text{-O-CO-H}$ | 16. $\text{CH}_3\text{-CH}(\text{OH})\text{-CO-CH}_3$ |
| 7. $\text{CH}_3\text{-CH}_2\text{-CH}(\text{OH})\text{-CHO}$ | 17. $\text{CH}_2(\text{OH})\text{-CH}_2\text{-CO-CH}_3$ |
| 8. $\text{CH}_3\text{-CH}(\text{OH})\text{-CH}_2\text{-CHO}$ | 18. $\text{CH}_3\text{-O-CH}_2\text{-CO-CH}_3$ |
| 9. $\text{CH}_2(\text{OH})\text{-CH}_2\text{-CH}_2\text{-CHO}$ | |
| 10. $\text{CH}_3\text{-C}(\text{OH})(\text{CH}_3)\text{-CHO}$ | |
- e) The possible structures are 3, 4, 5, 6.
- f) The structure of the compound C is $\text{CH}_3\text{-CH}_2\text{-O-CO-CH}_3$.

PROBLEM 3

In a chemical factory in which formaldehyde is produced by oxidation of methanol, aqueous solutions containing methanol and formaldehyde are to be analyzed. In order to test the method, experiments are first carried out with known amounts of both methanol and formaldehyde. The following aqueous solutions are used:

Methanol, 5.00 g dm^{-3}

Formaldehyde, 5.00 g dm^{-3}

Potassium dichromate, $3.000 \times 10^{-2} \text{ mol dm}^{-3}$

Ammonium iron(II) sulphate, $0.2000 \text{ mol dm}^{-3}$

Iodine, $0.1000 \text{ mol dm}^{-3}$

Sodium thiosulphate, $0.2000 \text{ mol dm}^{-3}$.

I. 10.00 cm^3 methanol solution and 100.00 cm^3 potassium dichromate solution are mixed, approximately 100 cm^3 concentrated sulphuric acid is added and the solution is allowed to stand for about 30 minutes. Excess dichromate ions are then titrated with iron(II) ions with diphenylamine sulphonc acid as a redox indicator (colour change from red-violet to pale green). The volume of the iron(II) solution consumed is 43.5 cm^3 .

II. 10.00 cm^3 of formaldehyde solution and 50.00 cm^3 of iodine solution are mixed. Sodium hydroxide solution is added to alkaline reaction and the mixture is left standing for about 10 minutes. Hydrochloric acid is then added to a neutral reaction, and the excess iodine is determined by titration with thiosulphate, with starch as an indicator. The volume of the thiosulphate solution required is 33.3 cm^3 .

a) Using the analysis data in I and II calculate the reacting amounts and the molar ratios of methanol/dichromate ions and formaldehyde/iodine.

b) Write balanced equations for all reactions described in experiments I and II.

III. It is checked that iodine does not react with methanol. From a solution containing both methanol and formaldehyde, two 10.00 cm^3 samples are taken.

One sample is mixed with 100.00 cm^3 of potassium dichromate solution and concentrated sulphuric acid as in I. Excess dichromate ions consume 4.8 cm^3 of iron(II) solution.

The other sample is mixed with 50.00 cm³ of iodine solution and treated as in II. Excess iodine consumes 16.50 cm³ of thiosulphate solution.

c) Give balanced equations for the reactions and calculate the contents of methanol and formaldehyde in the solution. Give your answer in g dm⁻³.

SOLUTION

a) Amounts of substance:

methanol	1.56 mol
dichromate ions	3.00 mol
iron(II) ions	8.70 mol

Molar ratio methanol/dichromate: $1 \text{ mol CH}_3\text{OH} \Rightarrow 1 \text{ mol Cr}_2\text{O}_7^{2-}$

Amounts of substance:

formaldehyde	1.67 mol
iodine	5.00 mol
thiosulphate ions	6.66 mol

Molar ratio formaldehyde/iodine: $1 \text{ mol HCHO} \Rightarrow 1 \text{ mol I}_2$

b) Chemical equations:

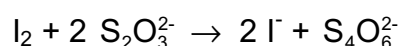
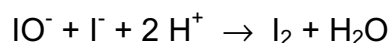
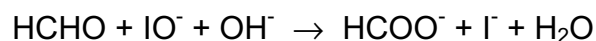
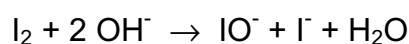
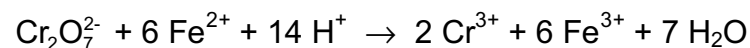
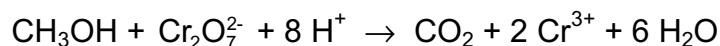

In (3), (5), and (6), I₃ may participate instead of I₂.

As an alternative to (4)



c) Chemical equations

To the chemical equations above is added

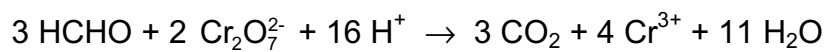

Content of methanol: 1.9 g dm^{-3}

Content of formaldehyde 10.1 g dm^{-3}

PROBLEM 4

A transition metal atom or ion may be directly bonded to a number of atoms or molecules that surround it (ligands), forming a characteristic pattern. This is the essential structural feature of an important class of so-called coordination or complex compounds. If two or more atoms from one individual ligand form bonds to the same central atom then the ligand is said to form a chelate (Greek chele = crab' claw).

The glycinate ion, $\text{NH}_2\text{-CH}_2\text{-COO}^-$, is a bidentate chelate ligand which can form, for instance, tris-glycinato-chromium(III) complexes. The figure shows one possible structure of such a complex. Oxygen and nitrogen are forced to coordinate to adjacent octahedral positions, as the N-C-C-O chain is too short to "embrace" the chromium ion.

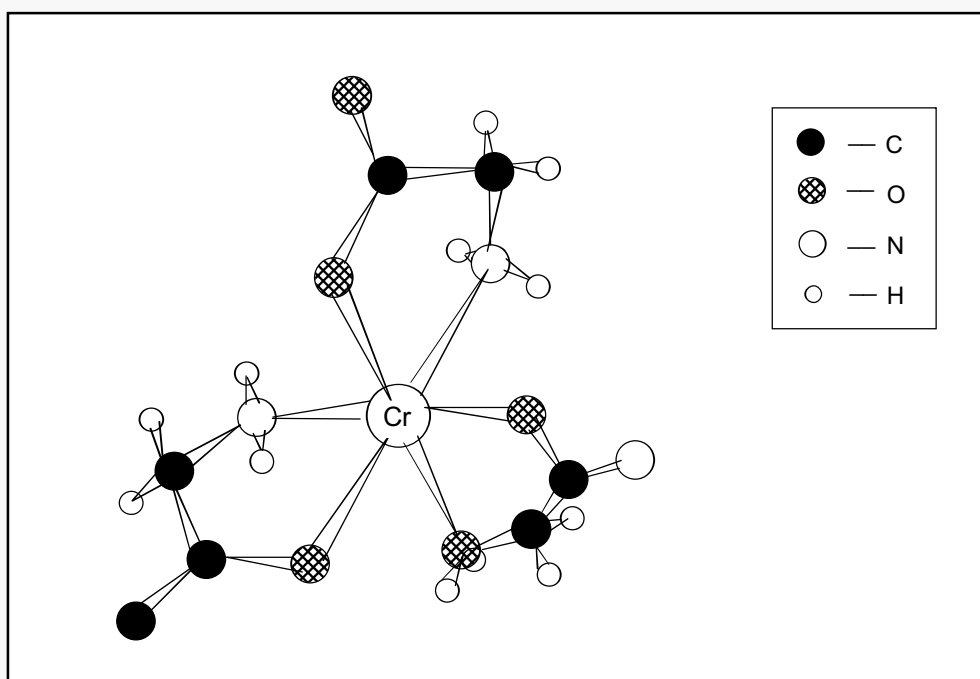

- How many different configurational isomers of the complex are possible, not counting optical isomers?
- Which of these isomers can be further resolved into optical isomers?

Another coordination compound of chromium was analyzed and found to have the following mass composition: 19.5 % Cr, 40.0 % Cl, 4.5 % H, and 36.0 % O. A 0.533 g

sample of the compound was dissolved in 100 cm³ of water, and 10 cm³ of nitric acid (2 mol dm⁻³) was added. Excess of silver nitrate solution was then added and the precipitate formed was then filtered, washed, dried and weighed. Its mass was found to be 0.287 g.

When a 1.06 g sample was gently heated to 100 °C in a stream of dry air, 0.144 g of water was driven off.

The freezing point of a solution prepared from 1.33 g of the compound and 100 cm³ of water, was found to be -0.18 °C. (Molar freezing point depression of water is 1.82 K kg mol⁻¹).

Use all the experimental information to solve the following problems:

- Derive the empirical formula of the compound.
- Deduce formula for the compound showing the ligands of the chromium ion. Give molar ratios to support your result.
- Sketch all possible steric arrangements of the ligands about the chromium ion.

SOLUTION

- Two geometrical isomers of the complex are possible:
 - the facial, which is the one illustrating the problem,
 - the meridional, with oxygen and nitrogen positions as shown:

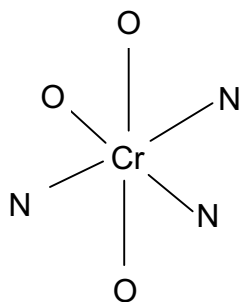

- It is clearly seen that any complex with three bidentate ligands attached octahedrally as shown, lacks mirror symmetry. Hence, both stereoisomers are further resolvable into optical isomers.
- The empirical formula is CrCl₃H₁₂O₆.
- The reaction with silver ions indicates that

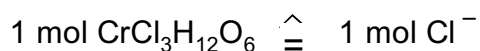

Gentle heating gives

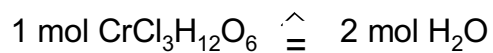

These results support the coordination $[\text{CrCl}_2(\text{H}_2\text{O})_4]\text{Cl} \cdot 2 \text{ H}_2\text{O}$.

This formula is supported by the freezing point experiment showing that

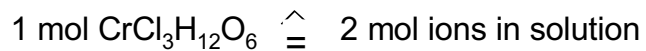

e) Possible steric arrangements of the ligands about the chromium atom:

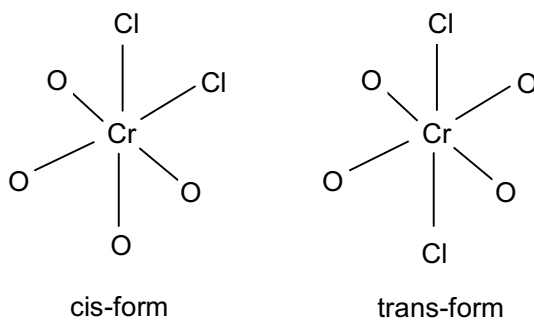

PROBLEM 5

Iodine is soluble to a certain extent in pure water. It is, however, more soluble in solutions containing iodide ions. By studying the total solubility of iodine as a function of iodide concentration, the equilibrium constants of the following reactions can be determined:

Equation	Equilibrium constants	
$I_2(s) \rightleftharpoons I_2(aq)$	k_1	(1)
$I_2(s) + I^-(aq) \rightleftharpoons I_3^-(aq)$	k_2	(2)
$I_2(aq) + I^-(aq) \rightleftharpoons I_3^-(aq)$	k_3	(3)

- a) Give the equilibrium equations for (1) – (3).

Solutions of known potassium iodide concentration $[I^-]_{tot}$ were equilibrated with solid iodine. Subsequent titration with sodium thiosulphate solution served to determine the total solubility of iodine $[I_2]_{tot}$.

The experiments yielded the following results:

$[I^-]_{tot} / \text{mmol dm}^{-3}$	10.00	20.00	30.00	40.00	50.00
$[I_2]_{tot} / \text{mmol dm}^{-3}$	5.85	10.53	15.11	19.96	24.82

- b) Plot $[I_2]_{tot}$ versus $[I^-]_{tot}$ in a diagram.
 c) Derive a suitable algebraic expression relating $[I_2]_{tot}$ and $[I^-]_{tot}$.
 d) Use the graph to determine values of the equilibrium constants k_1 , k_2 , and k_3 .

SOLUTION

- a) Equilibrium equations

The following relations are valid for the concentrations of the aqueous solutions:

$$[I_2] = k_1$$

$$\frac{[I_3^-]}{[I^-]} = k_2$$

$$\frac{[I_3^-]}{[I_2][I^-]} = k_3 = \frac{k_2}{k_1}$$

- b) See diagram on the next page.

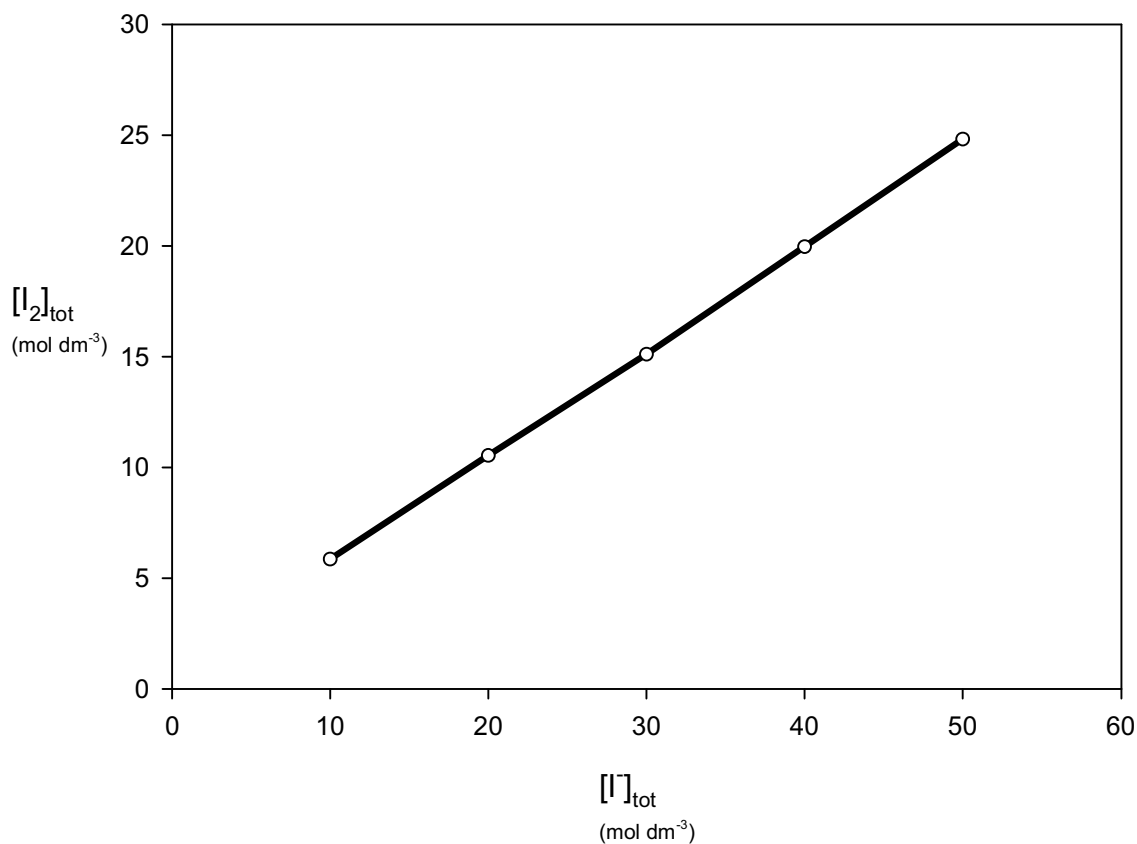

c) The relation between $[I_2]_{\text{tot}}$ and $[I]_{\text{tot}}$ is as follows:

$$[I_2]_{\text{tot}} = k_1 + \frac{k_2}{1 + k_2} [I]_{\text{tot}}$$

d) $k_1 = 1.04 \times 10^{-3} \text{ mol dm}^{-3}$ $k_2 = 0.90$ $k_3 = 8.6 \times 10^2 \text{ mol}^{-1} \text{ dm}^3$

(These values are calculated by the least square method.)

PROBLEM 6

A white solid organic acid, **A**, contains only carbon, hydrogen and oxygen. To obtain an approximate value for the molar mass, 10.0 g of the acid were dissolved in water. Crushed ice was added and vigorous shaking caused a decrease in temperature to $-2.5\text{ }^{\circ}\text{C}$. The ice was quickly removed. The mass of the solution was 76.1 g, and its pH value was determined to be 1.4. In a handbook the molar freezing point depression constant for water was found to be $1.86\text{ K kg mol}^{-1}$. A more precise determination of the molar mass of the acid was then carried out. 0.120 g of the acid was titrated with a sodium hydroxide solution with a concentration of 0.100 mol dm^{-3} . Phenolphthalein was used as an indicator, and when 23.4 cm^3 of hydroxide solution was added the indicator turned red.

a) Give the molar mass and the structure of acid **A**.

Liquid **B** dissolves in water up to 10 %. The pH value of the solution is about 4. **B** is not easily oxidized, but following the iodoform reaction and subsequent acidification it is oxidized to acid **A**. 0.10 g of **B** consumes 1.5 g of iodine.

When **B** reacts with sodium, hydrogen is evolved and a metal organic compound is formed. The molar mass of **B** is approximately 100 g mol^{-1} .

b) Write the chemical equation for the iodoform reaction and for the reaction with sodium. For the organic molecules structural formulas should be used.

Compound **C** in aqueous solution has a conductivity which differs very little from that of pure water. Alkaline hydrolysis of **C** yields ammonia. 0.120 g of **C** was treated with hot, dilute sodium hydroxide solution and the gas formed was led into 50.0 cm^3 hydrochloric acid with a concentration of 0.100 mol dm^{-3} . The excess acid was titrated with 10.0 cm^3 sodium hydroxide solution with a concentration of 0.100 mol dm^{-3} .

Acid hydrolysis of **C** yields carbon dioxide. From the freezing point depression, the molar mass of **C** is estimated to be between 40 g mol^{-1} and 70 g mol^{-1} .

c) Give the structure of **C**. Write reaction equations for both the alkaline and the acid hydrolysis.

If **C** is allowed to react with the ethyl ester of acid **A** in the presence of a strong alkaline catalyst, ethanol and compound **D** are formed. The composition of **D** is 37.5 % C, 3.1 % H, 21.9 % N, and the remainder is oxygen. The compound is an acid.

d) Give the structure for **D**. Which is the "acid" hydrogen atom? Mark it with * in the structure.

SOLUTION

a) Molar mass of **A**: 103 g mol^{-1}

Structure of **A**:

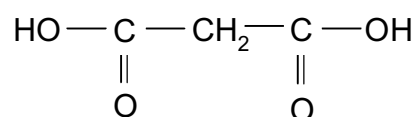

b) $\text{CH}_3\text{-CO-CH}_2\text{-CO-CH}_3 + 6 \text{I}_2 + 8 \text{OH}^- \rightarrow \text{O}^-\text{-CO-CH}_2\text{-CO-O}^- + 2 \text{CHI}_3 + 6 \text{I}^-$

$\text{O}^-\text{-CO-CH}_2\text{-CO-O}^- + 2 \text{H}^+ \rightarrow \text{HO-CO-CH}_2\text{-CO-OH}$

$2 \text{CH}_3\text{-CO-CH}_2\text{-CO-CH}_3 + 2 \text{Na} \rightarrow 2 \text{CH}_3\text{-CO-}\underline{\text{CH}}\text{-CO-CH}_3 + \text{H}_2 + 2 \text{Na}^+$

c) $\text{H}_2\text{N-CO-NH}_2$

$\text{H}_2\text{N-CO-NH}_2 + 2 \text{OH}^- \rightarrow 2 \text{NH}_3 + \text{CO}_3^{2-}$

$\text{H}_2\text{N-CO-NH}_2 + 2 \text{H}^+ + \text{H}_2\text{O} \rightarrow 2 \text{NH}_4^+ + \text{CO}_2$

d)

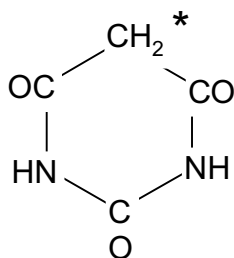

* - "acid" hydrogen

PROBLEM 7

Calcium oxalate, $\text{CaC}_2\text{O}_4 \cdot \text{H}_2\text{O}$, is a sparingly soluble salt of analytical and physiological importance. The solubility product is 2.1×10^{-9} at 25°C . Oxalate ions can protolyse to form hydrogen oxalate ions and oxalic acid. The pK_a values at 25°C are 1.23 ($\text{H}_2\text{C}_2\text{O}_4$) and 4.28 (HC_2O_4^-). At 25°C the ionic product of water is 1.0×10^{-14} .

- State those expressions for the equilibrium conditions which are of interest for the calculation of the solubility of calcium oxalate monohydrate.
- State the concentration conditions which are necessary for the calculation of the solubility s (in mol dm^{-3}) of calcium oxalate in a strong acid of concentration C .
- Calculate the solubility (in g dm^{-3}) of calcium oxalate monohydrate in a plant cell in which the buffer system regulates the pH to 6.5.
- Calculate the solubility (in g dm^{-3}) of calcium oxalate monohydrate in hydrochloric acid with a concentration of $0.010 \text{ mol dm}^{-3}$. Give the concentration of hydrogen ions in the solution.
- Calculate the equilibrium concentrations of all other species in solution d).

SOLUTION

$$\text{a) } [\text{Ca}^{2+}][\text{C}_2\text{O}_4^{2-}] = K_s \quad (1) \qquad [\text{H}^+][\text{OH}^-] = K_w \quad (2)$$

$$\frac{[\text{H}^+][\text{HC}_2\text{O}_4^-]}{[\text{H}_2\text{C}_2\text{O}_4]} = K_{a1} \quad (3) \qquad \frac{[\text{H}^+][\text{C}_2\text{O}_4^{2-}]}{[\text{HC}_2\text{O}_4^-]} = K_{a2} \quad (4)$$

$$\text{b) } s = [\text{Ca}^{2+}] = [\text{C}_2\text{O}_4^{2-}] + [\text{HC}_2\text{O}_4^-] + [\text{H}_2\text{C}_2\text{O}_4] \quad (5)$$

$$C = [\text{H}^+] + [\text{HC}_2\text{O}_4^-] + 2[\text{H}_2\text{C}_2\text{O}_4] - [\text{OH}^-] \quad (6)$$

Equations (5) or (6) may be replaced by

$$[\text{H}^+] + 2[\text{Ca}^{2+}] = [\text{HC}_2\text{O}_4^-] + 2[\text{C}_2\text{O}_4^{2-}] + [\text{OH}^-] + C \quad (7)$$

- The solubility of calcium oxalate monohydrate is 6.7×10^{-3} . (Calculated according to equation (8)).

- d) Elimination of the concentrations of oxalate species using equations (1), (3), and (4) yields the following expressions for (5) and (6). (The concentration of hydroxide ions can be neglected.)

$$s_2 = K_s + \frac{[\text{H}^+] K_s}{K_{a2}} + \frac{[\text{H}^+]^2 K_s}{K_{a1} K_{a2}} \quad (8)$$

$$C = [\text{H}^+] + \frac{[\text{H}^+] K_s}{s K_{a2}} + \frac{2[\text{H}^+]^2 K_s}{s K_{a1} K_{a2}} \quad (9)$$

Elimination of s from (8) and (9) results in 4th order equation. For this reason, an iterative method is to be preferred. The first approximation is $[\text{H}^+] = C$. This value of $[\text{H}^+]$ can be used to calculate:

- i) solubility s from (8),
- ii) the last two terms in (9), which are corrections. Now a new value for $[\text{H}^+]$ obtained from (9) may be used as a starting value for the next approximation. Two repeated operations give the following value for s :

$$s = 6.6 \times 10^{-4} \text{ mol dm}^{-3} = 9.6 \times 10^{-2} \text{ g dm}^{-3}$$

$$[\text{H}^+] = 9.3 \times 10^{-3} \text{ mol dm}^{-3}$$

- | | |
|--|---|
| e) $[\text{Ca}^{2+}] = 6.6 \times 10^{-4} \text{ mol dm}^{-3}$ | $[\text{C}_2\text{O}_4^{2-}] = 3.2 \times 10^{-6} \text{ mol dm}^{-3}$ |
| $[\text{Cl}^-] = 0.010 \text{ mol dm}^{-3}$ | $[\text{HC}_2\text{O}_4^-] = 5.7 \times 10^{-4} \text{ mol dm}^{-3}$ |
| $[\text{OH}^-] = 1.1 \times 10^{-12} \text{ mol dm}^{-3}$ | $[\text{H}_2\text{C}_2\text{O}_4] = 9.0 \times 10^{-5} \text{ mol dm}^{-3}$ |
-

PRACTICAL PROBLEMS

PROBLEM 1

A pH buffer solution has a well defined acidity which changes only very slightly upon addition of moderate quantities of strong acid or base. The larger is the quantity of acid or base that must be added to a certain volume of a buffer solution in order to change its pH by a specific amount, the better is its action. A buffer solution is prepared by mixing a weak acid and its conjugate base in appropriate amounts in a solution. An example of a useful buffer system in aqueous solution is the phosphate system.

Your task is to prepare a phosphate buffer with properties specified by the following two conditions:

- (1) pH = 7.20 in the buffer solution,
- (2) pH = 6.80 in a mixture of 50.0 cm³ of the buffer solution and 5.0 cm³ hydrochloric acid with a concentration of 0.100 mol dm⁻³.

Chemicals and equipment

Aqueous solution of phosphoric acid, sodium hydroxide solution of known concentration, hydrochloric acid (0.100 mol dm⁻³), solution of bromocresol green, distilled water.

Burettes, pipettes (25 and 5 cm³), Erlenmeyer flasks (100 and 250 cm³), volumetric flask (100 cm³), beaker, and funnel.

Procedure

Determine the concentration of the phosphoric acid solution by titration with a sodium hydroxide solution using bromocresol green as an indicator (pH range 3.8 < pH < 5.4).

Make a buffer solution by mixing calculated volumes of phosphoric acid and sodium hydroxide solutions in the volumetric flask and filling the flask to the mark with distilled water.

Mix in an Erlenmeyer flask 50.0 cm³ of the buffer solution with 5.0 cm³ of the hydrochloric acid.

Hand in your answer sheet to the referee who will also measure the pH of your two solutions and note your results.

The pK_a values for phosphoric acid are:

$$pK_{a1} = 1.75, \quad pK_{a2} = 6.73, \quad pK_{a3} = 11.50$$

SOLUTION

The buffer solution must contain

H₂PO₄⁻ (concentration **a** mol dm⁻³) and

HPO₄²⁻ (concentration **b** mol dm⁻³).

The concentrations should satisfy the condition

$$\frac{\mathbf{b}}{\mathbf{a}} = \frac{10^{-6.73}}{10^{-7.20}}$$

After addition of HCl the condition will be

$$\frac{50.0\mathbf{b} - 0.50}{50.0\mathbf{a} + 0.50} = \frac{10^{-6.73}}{10^{-6.80}}$$

From these equations,

$$\mathbf{a} = 0.0122 \quad \mathbf{b} = 0.0361$$

Total concentration of the phosphate system = 0.0483 mol dm⁻³

Total concentration of Na⁺ = (**a** + 2 **b**) mol dm⁻³ = 0.0844 mol dm⁻³

If the concentration of both phosphoric acid and sodium hydroxide solution are 0.500 mol dm⁻³, then 100.0 cm³ buffer solution will require:

$$\text{volume of H}_3\text{PO}_4 \text{ solution} = \frac{0.0483 \times 0.1000}{0.500 \text{ dm}^3} = 9.7 \text{ cm}^3$$

$$\text{volume of NaOH solution} = \frac{0.0844 \times 0.1000}{0.500 \text{ dm}^3} = 16.9 \text{ cm}^3$$

PROBLEM 2

Each of 8 numbered test tubes contains a solution of one salt. In the solutions the following positive ions can be found (a maximum of one in each test tube):

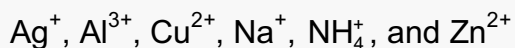

and the following negative ions (at most one in each test tube)

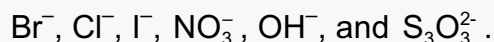

A test plate, test tubes in a rack, dropping pipettes, indicator paper, and a gas burner are also provided.

Determine by means of mutual reactions which salt is dissolved in each test tube. Confirm your conclusions by carrying out as many reactions as possible. It may be necessary to use combinations of solutions and reagents.

Give a list of numbers and corresponding formulae of the substances, indicate the formation of a precipitate by a downward arrow, and gas evolution by an upward arrow in the square array provided for reporting the reactions.

Write chemical equations for all the reactions observed.

SOLUTION

Numbers of solutions mixed	Chemical equation for the observed reaction
1 + 2	$\text{NH}_4^+ + \text{OH}^- \rightarrow \text{NH}_3(\text{g}) + \text{H}_2\text{O}$
2 + 3	$2 \text{OH}^- + 2 \text{Ag}^+ \rightarrow \text{Ag}_2\text{O}(\text{s}) + \text{H}_2\text{O}$
2 + 3 + 1	$\text{Ag}_2\text{O}(\text{s}) + 4 \text{NH}_4^+ + 2 \text{OH}^- \rightarrow 2 \text{Ag}(\text{NH}_3)_2^+ + 3 \text{H}_2\text{O}$
2 + 4	$\text{Zn}^{2+} + 2 \text{OH}^- \rightarrow \text{Zn}(\text{OH})_2(\text{s}) \leftrightarrow \text{Zn}(\text{OH})_2(\text{s}) + 2 \text{OH}^- \rightarrow \text{Zn}(\text{OH})_4^{2-}$
2 + 5	$\text{Al}^{3+} + 3 \text{OH}^- \rightarrow \text{Al}(\text{OH})_3(\text{s}) \leftrightarrow \text{Al}(\text{OH})_3(\text{s}) + \text{OH}^- \rightarrow \text{Al}(\text{OH})_4^-$

Reactions to distinguish Zn^{2+} from Al^{3+} :

Numbers of solutions mixed	Chemical equation for the observed reaction
2 + 4 + 1	$\text{Zn}(\text{OH})_4^{2-} + 4 \text{NH}_4^+ \rightarrow \text{Zn}(\text{NH}_3)_4^{2+} + 4 \text{H}_2\text{O}$
2 + 5 + 1	$\text{Al}(\text{OH})_4^- + 2 \text{NH}_4^+ \rightarrow \text{Al}(\text{OH})_3(\text{s}) + \text{NH}_3 + \text{H}_2\text{O}$
2 + 6	$\text{Cu}^{2+} + 2 \text{OH}^- \rightarrow \text{Cu}(\text{OH})_2(\text{s})$
2 + 6 + 1	$\text{Cu}(\text{OH})_2(\text{s}) + 4 \text{NH}_4^+ + 2 \text{OH}^- \rightarrow \text{Cu}(\text{NH}_3)_4^{2+} + 4 \text{H}_2\text{O}$
3 + 4	$\text{Ag}^+ + \text{Cl}^- \rightarrow \text{AgCl}(\text{s})$
3 + 6	$\text{Ag}^+ + \text{Br}^- \rightarrow \text{AgBr}(\text{s})$
3 + 7	$\text{Ag}^+ + \text{I}^- \rightarrow \text{AgI}(\text{s})$
3 + 8	$2 \text{Ag}^+ + \text{S}_2\text{O}_3^{2-} \rightarrow \text{Ag}_2\text{S}_2\text{O}_3(\text{s}) \leftrightarrow \text{Ag}_2\text{S}_2\text{O}_3(\text{s}) + 3 \text{S}_2\text{O}_3^{2-} \rightarrow$ $\rightarrow 2 \text{Ag}(\text{S}_2\text{O}_3)_2^{3-}$

Reactions to distinguish Cl^- from Br^- and from I^-

3 + 4 + 1 + 2	$\text{AgCl}(\text{s}) + 2 \text{NH}_4^+ + 2 \text{OH}^- \rightarrow \text{Ag}(\text{NH}_3)_2^+ + \text{Cl}^- + \text{H}_2\text{O}$
3 + 4 + 8	$\text{AgCl}(\text{s}) + 2 \text{S}_2\text{O}_3^{2-} \rightarrow \text{Ag}(\text{S}_2\text{O}_3)_2^{3-} + \text{Cl}^-$
3 + 6 + 1 + 2	AgBr(s) does not dissolve
3 + 6 + 8	$\text{AgBr}(\text{s}) + 2 \text{S}_2\text{O}_3^{2-} \rightarrow \text{Ag}(\text{S}_2\text{O}_3)_2^{3-} + \text{Br}^-$
3 + 7 + 8	AgI(s) does not dissolve
6 + 7	$2 \text{Cu}^{2+} + 4 \text{I}^- \rightarrow 2 \text{CuI}(\text{s}) + \text{I}_2$
6 + 7 + 8	$\text{I}_2(\text{s}) + 2 \text{S}_2\text{O}_3^{2-} \rightarrow 2 \text{I}^- + \text{S}_4\text{O}_6^{2-}$

THE FOURTEENTH INTERNATIONAL CHEMISTRY OLYMPIAD
Stockholm 1984, Sweden

	1	2	3	4	5	6	7	8
1		↑						
2	↑		↓	↓	↓	↓		
3		↓		↓		↓	↓	↓
4		↓	↓					
5		↓						
6		↓	↓				↓	
7			↓			↓		
8			↓					

List of numbers and corresponding formulae for the substances:

- | | |
|-----------------------------|--------------------------------------|
| 1. NH_4NO_3 | 5. $\text{Al}(\text{NO}_3)_3$ |
| 2. NaOH | 6. CuBr_2 |
| 3. AgNO_3 | 7. NaI |
| 4. ZnCl_2 | 8. $\text{Na}_2\text{S}_2\text{O}_3$ |

PROBLEM 3

Determination of the solubility product of lead(II) chloride

Shake solid lead(II) chloride:

- a) with water,
 - b) with three solutions of sodium chloride of different concentrations,
- until equilibrium is attained. Then determine the lead ion concentration by titration with EDTA. Calculate the solubility product of lead(II) chloride.

Equipment and chemicals

Volumetric flask (100 cm³), pipettes (20 cm³ and 10 cm³), graduated cylinder (100 cm³ and 25 cm³), 4 Erlenmeyer flasks (200 – 250 cm³) with stoppers, spatula, 4 filter funnels, filter papers, thermometer, 4 Erlenmeyer flasks (100 cm³), titrating flasks (200 – 250 cm³), beakers, stand with burette (50 cm³), burette funnel, wash bottle with distilled water, glass rod.

Standard solutions of sodium chloride (0.1000 mol dm⁻³) and EDTA (0.01000 mol dm⁻³), solid lead(II) chloride, xylene orange solution in a dropping bottle (0.5 % in water), solid hexamine (urotropine), nitric acid (2.5 mol dm⁻³) in a dropping bottle.

Procedure

1. Prepare 100 cm³ of sodium chloride solutions with concentrations of 0.0600 mol dm⁻³, 0.0400 mol dm⁻³, and 0.0200 mol dm⁻³, respectively. Place the solutions in Erlenmeyer flasks with stoppers. Place 100 cm³ of water in the fourth flask with a stopper. Add 5 spatulas of solid lead(II) chloride (about 2 g) to each, stopper the flasks and shake vigorously. Let the flasks stand for 30 minutes. Shake them occasionally. Prepare for filtration and titration in the meanwhile.
2. Measure the temperatures of the lead(II) chloride solutions and report them in the table of results. Filter the solutions through dry filters into small, dry Erlenmeyer flasks.
3. Using a pipette, transfer 10.00 cm³ of the filtrate into a titration flask. Dilute with approximately 25 cm³ of water, add 3 drops of xylene orange (indicator) and 5 drops of

nitric acid. Then add 5 spatulas (about 0.5 g) of solid hexamine (a weak base) and swirl gently until the solution is clear. Titrate with EDTA.

4. Calculate the concentration of lead ions and that of chloride ions in the solutions and give the solubility product K_s . Report the results in the table.
5. Answer the questions in the answer sheet.

Questions

- a) Give the structure of EDTA. Mark those atoms which can coordinate to a metal ion with an asterisk (*).
- b) Give the equation for the filtration reaction. EDTA may be written as H_2X^{2-} .

SOLUTION

A typical result

$c(\text{NaCl})$ (mol dm^{-3})	Temperature ($^{\circ}\text{C}$)	Volume EDTA solution (cm^3)	$[\text{Pb}^{2+}]$ (mol dm^{-3})	$[\text{Cl}^-]$ (mol dm^{-3})	K_s
0.0600	21	18.7	0.0187	0.0974	1.77×10^{-4}
0.0400	21	22.7	0.0227	0.0854	1.66×10^{-4}
0.0200	21	27.8	0.0278	0.0756	1.59×10^{-4}
-	21	34.2	0.0342	0.0684	1.60×10^{-4}

Answers to the questions:

