

Indian National Chemistry Olympiad 2016
Theory (3 hours)

Name: _____

Class: _____ Board: _____

Roll No. -- M/F: _____

I **permit/do not permit** (*strike out one*) HBCSE to make my INO academic performance and personal details public unless I communicate my consent in writing

I have read the Procedural Rules of the INOs and agree to abide by them.

Name of student: _____

Signature: _____ Place: _____ Date: January 30, 2016

Please Note:

- a) **Fill out the top half of the Performance card. Make sure that the performance card is attached to the question paper.**
- b) **Do not detach the performance card.**

Do not write anything below this line

Question No	1	2	3	4	5	Total
Marks	20	24	17	17	24	102
Marks Obtained						
Signature of Examiner						

Instructions for students

- Write your Name and Roll No. at the top of the first pages of all problems.
- This examination paper consists of **28** pages of problems including answer boxes.
- Kindly check that the booklet has all the pages.
- Total marks for INChO 2016 paper are **102**.
- You have 3 hours to complete all the problems.
- Blank space for rough work has been provided at the end of the paper.
- **Use only a pen to write the answers in the answer boxes. Anything written by pencil will not be considered for assessment.**
- All answers must be written in the appropriate boxes. Anything written elsewhere will not be considered for assessment.
- You **must** show the main steps in the calculations.
- Use only a non-programmable scientific calculator.
- For objective type question, mark **X** in the correct box. Some of the objective questions may have more than one correct answer.
- Values of fundamental constants required for calculations are provided on page 2.
- A copy of the Periodic Table of the Elements is provided at the end of the paper.
- Do not leave the examination room until you are directed to do so.
- The question paper will be uploaded on the HBCSE website on 2nd February 2016.

Fundamental Constants

Avogadro number	$N_A = 6.022 \times 10^{23} \text{ mol}^{-1}$
Electronic charge	$e = 1.602 \times 10^{-19} \text{ C}$
Molar gas constant	$R = 8.314 \text{ J K}^{-1} \text{ mol}^{-1}$ $= 8.314 \text{ K Pa} \cdot \text{dm}^3 \text{ K}^{-1} \text{ mol}^{-1}$ $= 0.082 \text{ L} \cdot \text{atm K}^{-1} \text{ mol}^{-1}$
1 atomic mass unit (1u)	$= 931.5 \text{ MeV}/c^2$
1 eV	$= 1.602 \times 10^{-19} \text{ J}$
1 cm^{-1}	$= 11.9 \times 10^{-3} \text{ kJ mol}^{-1}$
Rydberg constant	$R_H = 2.179 \times 10^{-18} \text{ J}$
Mass of electron	$m_e = 9.109 \times 10^{-31} \text{ kg}$
Planck's constant	$h = 6.625 \times 10^{-34} \text{ Js}$
Speed of light	$c = 2.998 \times 10^8 \text{ ms}^{-1}$
Acceleration due to gravity	$g = 9.8 \text{ ms}^{-2}$
Density of mercury	$= 13.6 \times 10^3 \text{ kg m}^{-3}$
Faraday constant	$F = 96485 \text{ C mol}^{-1}$
Temperature	$0^\circ\text{C} = 273.15 \text{ K}$

Name of Student

Roll No

Problem 1

20 Marks

Sulphate dynamics in Wastewaters

Wastewaters are one of the highly complex chemical systems in our environment. Understanding these complex chemical reactions is important for safe management of wastewater systems. Here we look at some of the chemical dynamics of sulphate ions in wastewaters. Under scarcity of stronger oxidizers such as O_2 and NO_3^- , SO_4^{2-} ions can act as oxidizing agents for organic matter in wastewater aiding its decomposition. Sulphate reduction is often facilitated by sulphate-reducing bacteria (SRB), which are usually present in sewage and thrive in an anaerobic (low oxygen) environment. Sulphate reduction can eventually lead to production of toxic H_2S gas. The overall redox reaction can be represented by the equation:

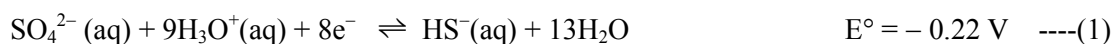

HS^- thus produced gets converted into H_2S .

In sewage, organic matter is present predominantly as suspended solid particles, which can be represented as $\{CH_2O\}$. This matter can act as food for SRB and as a reducing agent for sulphate. The chemical transformation in the process can be represented as

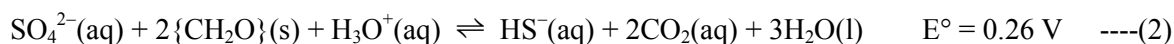

For all parts in this problem, take temperature of the system to be 298 K.

- 1.1 Determine the change in standard Gibbs free energy, ΔG° , for reaction (2) in kJ.

(1 mark)

- 1.2 Write an expression for equilibrium constant, K , for reaction (2) in terms of molar concentrations of the relevant chemical species.

(1 mark)

- 1.3 Calculate the value of K for reaction (2).

(1 mark)

- 1.4 A sewage entering a septic tank has $[\text{SO}_4^{2-}] = 0.5 \text{ mM}$ and $\text{pH} = 7.0$. Assuming (2) to be the predominant redox reaction in the sewage, determine the concentration of dissolved H_2S in it when the system reaches equilibrium. (For H_2S , $\text{pK}_{\text{a}1} = 7.0$ and $\text{pK}_{\text{a}2} = 11.96$).

Assume that

- H_2S and CO_2 gases produced remain in the solution phase.
- the carbonic acid produced here doesn't undergo dissociation.
- the sewage acts as buffer.

(2 marks)

Under aerobic conditions, CH_4 is also often produced in the decomposition of sewage in addition to H_2S and CO_2 .

- 1.5 Following graphs show temperature dependence of solubilities of the three gases in water, which includes the gas in dissolved form as well as its reaction products with water.

i) Label the boxes in each graph with appropriate gas.

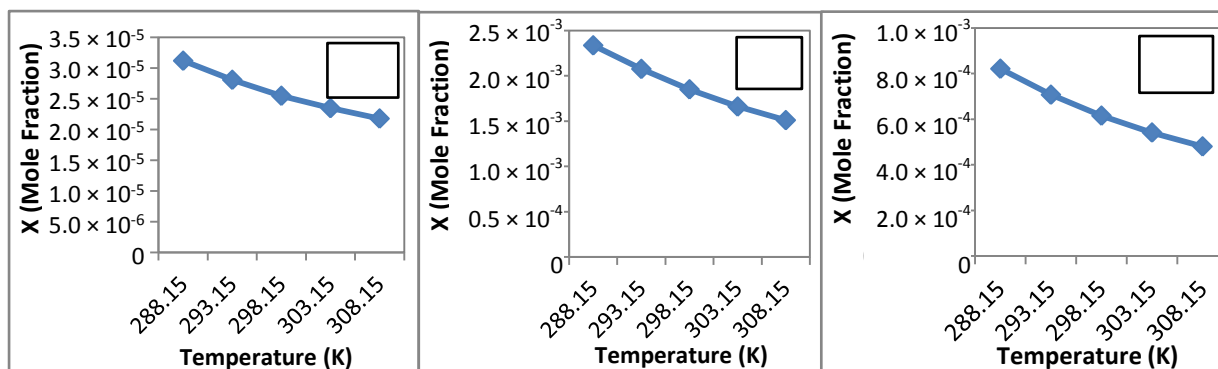

ii) Which of the three gases will escape from sewage the fastest?

(2 marks)

1.6 Septic tanks have a certain amount of air above the water level. In one such tank, the average composition of the air was found to be $N_2 = 86\%$, $O_2 = 9\%$, $H_2O = 1.5\%$, $CO_2 = 1.5\%$, $H_2S = 1\%$ and $CH_4 = 1\%$ (where the percentages are by mass). Calculate the average density of this air in $kg\ m^{-3}$, assuming its pressure to be 1 atm and all gases to be ideal.

(2 marks)

1.7 Unless there is turbulence or mixing, gases entering a chamber do not immediately diffuse uniformly in the chamber space. Initially they tend to accumulate in different horizontal zones according to their relative density compared to the air present in the chamber. Septic tanks are designed to have slow flow rate of sewage, therefore, do not have any significant turbulence in air inside. In the tank described in 1.6, indicate the zones in the air space (A, B, or C as shown below), in which each of the three gases (CH_4 , H_2S , CO_2) escaping from the sewage would accumulate initially.

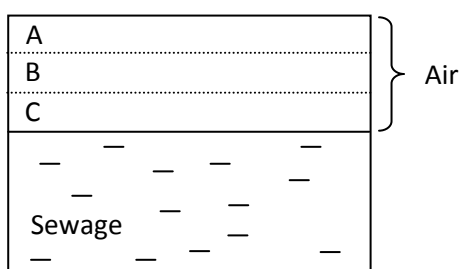

CH_4

CO_2

H_2S

(1.5 marks)

1.8 Water vapour in this air condenses on the tank walls. H_2S in the air then slowly dissolves in these droplets. Since oxygen is available in immediate vicinity of the droplets (because of high surface area to volume ratio as compared to sewage below), sulphur oxidizing bacteria (SOB) start accumulating in these droplets. In this new aqueous system, SOB oxidize sulphide species and produce sulphuric acid. The cement part in concrete walls can be represented as $(CaO)_3(Al_2O_3)$, which is attacked by sulphuric acid. Write the balanced reaction(s) responsible for sulphuric acid production in the water droplets and its possible reaction/s with the cement in concrete.



(1.5 marks)

Wastewater from tanneries contains high amounts of SO_4^{2-} and Cr(VI) species. Since Cr(VI) species are highly toxic, such wastewater is often treated with reducing agents such as sucrose to reduce Cr(VI) to Cr(III) before discharging. However, on exposure to air, Cr(III) species may get oxidized back to $\text{Cr}_2\text{O}_7^{2-}$.

- 1.9 A tannery wastewater containing 50 mg L^{-1} Cr(III) and 100 mg L^{-1} SO_4^{2-} having a $\text{pH} = 7.0$ is discharged in an open drain exposed to atmosphere. If atmospheric air contains 21.9% oxygen by mass, rest being predominantly nitrogen, calculate the ratio of $\text{Cr}_2\text{O}_7^{2-}$ to Cr(III) after it has attained equilibrium with the atmospheric air.

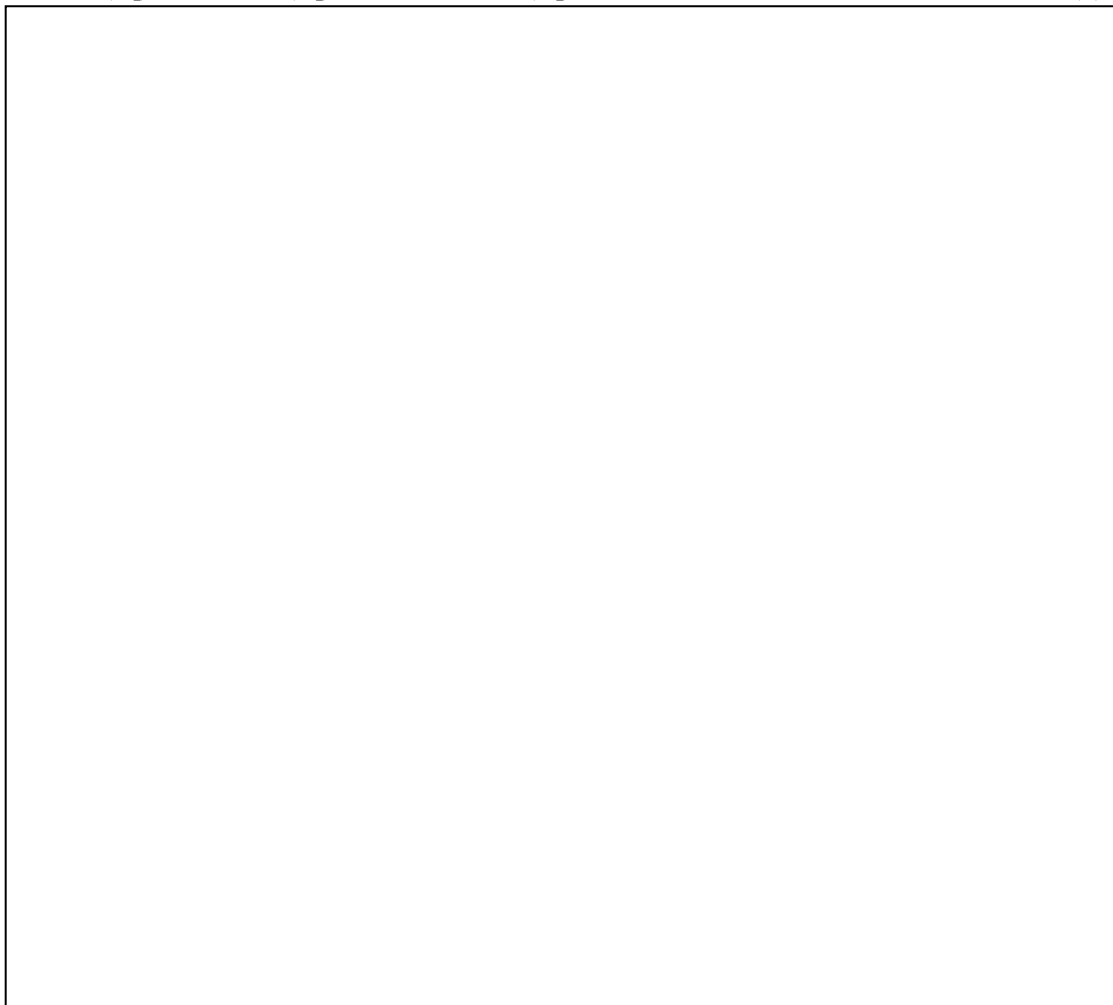
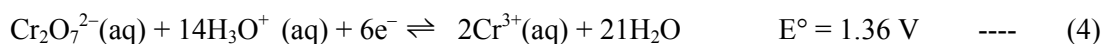

(4 marks)

As wastewater flow in open drains, its volume slowly decreases due to evaporation of water. In the open drain described in **1.9**, the water volume reduced by 30% on travelling 1 km.

- 1.10** Determine the equilibrium concentrations of SO_4^{2-} , Cr(III) and $\text{Cr}_2\text{O}_7^{2-}$ in the wastewater after this 1 km travel.

(1.5 marks)

After this 1 km stretch, the wastewater in **1.10** enters a closed sewer containing sewage, where oxygen is not available. Here, SRB would reduce sulphate to sulphide which can reduce $\text{Cr}_2\text{O}_7^{2-}$ back to Cr(III).

- 1.11** Write balanced chemical equations for the reactions and their standard electrochemical potentials which would determine the concentrations of Cr(III) and $\text{Cr}_2\text{O}_7^{2-}$ in this sewer, assuming they are solely driven by sulphate-sulphide inter-conversion.

(2.5 marks)

Name of Student

Roll No

Problem 2

24 Marks

Olefin Chemistry

Formation of carbon - carbon double bond (C=C) is important in organic synthesis as it provides a route for introduction of a wide range of functional groups in the resulting olefins. The geometric isomers of olefins are distinguished using stereodescriptors *E/Z*. If the two groups of higher priority, according to the Cahn – Ingold – Prelog rules, are on the opposite sides of the double bond, the configuration is *E*. The other configuration is *Z*.

2.1 Give the IUPAC name with stereochemical descriptor (*E/Z*) for the following compound.

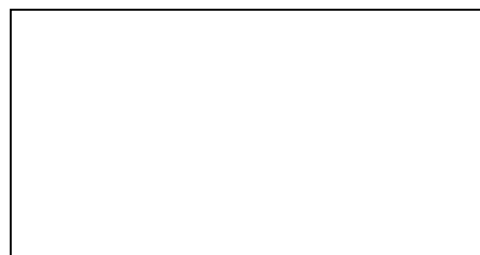
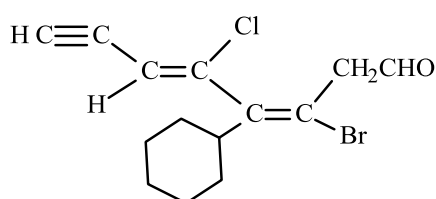

(2 marks)

One of the most widely used methods for the formation of C=C is β - elimination reaction of the following type.

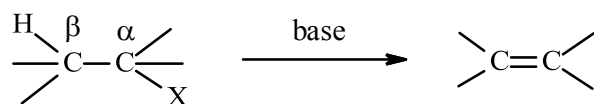

Where X= -Cl, -OCOR, $-\text{NR}_3^+$ etc.

The spatial arrangement for a bimolecular elimination (E_2) of the type shown above requires a *trans* geometry of the β - hydrogen and the leaving group (X). In most of the cases, the most substituted olefin is the favored product. However, in the case of ammonium and sulphonate salts, the least substituted olefin is formed as a major product.

2.2 Identify the major products **A-D** in each of the following reactions, indicating the correct stereochemistry wherever applicable.

i)

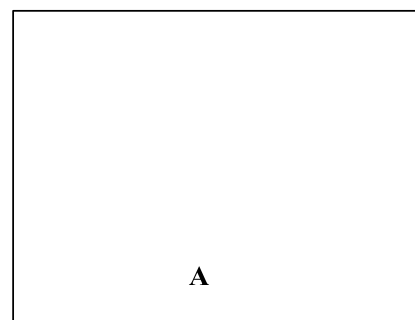
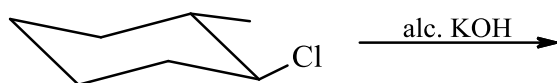

ii)

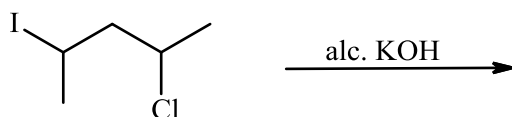

B

% C = 57.4

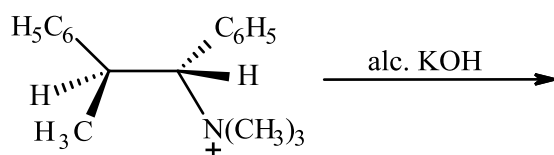
iii)

C

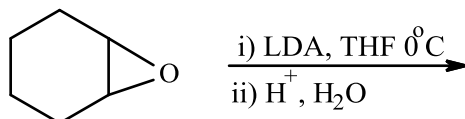
iv)

D

% C = 73.5 %H = 10.2

(2.5 marks)

Pyrolytic elimination is another synthetic route to generate alkenes. This reaction proceeds in a concerted manner through a cyclic transition state. The commonly used substrates in pyrolysis include carboxylate esters, sulfoxides, xanthates, etc. Such reactions proceed in a *syn* fashion, the hydrogen and the leaving group depart from the same side.

2.3 Identify the products **F-H** in the following reactions indicating the correct stereochemistry wherever applicable.

i)

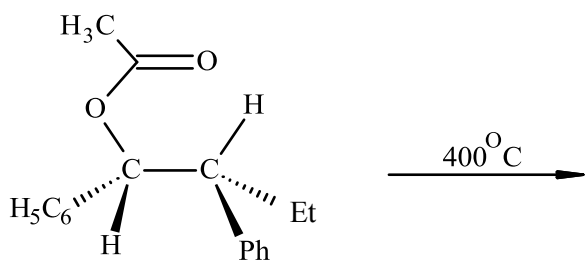
F

ii)

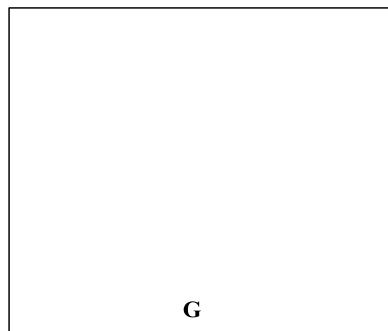
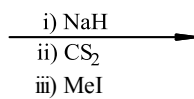
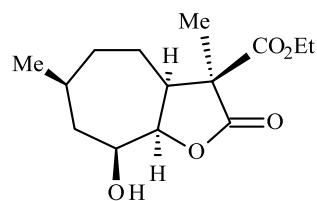

200°C

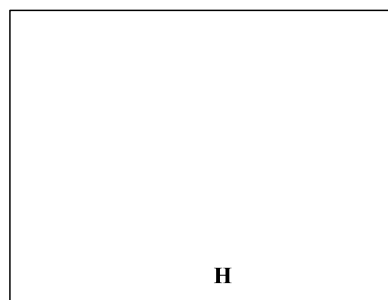

(3 marks)

Fragmentation reactions similar to β - elimination are useful for the preparation of olefins. One such reaction is shown below.

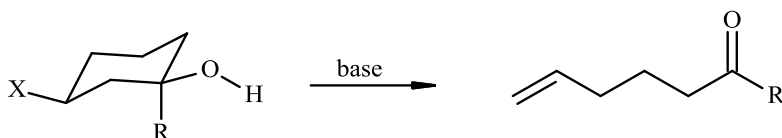

- 2.4 Identify the products **I-K** with proper stereochemistry, in the following reaction sequence which leads to an intermediate useful in the synthesis of the juvenile hormone, which regulates insect physiology.

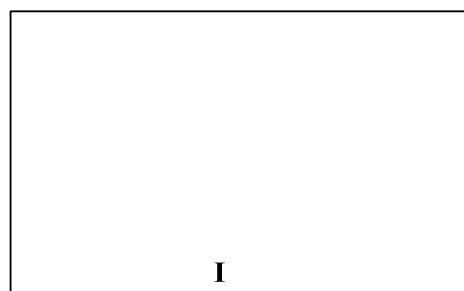
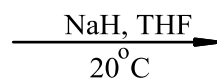
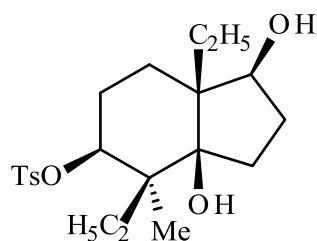

I

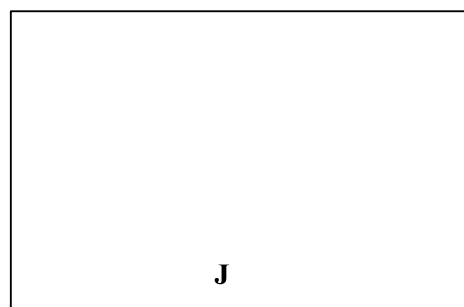
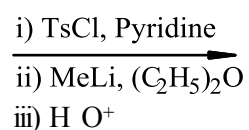



(3.5 marks)

One of the routes for the synthesis of *E* - olefins is the Julia olefination, where the starting compound is a sulfone having a good leaving group at the β - position.

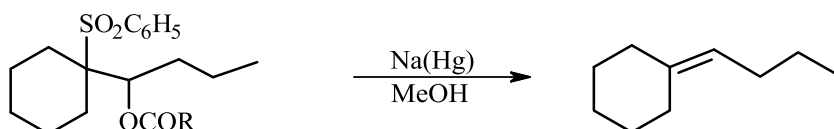

- 2.5 Sphingolipids are naturally occurring compounds which are believed to protect the cell surface from harmful environmental factors. Identify the products **L-N** in the following synthesis which yields the precursor of sphingosins, that forms the backbone of sphingolipids.

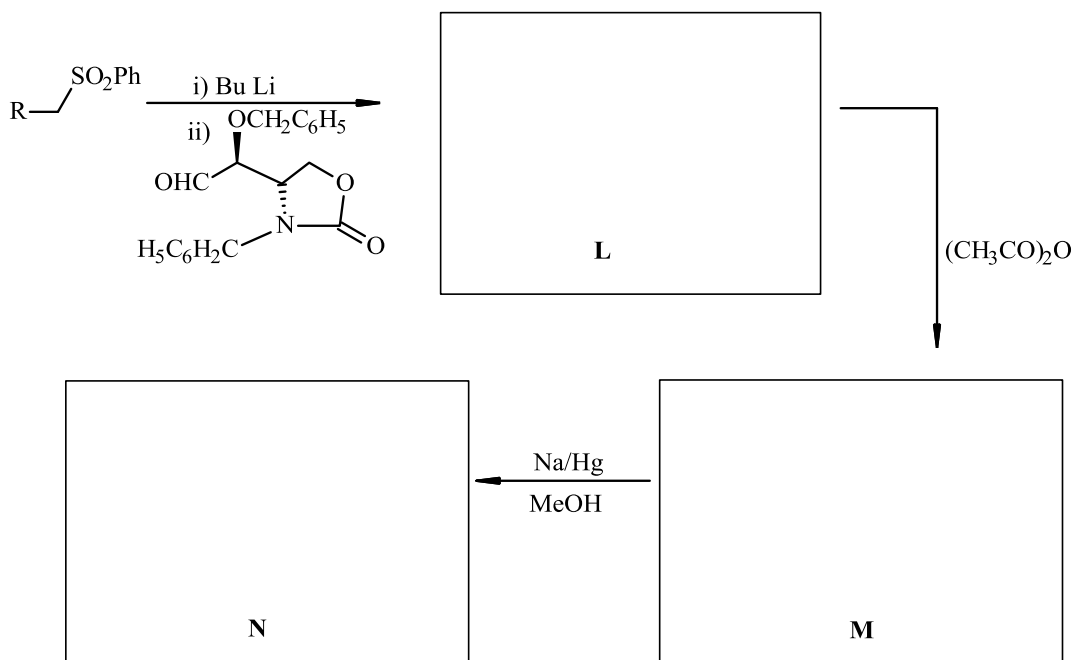

(2.5 marks)

Diboranes add readily to alkenes to give monoalkyl, dialkyl or trialkyl organoborane compounds. Organoboranes can be converted to C-O, C-N and C-C bonds via initial nucleophilic attack followed by rearrangement as illustrated below.

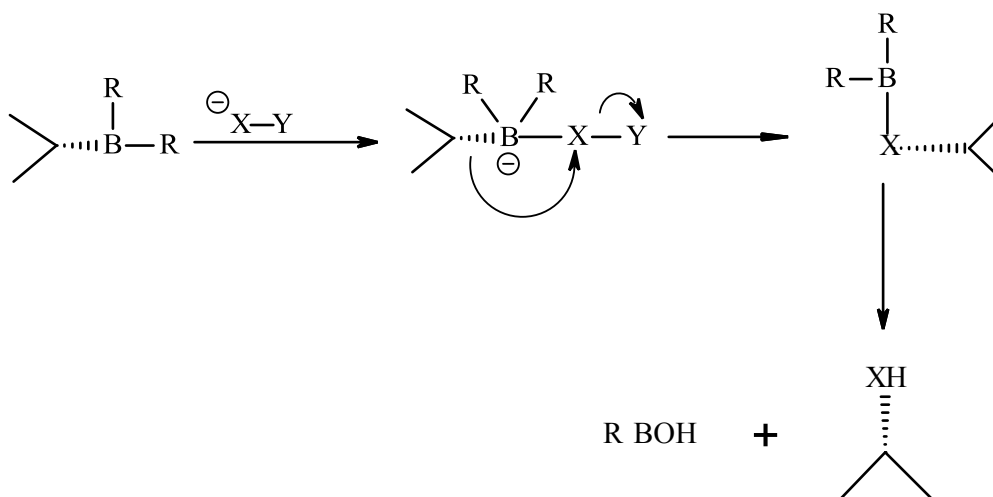

2.6 Complete the following reactions by identifying the compounds **O-Q**.

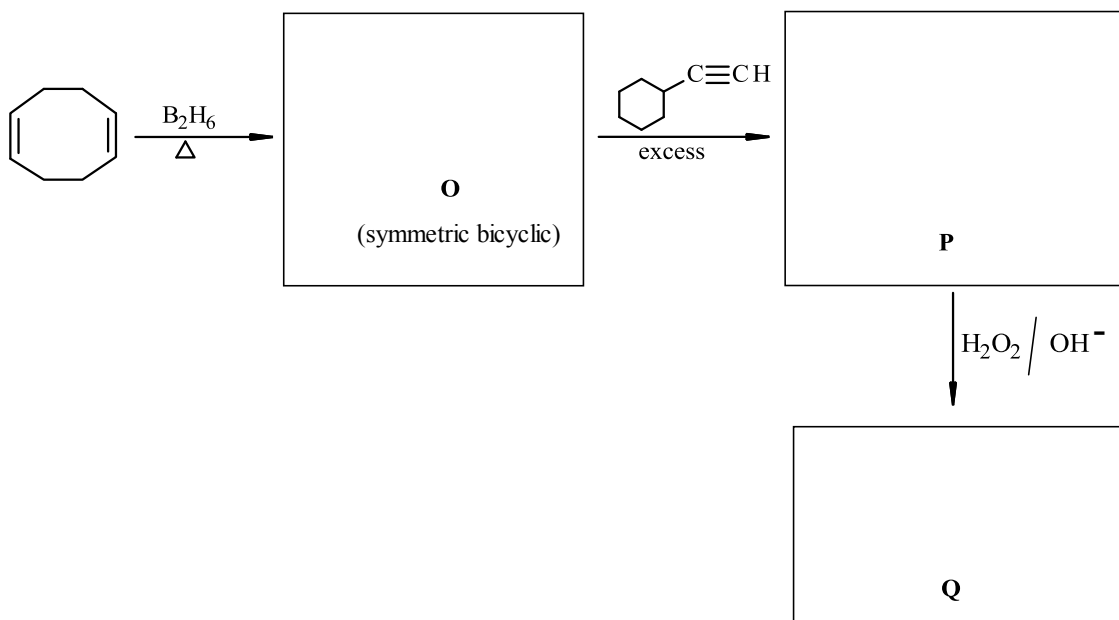

(3 marks)

2.7 Give the products **R-T** in the following reactions with correct stereochemistry wherever applicable.

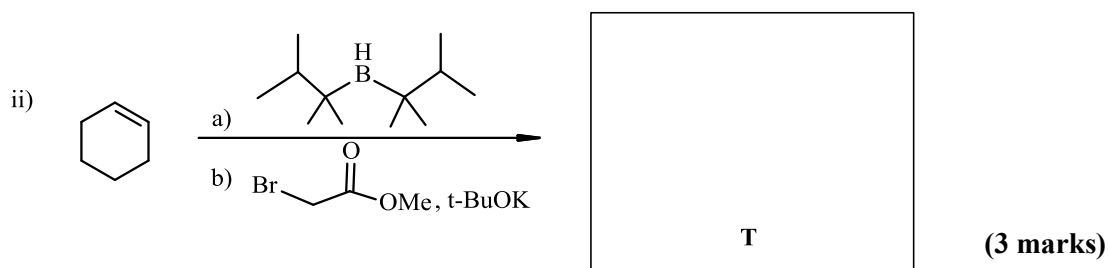
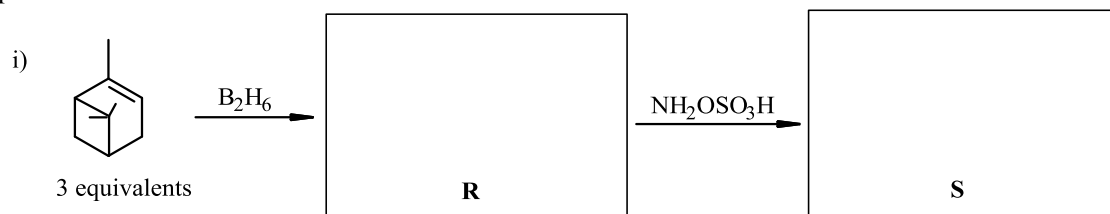

(3 marks)

While olefins are nucleophilic, presence of an electron withdrawing group attached to the olefinic carbon renders it electrophilic. Such olefins can undergo conjugate substitution reaction in the presence of good leaving groups at the β - position.

2.8 Give the product of the following reaction.

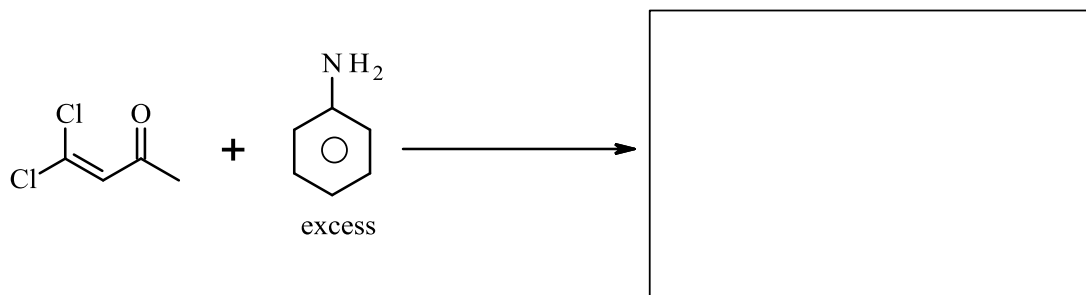

(1 mark)

2.9 Complete the synthesis of the anti - ulcer drug Tagamet, by identifying U-W.

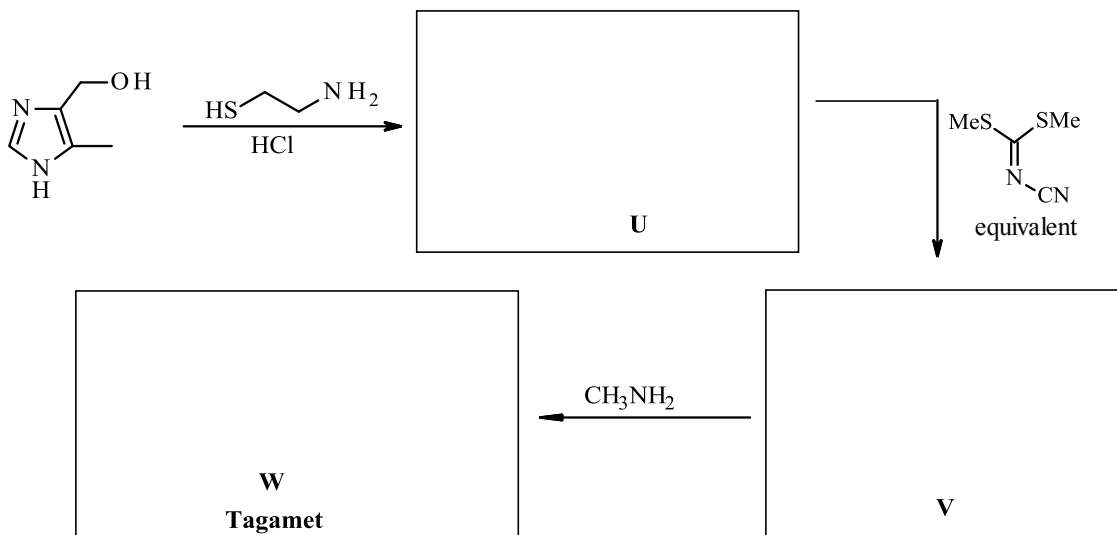

(3.5 marks)

Name of Student

Roll No

Problem 3

17 marks

Chemical Kinetics and Nuclear Reactions

Part A

The reaction between BrO_3^- and Br^- in acidic solution results in the formation of Br_2 and H_2O and the rate law is given by,

$$r = -\frac{d[\text{BrO}_3^-]}{dt} = k[\text{BrO}_3^-][\text{Br}^-][\text{H}^+]^2$$

3.1 Write the stoichiometric equation corresponding to this reaction.

(1 mark)

3.2 Write the total order of the reaction.

(1 mark)

3.3 Simplify the rate law for the same reaction if $[\text{BrO}_3^-]_0 = 2.5 \times 10^{-3} \text{ M}$, $[\text{H}^+]_0 = 1.0 \text{ M}$ and $[\text{Br}^-]_0 = 0.28 \text{ M}$ where the subscript zero refers to initial concentration.

(1 mark)

To study the kinetics of the above reaction, a student added phenol to the above reaction mixture, which undergoes the following reaction:

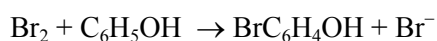

To detect the completion of the above monobromination reaction, the student added a drop of dilute methyl orange solution to the reaction flask. Methyl orange gets bleached by Br_2 and becomes colourless immediately even at very low Br_2 concentrations.

Monobromination of phenol, ($\text{C}_6\text{H}_5\text{OH}$) is a much faster reaction than the bromate-bromide reaction. The student prepared three reaction flasks as given in the table below. The student measured the time, t , it takes for the solution at different concentrations of phenol to turn colourless.

Flask No.	[C ₆ H ₅ OH] (M)	[Br ⁻] (M)	[H ⁺] (M)	[BrO ₃ ⁻]* (M)	Time taken for decolourization, <i>t</i> (sec)
1	4 × 10 ⁻³	0.28	1.0	2.5 × 10 ⁻³	11
2	2 × 10 ⁻³	0.28	1.0	2.5 × 10 ⁻³	4
3	1 × 10 ⁻³	0.28	1.0	2.5 × 10 ⁻³	1.5

*BrO₃⁻ is added in the last just before starting the experimental run.

3.4 On doubling the concentration of C₆H₅OH, (in the above table) *t* increased by more than a factor of two because (put X against the correct option/s)

- i) the decolouration reaction of methyl orange slowed down at higher concentration of phenol
- ii) the bromination of phenol slowed down at higher concentration of phenol
- iii) at higher concentration of phenol, BrC₆H₄OH started converting to Br₂C₆H₃OH
- iv) the rate of bromate-bromide reaction decreases with progress of reaction overtime.
- v) at higher concentration of phenol, the simplified rate law derived in 3.3 is no longer valid

(2 marks)

3.5 Calculate the rate constant, *k*, of bromate-bromide reaction using the data given in the above table. Show all important steps in the calculations.

(3 marks)

3.6 Another way to do this experiment is to keep the phenol concentration fixed and vary $[\text{BrO}_3^-]_0$. In such an experiment, (mark X against the correct option/s)

- (i) t will increase as $[\text{BrO}_3^-]_0$ increases
- (ii) k can be obtained from the initial slope of $[\text{BrO}_3^-]$ vs t plot fit to an exponential curve
- (iii) the experiment become less accurate as $[\text{BrO}_3^-]_0/[\text{C}_6\text{H}_5\text{OH}]_0$ decreases
- (iv) t will be independent of $[\text{Br}^-]_0$
- (v) k can be obtained using the slope of $1/t$ vs $[\text{BrO}_3^-]$ plot fit to a line

(2 marks)

Part B

3.7 Radioactive $^{238}\text{U}_{92}$ emits alpha and beta particles and forms stable $^{206}\text{Pb}_{82}$.

i) Write the balanced overall nuclear reaction.

(1 mark)

ii) An uranium ore sample is found to contain 1.19 g of $^{238}\text{U}_{92}$ and 1.03 g of $^{206}\text{Pb}_{82}$. (Assume that there was no lead initially in the ore).

a) What mass of helium has escaped from the ore sample?

(1 mark)

b) How old is the ore? Half of $^{238}\text{U}_{92}$ converts to $^{206}\text{Pb}_{82}$ in 1.0 billion years.

(1 mark)

3.8 $^{239}\text{U}_{92}$ decays to ^{239}Pu through the formation of an intermediate nucleus ^{239}Np , the successive decay constants being k_1 and k_2 .

i) Write the rate equation for decay of both ^{239}U and ^{239}Np .

(1.5 marks)

The concentration of ^{239}Np can be expressed by the following expression.

$$[^{239}\text{Np}] = \frac{k_1[^{239}\text{U}]}{k_2 - k_1} (e^{-k_1 t} - e^{-k_2 t})$$

ii) Simplify the expression using suitable approximation if the half lives for the decay of the two nuclei are 23.5 minutes and 2.35 days, respectively.

(1mark)

iii) Following graph shows the concentration profiles for U, Np and Pu as a function of time. Label each curve with the corresponding species.

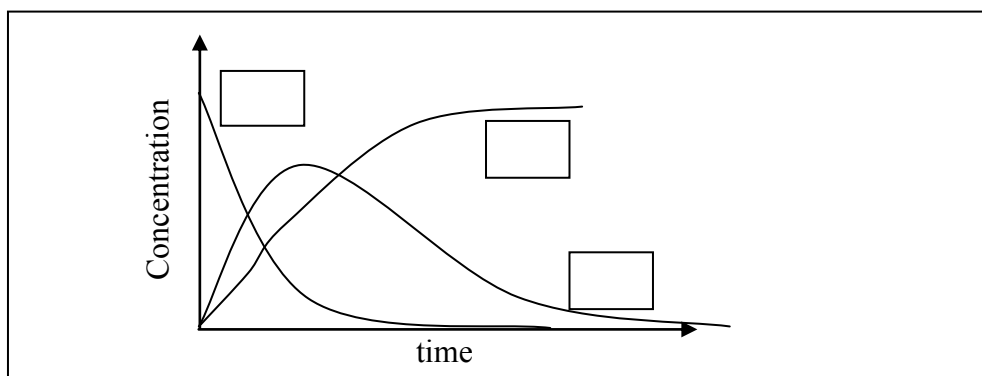

(1mark)

iv) State whether the following statement is true or false.

Nuclear disintegration rate approximately doubles for every 10°C rise in temperature.

(Mark **X** the appropriate choice).

True

False

(0.5 mark)

Name of Student

Roll No

Problem 4

17 Marks

Synthesis of Natural Products

Nonconjugated dienes are important intermediates in natural product synthesis. One of the simple ways to synthesize these compounds is outlined below.

4.1 Identify products **A** and **B** in the following synthesis of a 1,4 diene.

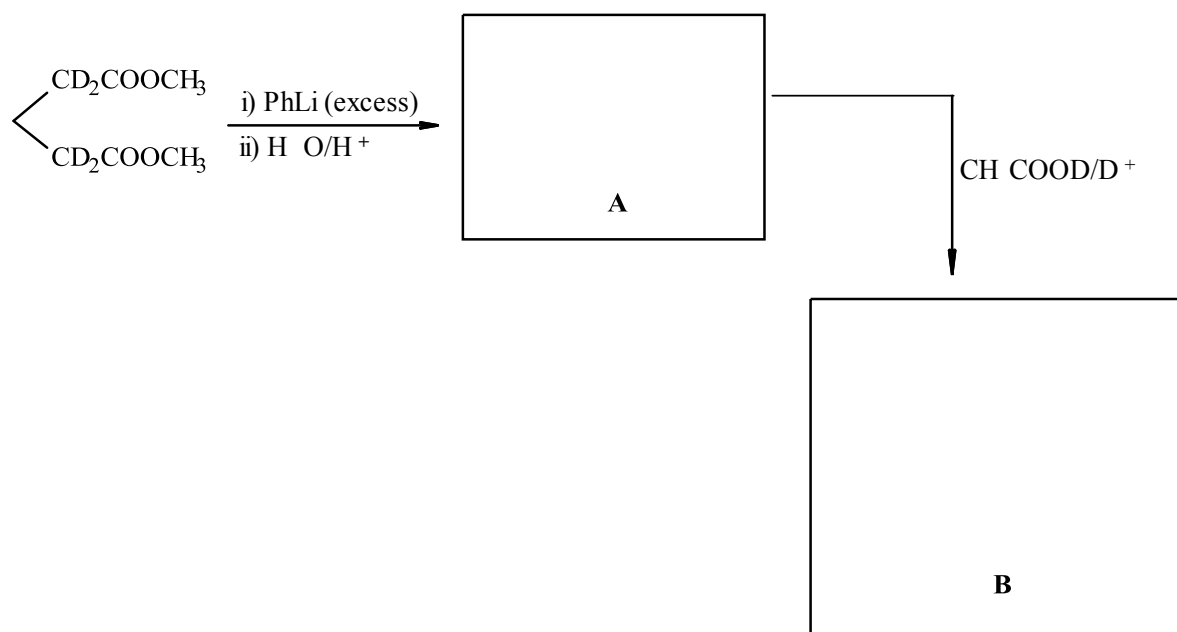

(1.5 marks)

Di-pi methane rearrangement is an important photochemical reaction in which nonconjugated dienes form an ene-substituted cyclopropane, as shown below.

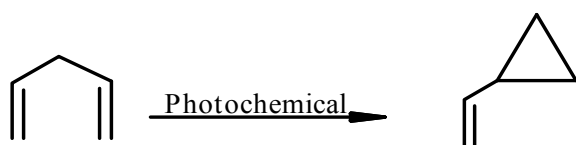

Zizaene is a naturally occurring terpene found in vetiver oil and used for the synthesis of α - vetivone that is used in perfumeries. It is prepared from compound **C**.

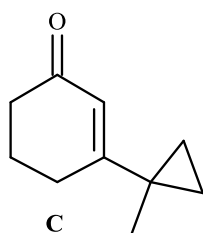

- 4.2 Draw the structure of the precursor of **C**, if it was to be prepared by the di-pi methane rearrangement.

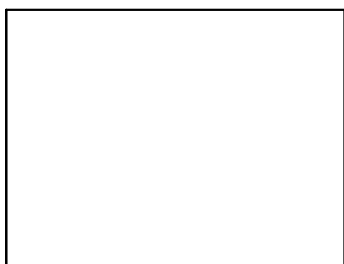

(1 mark)

Vinyl cyclopropane to cyclopentene rearrangement (shown below) is an important method for the synthesis of five membered carbocycles. This rearrangement can be performed under thermal, photochemical or catalytic activation. Under thermal and photochemical conditions, this rearrangement proceeds via formation of the most stable biradical.

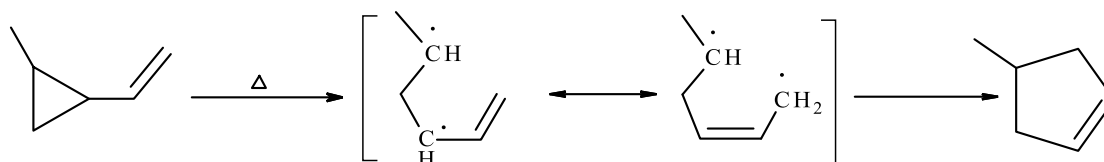

The vinyl cyclopropane rearrangement is a key step in the synthesis of Zizaene. The synthesis of Zizaene is outlined below.

- 4.3 Draw the structures of **D** – **F** in the following reaction sequence.

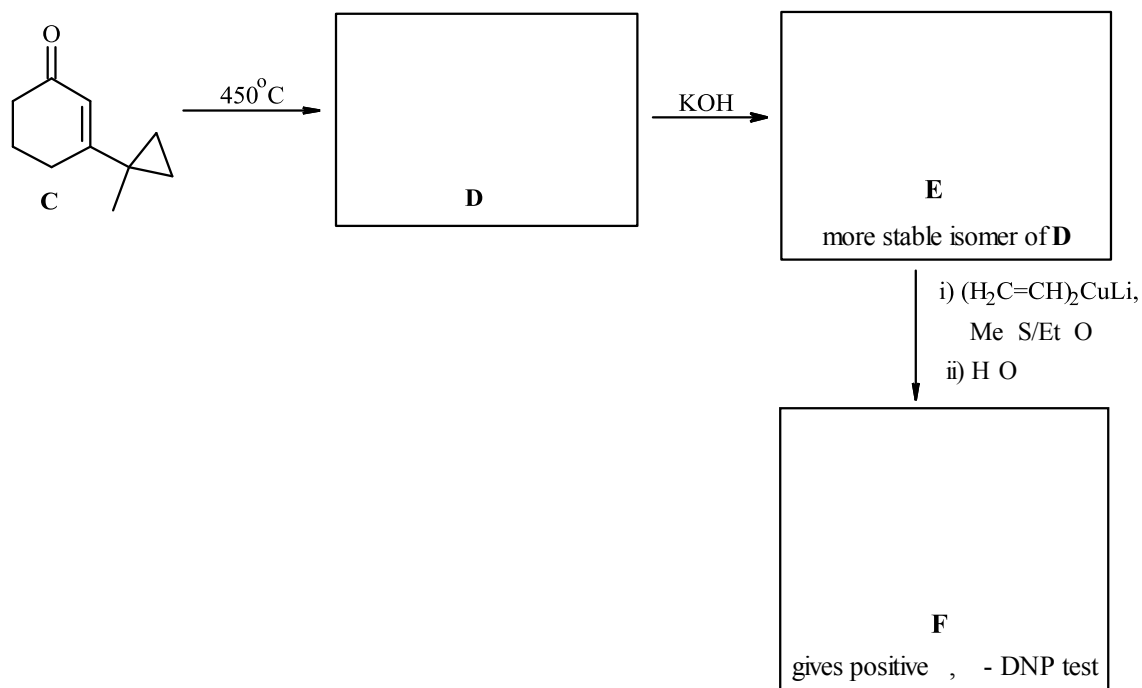

(2.5 marks)

Compound **F** on reaction with $\text{LiN}(\text{i-Pr})_2$ (**LDA**) (LDA is a bulky base) and PhS-SPh gives compound **G**, which on further oxidation using NaIO_4 gives intermediate **H** and product **I**.

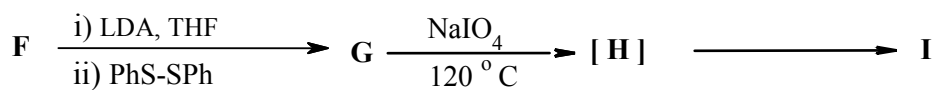

4.4 Identify **G**, **H** and **I**.

G	H Intermediate	I % C = . % H = .
----------	--------------------------	--------------------------------

(2 marks)

4.5 Draw the structures of **J** and **K** in the following reaction.

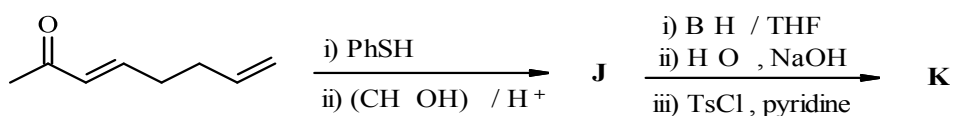

J	K
----------	----------

(3 marks)

Compound **N** is an intermediate for the synthesis of Zizaene. It is synthesized as shown below.

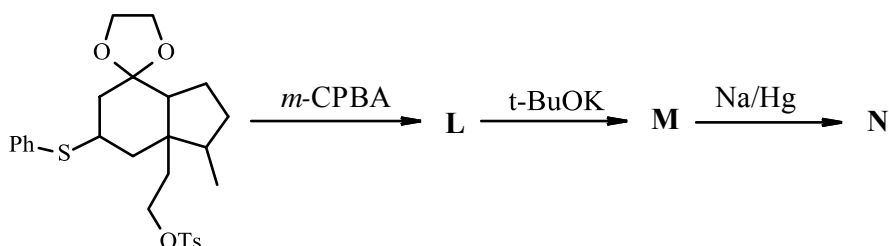

4.6 Identify L, M and N.

<p>L</p> <p>%C = . %H = . %O = .</p>	<p>M</p>	<p>N</p> <p>%C = . %H = .</p>
---	-----------------	---

(3.5 marks)

Ylide is a species with a positive charge on a hetero atom and a negative charge on the adjacent carbon atom. Wittig reaction is a reaction which involves the phosphorous ylide.

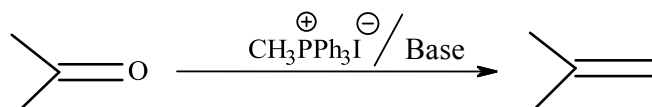

4.7 Identify O and P. Draw the structure of Zizaene.

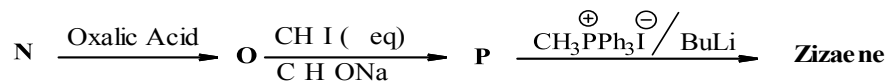

<p>O</p>	<p>P</p>	<p>Zizaene</p>
-----------------	-----------------	-----------------------

(3 marks)

4.8 How many stereocenters does Zizaene have?

(0.5 marks)

Name of Student

Roll No

Problem 5

24 Marks

Nickel and its chemistry

Commercially important nickel ores include its sulfide, which also contains iron (II) and copper (I) sulfides. The concentrated ore is smelted in presence of silica which helps in removal of iron as slag (Step I). The upper silvery layer of Cu_2S and lower black layer of Ni_2S_3 remaining with the ore are then mechanically separated. The Ni_2S_3 is roasted in air to give a green solid (Step-II), which on subsequent treatment with water gas (mixture of CO and H_2 gas) at 50°C gives a volatile complex and other byproducts (Step-III). This complex on thermal decomposition in air at 230°C gives pure solid Ni (Step-IV).

5.1 i) Write the balanced chemical equations for Steps I – IV.

Step I: Step II: Step III: Step IV:
--

(2.5 marks)

ii) Which of the following statements is / are true for Step III (Mark X in the correct box/es):

- | | |
|--|--------------------------|
| a) Only H_2 from water gas reacts with Ni ions and reduces it | <input type="checkbox"/> |
| b) H_2 from water gas reduces Ni ions and then CO complexes with the reduced form of Ni | <input type="checkbox"/> |
| c) Only CO from water gas reduces Ni ions | <input type="checkbox"/> |
| d) Both CO and H_2 from water gas act as reducing agents | <input type="checkbox"/> |

(1mark)

Pure nickel forms alloys with various metals such as As, Al, Cd, Cr, Zn etc. and some of these have well defined crystal structure. The unit cell of Ni_xAs_y is shown in the following figure.

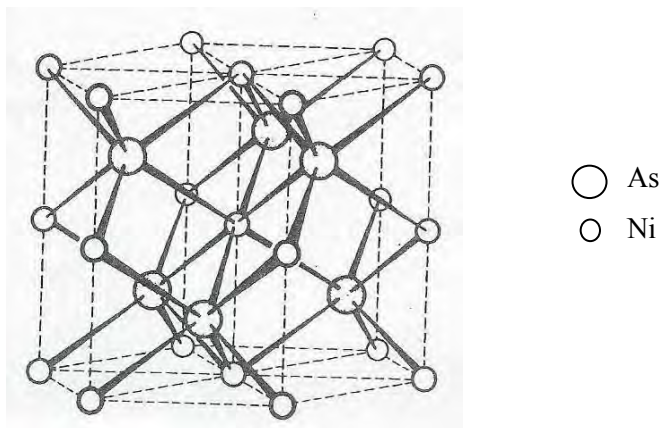

Diagram sourced from *Structural Inorganic Chemistry*, A F Wells, 5th Reprint edition, 2012, Oxford University Press, Oxford.

- 5.2 i) Using the above diagram identify the coordination number and geometries of Ni and As. (Mark **X** in the correct box)

Element	Coordination No.		Coordination geometry			
	6	4	Octahedral	Trigonal Prismatic	Square planar	Tetrahedral
Ni	<input type="checkbox"/>	<input type="checkbox"/>	<input type="checkbox"/>	<input type="checkbox"/>	<input type="checkbox"/>	<input type="checkbox"/>
	<input type="checkbox"/>	<input type="checkbox"/>	<input type="checkbox"/>	<input type="checkbox"/>	<input type="checkbox"/>	<input type="checkbox"/>
As	<input type="checkbox"/>	<input type="checkbox"/>	<input type="checkbox"/>	<input type="checkbox"/>	<input type="checkbox"/>	<input type="checkbox"/>
	<input type="checkbox"/>	<input type="checkbox"/>	<input type="checkbox"/>	<input type="checkbox"/>	<input type="checkbox"/>	<input type="checkbox"/>

(2 marks)

- ii) Find the values of x and y in Ni_xAs_y .

x =	y =
-----	-----

(0.5 mark)

Nickel forms various alloys such as stainless steel, nichrome and cupranickel which have various applications in industries.

Stainless steel has the following approximate composition (w/w): 73% Fe, 18% Cr and 8% Ni. An industrial sample of stainless steel was analyzed for its nickel content using chemical methods. One of the standard quantitative methods for estimation of nickel utilizes two moles of

chelating bidentate ligand, dimethylglyoxime [DMG, $\text{CH}_3\text{C}(\text{NOH})\text{C}(\text{NOH})\text{CH}_3$]. Nickel precipitates as a neutral complex ($\text{C}_8\text{H}_{14}\text{O}_4\text{N}_4\text{Ni}$), dark pink in color.

- 5.3 i) Draw the structure of the complex formed.



(1 mark)

1.4 g of stainless steel sample was treated with aqua-regia to dissolve all the contents of the sample. The solution was treated for removal of iron and chromium ions and was then diluted to 100 mL using distilled water. 10 mL of this diluted solution when treated with DMG gave 0.0532 g of the precipitate of the complex.

- ii) Calculate the % of nickel in the sample taken for analysis. Show all important steps of calculations.



(2 marks)

The stability of nickel complexes can be understood from their formation constant, K . The formation constants of the following Ni complexes **X** and **Y** at 25 °C are



- 5.4 i) Draw the structure/s of all possible isomers of **Y** and **encircle** the optically active isomer/s if any.

(2 marks)

- ii) Calculate the entropy change during the formation of **Y** in Equation II at 25 °C, if the heat of reaction for Equation II at constant pressure is $-12.1 \text{ kJ mol}^{-1}$.

(2 marks)

Raney nickel is a versatile hydrogenation catalyst. It is prepared by leaching out Al selectively from Ni-Al alloy powder under controlled condition by treating with concentrated solution of caustic soda. The slurry of finely divided spongy nickel particles is thus obtained which is then washed with large quantities of water to make the particles free from caustic soda.

- 5.5 Write balanced chemical equation for leaching process during the preparation of catalyst.

(1 mark)

Green nickel oxide NiO can be doped with colorless lithium oxide, Li_2O , to give a black solid $\text{Li}_x\text{Ni}_{1-x}\text{O}$ which acts as a semiconductor.

- 5.6 Which of the following statement(s) is/are correct for the above observations? (Mark **X** in the correct box)

- i) $\text{Li}_x\text{Ni}_{1-x}\text{O}$ exhibits both cationic and anionic vacancies
- ii) $\text{Li}_x\text{Ni}_{1-x}\text{O}$ exhibits Schottky defect
- iii) Doping of NiO with lithium induces mixed valency of nickel
- iv) NiO becomes a p-type semiconductor

(1mark)

Mixed metal oxides of transition metals often form spinels having the general formula $A^{II}B^{III}_2O_4$ where the oxide ions form a close packed cubic lattice with eight tetrahedral holes and four octahedral holes per $A^{II}B^{III}_2O_4$ unit. In a normal spinel $1/8^{\text{th}}$ of the tetrahedral holes are occupied by A (II) whereas B (III) resides in octahedral sites. In inverse spinel A (II) and one half of B (III) occupy the octahedral holes while the other half of B (III) occupy the tetrahedral holes. The structure becomes ‘normal’ ($A^{II}B^{III}_2O_4$) or ‘inverse’ spinel ($B^{III}A^{II}B^{III}O_4$) depending upon the octahedral site preference energy which is the difference of the crystal field stabilization energy (CFSE) of the same cation in the corresponding octahedral and tetrahedral field of the ligand.

Metal ion	Δ_0 (cm ⁻¹)	Δ_t (cm ⁻¹)
Co ³⁺	20,760	9,226
Fe ³⁺	14,000	6,220
Ni ²⁺	8,500	3,780

(Δ_0 and Δ_t imply the octahedral and tetrahedral splitting parameters respectively for oxide ions which will provide a moderately weak field similar to that of water)

5.7 On the basis of the above data, calculate the CFSE for

- Case I: i) Co(III) in octahedral ii) Co(III) in tetrahedral sites
 Case II: i) Fe (III) in octahedral ii) Fe(III) in tetrahedral sites
 Case III: i) Ni(II) in octahedral ii) Ni(II) in tetrahedral sites

(Calculations involving pairing energies can be neglected for this question and only CFSE values can be calculated)

Case I
Case II
Case III

(2.5 marks)

iii) Calculate the octahedral site preference energy from 5.7 for all the above three cases.

Case I
Case II
Case III

(1 mark)

iv) Based on the above octahedral site preference energy calculations, classify the oxides as normal and inverse spinels. (Mark X in the correct box)

Compound	Normal	Inverse
NiFe ₂ O ₄		
NiCo ₂ O ₄		

(1 mark)

5.8 One of the widely used batteries of nickel is Ni-Cd battery. This battery uses high purity NiOOH (nickel oxyhydroxide) as anode. The typical synthesis of NiOOH is as follows.

In the first step, concentrated NaOH (30% w/v) is reacted with gaseous Cl₂ for sufficient time to generate hypochlorite.

i) Write balanced chemical equation for this reaction.

(0.5 mark)

The resultant reaction mixture is then treated with excess of solid NaOH with vigorous stirring which leads to precipitation of NaCl. The precipitate is filtered and the sufficient amount of Ni(OH)₂ is added to the filtrate with constant stirring. Black colored NiOOH is formed as suspension.

ii) Write the balanced chemical equation that leads to formation of NiOOH.

(1 mark)

The NiOOH suspension thus obtained is filtered and dried appropriately. However, before its use, it needs to be analyzed for its purity.

In one such analysis, 0.520 g of NiOOH sample prepared by the above method was treated with 25 mL of acidified 0.305 M Fe (II) solution. On dissolution, Fe(II) ions get oxidized quantitatively by Ni ions. The unreacted Fe(II) was titrated with 0.0285 M of KMnO_4 under acidic condition and the observed reading was 15.1 mL.

5.9 Write balanced chemical equations for-

- i) Reaction of NiOOH with acidified Fe(II)
- ii) Reaction involved in titration with KMnO_4

i)
ii)

(1 mark)

- iii) Calculate the percentage of NiOOH in the sample taken for analysis. Show the main steps of calculations.

--

(2 marks)