

## Theoretical Problems

### Notes:

*Give your solutions and answers only on the answer sheets.*

*Begin, when the bell rings.*

*The total time for you is 5 hours.*

### Problem 1

1. Excavated Chinese ancient bronze musical instrument, carillon, was covered entirely by rust. Chemical analysis showed that the rust contains  $\text{CuCl}$ ,  $\text{Cu}_2\text{O}$  and  $\text{Cu}_2(\text{OH})_3\text{Cl}$ . Simulation experiments showed that  $\text{CuCl}$  was formed first under the action of both air and  $\text{Cl}^-$  containing aqueous solution and then  $\text{Cu}_2(\text{OH})_3\text{Cl}$  produced through the following two different ways:

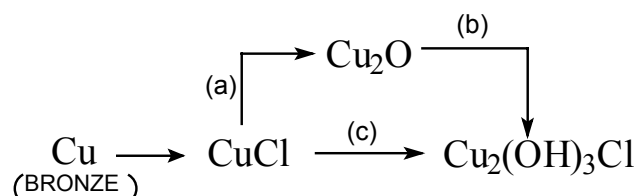

Given the molar standard formation Gibbs free energies of the species concerned, answer the following questions:

Species	$\text{Cu}_2\text{O}(\text{s})$	$\text{CuO}(\text{s})$	$\text{CuCl}(\text{s})$	$\text{Cu}_2(\text{OH})_3\text{Cl}(\text{s})$	$\text{Cl}^-(\text{aq})$	$\text{OH}^-(\text{aq})$	$\text{H}_2\text{O}(\text{l})$
$\frac{\Delta_f G_m^\ominus(298\text{K})}{\text{kJ}\cdot\text{mol}^{-1}}$	-146	-130	-120	-1338	-131	-157	-237

- i) Write balanced equations for reactions (a), (b) and (c).
  - ii) Calculate the molar standard Gibbs free energy  $\Delta_r G_m^\ominus(298\text{K})$  for reactions (a), (b) and (c).
  - iii) Decide the spontaneous direction of reaction (a) in air through calculation, when  $T = 298\text{K}$ ,  $C_{\text{HCl}} = 1.0 \times 10^{-4} \text{ mol}\cdot\text{dm}^{-3}$ .
2. Rate constants  $k_c$  for reaction (c) were measured at various temperatures in a simulation experiment in order to obtain its kinetic parameters. On the basis of the data given below, answer the following questions.

$t/^\circ\text{C}$	25	40
$k_c / \text{mol}\cdot\text{dm}^{-3}\cdot\text{s}^{-1}$	$1.29\times 10^{-4}$	$2.50\times 10^{-4}$

i) Write the equation for calculating the activation energy of reaction (c) and find the value.

ii) Assign the overall reaction order of reaction (c).

iii) Knowing that the rate determining step of reaction (c) is the monolayer adsorption of  $\text{O}_2$  (g) on solid  $\text{CuCl}$ , write the overall rate equation of this heterogeneous reaction (c). Under what condition might the reaction order be the same as that you have given in ii)? Assume only  $\text{O}_2$  can be adsorbed.

3. A copper plate was divided into two parts, Cu(1) and Cu(2). Cu(1) was then hammered so that Cu(1) and Cu(2) are different in certain thermodynamic properties.

i) An electromotive cell with Cu(1) and Cu(2) was designed as  $\text{Cu(1)}|\text{CuSO}_4(\text{aq})|\text{Cu(2)}$  and the electromotive force  $E$  of the above cell was expressed as  $E = \phi_{\text{R}} - \phi_{\text{L}}$ , where  $\phi_{\text{R}}$  and  $\phi_{\text{L}}$  being the right and left electrode potentials (i. e. half-cell potentials), respectively. Please choose the correct  $E$  value from the following and give the thermodynamic reason for your choice.

(A)  $E < 0$       (B)  $E = 0$       (C)  $E > 0$       (D) can not decide

ii) Write the net cell reaction for the cell.

4. In a Cu–Zn alloy the molar fractions of Cu and Zn are 0.750 and 0.250, respectively. The structure type of the alloy is the same as that of pure copper, except Zn atoms substitute some Cu atoms randomly and statistically, i. e. at every atomic position, the probability of the occupation of Cu and Zn is proportional to the composition of the alloy. In this sense the alloy can be considered as composed of statistical atoms  $\text{Cu}_x\text{Zn}_{1-x}$ . X-ray analysis shows that the arrangement of atoms in the alloy is of the cubic face-centered close packing type. Density of the alloy  $d = 8.51 \text{ g}\cdot\text{cm}^{-3}$ . Calculate the radius of the statistical atoms in the alloy.

Given:  $A_{\text{r}}(\text{Cu}) = 63.5$ ,  $A_{\text{r}}(\text{Zn}) = 65.4$ .

## Problem 2

To control the quality milk serum, a dairy by-product, the concentration of  $\text{NO}_3^-$  ion in serum is monitored by means of an ion selective electrode.

Generally there is about  $15 \text{ mg NO}_3^-$  ion per liter in serum, measured on the basis of nitrogen mass.

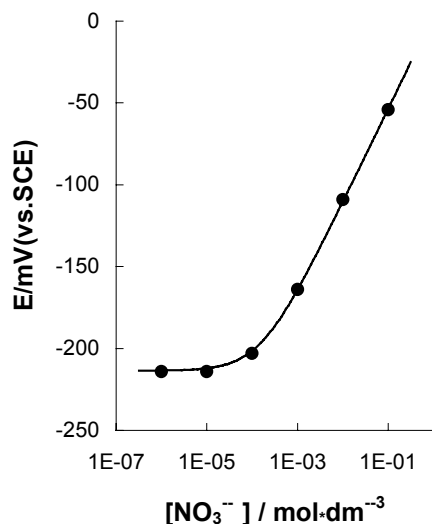

1. For a nitrate ion selective electrode a calibration curve as shown left was obtained using a series of standard nitrate solutions containing  $0.5 \text{ mol}\cdot\text{dm}^{-3} \text{ K}_2\text{SO}_4$ ,  $1.0 \times 10^{-3} \text{ mol}\cdot\text{dm}^{-3} \text{ H}_2\text{SO}_4$  and  $2.6 \times 10^{-3} \text{ mol}\cdot\text{dm}^{-3} \text{ Cl}^-$  ion as the background. Decide whether it is feasible to measure  $\text{NO}_3^-$  concentration in serum under the above conditions.

2. Given the selective coefficients of  $\text{Cl}^-$ ,  $\text{SO}_4^{2-}$  and  $\text{ClO}_4^-$  versus  $\text{NO}_3^-$  as follows:

$$K_{\text{NO}_3^-, \text{Cl}^-} = \frac{C_{\text{NO}_3^-}}{C_{\text{Cl}^-}} = 4.9 \times 10^{-2}; \quad K_{\text{NO}_3^-, \text{SO}_4^{2-}} = \frac{C_{\text{NO}_3^-}}{C_{\text{SO}_4^{2-}}^{1/2}} = 4.1 \times 10^{-3}; \quad K_{\text{NO}_3^-, \text{ClO}_4^-} = \frac{C_{\text{NO}_3^-}}{C_{\text{ClO}_4^-}} = 1.0 \times 10^{-3}$$

where the units of the concentrations are in  $\text{mol}\cdot\text{dm}^{-3}$ , which is the best to reduce the interference of  $\text{Cl}^-$  to  $\text{NO}_3^-$  determination, so as to control the error in the  $\text{NO}_3^-$  concentration within 1%, when there are  $1.40 \times 10^{-3} \text{ mol}\cdot\text{dm}^{-3} \text{ NO}_3^-$  and  $1.60 \times 10^{-2} \text{ mol}\cdot\text{dm}^{-3} \text{ Cl}^-$  in serum:

(A)  $\text{AgNO}_3$

(B)  $\text{Ag}_2\text{SO}_4$

(C)  $\text{AgClO}_4$

Calculate the amount of the salt that should be added to  $1 \text{ dm}^3$  of the sample solution to be measured.

3. The  $\text{NO}_3^-$  ion concentration was determined by this method at 298K. For

25.00 cm<sup>3</sup> sample solution, the electric potential,  $E$ , is measured to be  $-160$  mV.

After adding 1.00 cm<sup>3</sup>  $0.100 \times 10^{-2}$  mol·dm<sup>-3</sup> NO<sub>3</sub><sup>-</sup> standard solution to the above solution,  $E$  changes to  $-130$  mV. Find the pNO<sub>3</sub> of the serum.

4. The selective coefficient of CH<sub>3</sub>COO<sup>-</sup> versus NO<sub>3</sub><sup>-</sup> is

$K_{\text{NO}_3^-, \text{CH}_3\text{COO}^-} = 2.7 \times 10^{-3}$ . If AgCH<sub>3</sub>COO instead of Ag<sub>2</sub>SO<sub>4</sub> is added to the sample solution of question 2, find the upper limit of the pH value, below which the same requirement in question 2 can be met.

$$K_{\text{sp}}(\text{AgCl}) = 3.2 \times 10^{-10}$$

$$K_{\text{sp}}(\text{Ag}_2\text{SO}_4) = 8.0 \times 10^{-5}$$

$$K_{\text{sp}}(\text{AgCH}_3\text{COO}) = 8.0 \times 10^{-3}$$

$$K_{\text{a}}(\text{CH}_3\text{COOH}) = 2.2 \times 10^{-5}$$

$$A_{\text{r}}(\text{N}) = 14.00$$

### Problem 3

1,3-Dihydroxyacetone can be converted to glyceraldehyde. On standing this glyceraldehyde changes spontaneously into a six member cyclic dimer C<sub>6</sub>H<sub>12</sub>O<sub>6</sub>. The infrared spectrum of the dimer shows no absorption peak between 1600—1800 cm<sup>-1</sup> and the dipole moment of the dimer is determined to be zero.

1. Write the Fischer projection structural formula(e) for the resulting glyceraldehyde and indicate configuration using D(+) and/or L(-).
2. Write the structural formula for the reaction intermediate of the conversion of 1,3-dihydroxyacetone to glyceraldehyde.
3. Write the structural formula for the dimer.
4. Using Haworth projection formula represent the possible stereoisomers which fit the dipole moment data.
5. Denote each chiral carbon atom in the above formulae with R or S.

### Problem 4

Poly[(R)-3-hydroxyalkanoic acids], PHAs, are synthesized by a variety of bacteria and function as intracellular carbon and energy storage materials. These polymers are also biodegradable in environments, such as soil, anaerobic

sewage and sea water. The inherent biologically mediated environmental degradability, useful physical properties, slow hydrolytic degradation and other favorable properties make bacterial polyesters exciting materials for both disposable biodegradable plastics (*good for a clean environment*) and special medical products.

1. PHB, Poly(3-hydroxybutanoic acid), produced by bacteria contains only (R)-HB repeating units, while that synthesized by polymer chemists may contain only (R)-HB or only (S)-HB or both (R)-and (S)-HB in an alternating manner or both but in random distributions. Sketch chain structures of the atactic PHB, syndiotactic PHB and isotactic PHBs and denote each chiral carbon with (R) or (S). Five monomeric units are enough for each chain.

(Note: In “PHB”, P means “poly” or “polymer of”, HB represents the monomeric units contained in poly(3-hydroxybutanoic acid) molecules.)

2. Suggest two types of monomers that could be used for polymer chemists to synthesize a PHB, regardless of the stereochemistry of the products.

3. Poly[(R)-3-hydroxybutanoic acid] can be synthesized by feeding the bacteria (such as *Alcaligenes Eutrophus*) with sodium acetate in a nitrogen-free media. It is believed that the key steps for the conversion of acetate to PHB are the activation of acetate molecules by coenzyme A and the subsequent formation of the coenzyme A activated acetoacetate, which is then reduced by a reductase to form coenzyme A activated monomer 3-hydroxybutyrate. Polymerization of the monomer is achieved by a polymerase which would build the polymer molecules with unique stereospecificity. Sketch these steps with structural formulae. For coenzyme A the conventional abbreviation, -S-CoA (-CoA is as good), should be used in the sketch.

4. If sodium propanoate is used (*as the sole carbon source*) in the feeding media instead of sodium acetate, the principal product will be a copolymer of 3-hydroxybutanoic acid and 3-hydroxypentanoic acid with the following generalized structure:

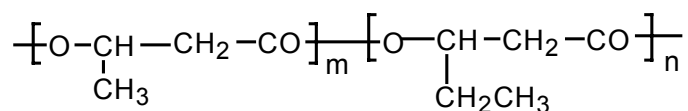



decomposition of proteins, forming  $[\text{Fe}_4\text{S}_3(\text{NO})_7]^-$ . The complex anion is bacteriostatic and antiseptic. X-ray crystallography shows that the complex anion has a structure as shown below:

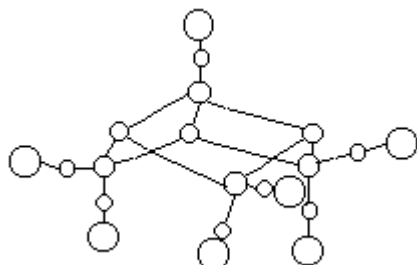

i) Blacken all the circles corresponding to iron atoms and add symbols Fe(A), Fe(B), Fe(C) and Fe(D) beside the circles in the sequence of top  $\rightarrow$  left  $\rightarrow$  right.

ii) The configuration of 3d electron shell of the iron atoms has been studied with modern

structural analysis. Knowing that the mean oxidation number of the four iron atoms is  $-0.5$ , give their configurations of 3d shell, respectively. Assume that each iron atom adopt  $sp^3$  hybridization.

5.  $[\text{Fe}_4\text{S}_3(\text{NO})_7]^-$  anion can be reduced and a new complex  $[\text{Fe}_2\text{S}_2(\text{NO})_4]^{2-}$  is formed which contains a cyclic structure unit of  $\text{Fe}_2\text{S}_2$ .

i) Write the structural formula for the anion  $[\text{Fe}_2\text{S}_2(\text{NO})_4]^{2-}$ .

ii) Give the oxidation state of each iron atom with Arabic numerals.

iii)  $[\text{Fe}_2\text{S}_2(\text{NO})_4]^{2-}$  can be converted into  $[\text{Fe}_2(\text{SCH}_3)_2(\text{NO})_4]^n$ , a carcinogen.

Which of the following three species is added to  $[\text{Fe}_2\text{S}_2(\text{NO})_4]^{2-}$ :  $\text{CH}_3^+$ ,  $\bullet\text{CH}_3$  or  $\text{CH}_3^-$ ? Assign the value of  $n$ .

## Problem 6

A surfactant molecule can generally be modeled as Fig. 1, where a circle represents the polar head (PH), i.e. the hydrophilic part of the molecule, and a rectangle represents the non-polar tail (NT), i. e. the hydrophobic part of the molecule.

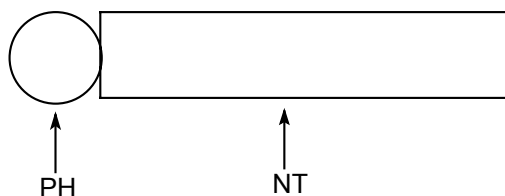

Fig. 11.

1. AOT is a surfactant. Its systematic name (IUPAC name) is sulfobutanedioic acid 1,4-bis-(2-ethylhexyl) ester sodium salt (formula  $\text{C}_{20}\text{H}_{37}\text{NaO}_7\text{S}$ ).

i) Write the structural formula for

AOT and fill its PH and NT in the circle and rectangle on your answer sheet.

ii) Choose the type of surfactant AOT among the following.

A. non-ionic; B. Anionic; C. cationic; D. others.

2. Mixing an aqueous solution of 50 mmol AOT with isooctane (volume ratio 1:1), a micellar extraction system will be formed in the isooctane phase (organic phase).

i) Using the model as shown in Fig. 1, draw a micelle with 10 AOT molecules under the given condition.

ii) What species are in the inner cavity of this micelle? Write their chemical formulas.

3. There is an aqueous solution containing the proteins as listed below:

protein	molecular weight ( $M_r$ )/ $10^4$	isoelectric point (PI)
A	1.45	11.1
B	1.37	7.8
C	6.45	4.9
D	6.80	4.9
E	2.40	4.7
F	2.38	0.5

The separation of proteins can be performed by mixing the AOT micellar extraction system with the solution. Adjusting the pH value of the solution to 4.5, only three of the above listed six proteins can be extracted into the micelles. Which proteins will be extracted?

4. The three proteins entered into the micelles will be separated from each other by the following procedure shown as in Fig. 2. Each extracted protein can be sequentially transported into a respective water phase.

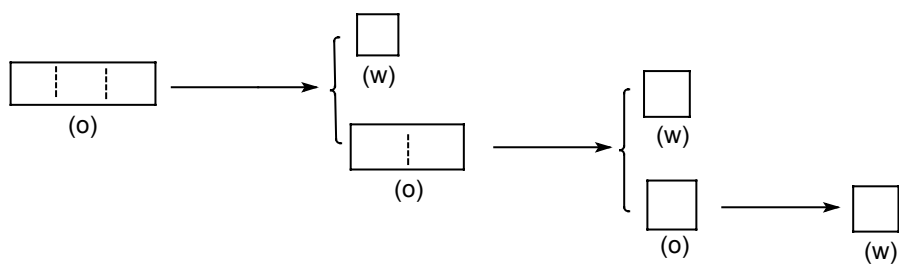
**Fig. 2**

*Note: (w) represents water phase; (o) represents organic phase.*

**Fill the three extracted proteins in the left boxes first and then separate them by the procedure given, and give the separation conditions above each arrow as well.**

## Solutions and Marking grid for the Theoretical Problems of the 27th IChO

### Problem 1 (total 17 points)

1.

i)

chemical equation

ii) (1. total 6 points)

$$\frac{\Delta_f G_m^\ominus(298\text{K})}{\text{kJ} \cdot \text{mol}^{-1}}$$

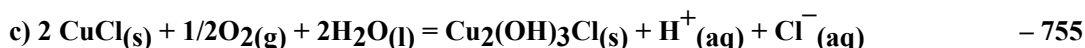
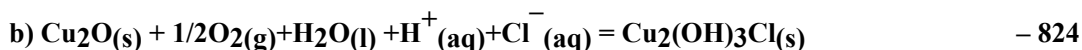
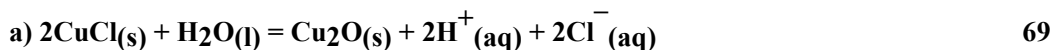

i) 2 points

ii) 2 points

iii) Calculation (dilute HCl solution can be considered as an ideal solution)

$$\begin{aligned} \Delta_r G_m(298\text{K}) &= \Delta_r G_m^\ominus(298\text{K}) + 2RT \ln [C_{\text{H}^+} / C_{\text{H}^+}^\ominus \cdot C_{\text{Cl}^-} / C_{\text{Cl}^-}^\ominus] \\ &= -22.3 \text{ kJ mol}^{-1} < 1 \end{aligned}$$

A. →

iii) 2 points

2. i) Formula :  $\ln \frac{k_c(T_2)}{k_c(T_1)} = \frac{E_a}{R} \left[ \frac{1}{T_1} - \frac{1}{T_2} \right]$  (2. total 4 points) i) 1 point

$$E_a = 34.2 \text{ kJ} \cdot \text{mol}^{-1} \quad \text{+ 1 point}$$

ii) overall reaction order = 0 ii) 1 point

when  $bp_{\text{O}_2} \gg 1$ ,  $r = k_c \theta = \frac{k_c b P_{\text{O}_2}}{1 + b P_{\text{O}_2}}$ ;  $r = k_c$ , zero order + 1 point

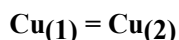
3. i) (C)  $E > 0$  (3. total 3 points)ii) Net cell reaction: i) 1 point

Thermodynamic reason for choosing 3 (C) is

$$\Delta_r G_m < 0, \Delta_r G_m = -nFE \quad \therefore E > 0 \quad \text{ii) 2 points}$$

4.  $r = 1.30 \times 10^{-10} \text{ m}$  (4. total 4 points)

formula:  $a = 2\sqrt{2}r$  1 point

$$d = \frac{4(63.5 \times 0.75 + 65.4 \times 0.25) \times 10^{-3}}{a^3 N_A} \quad \text{1.5 points}$$

$$= 8.51 \times 10^{-3} \text{ kg} \cdot \text{m}^{-3}$$

$$r^3 = 2.209 \times 10^{-30} \text{ m}^3 \quad \text{1 point}$$

$$r = 1.30 \times 10^{-10} \text{ m} \quad \text{0.5 point}$$

total (17 points)

**Problem 2 (total 20 points)**

1. A 1 point

2. B 2 points

$$(1.4 \times 10^{-3} \times 0.01) \div [\text{Cl}^-] = 4.9 \times 10^{-4} \text{ mol dm}^{-3},$$

$$[\text{Cl}^-] = 2.9 \times 10^{-4} \text{ mol dm}^{-3} \quad 1 \text{ point}$$

$$\begin{aligned} \text{Excess } [\text{Cl}^-] &= 1.6 \times 10^{-2} - 2.9 \times 10^{-3} \\ &\cong 1.6 \times 10^{-2} \text{ mol dm}^{-3} \quad 1 \text{ point} \end{aligned}$$

To reduce the interference of  $\text{Cl}^-$ , at least  $1.6 \times 10^{-2} \text{ mol Ag}^+$  ion, or  $8.0 \times 10^{-3} \text{ Ag}_2\text{SO}_4$  has to be added to  $1 \text{ dm}^3$  sample solution.

1 point

(2. total 5 points)

$$3. DE = E_2 - E_1 = 0.059 \lg \{(C_X V_X + C_S V_S) / (C_X [V_X + V_S])\}$$

2 points

$$0.03 = 0.059 \lg [(25.00 V_X + 0.10) / (26.00 \times C_X)] \quad 1 \text{ point}$$

$$C_X = 1.7 \times 10^{-3} \text{ mol dm}^{-3} \quad 1 \text{ point}$$

$$\text{pNO}_3 = 2.77 \quad 1 \text{ point}$$

(3. total 5 points)

4. pH = 4.4 1 point

$$(1.4 \times 10^{-3} \times x) \div 1.6 \times 10^{-2} = 2.7 \times 10^{-3} \quad 2 \text{ points}$$

$$x = 3.1\% > 1\% \quad 1 \text{ point}$$

$$(1.4 \times 10^{-3} \times 0.01) \div [\text{CH}_3\text{COO}^-] = 2.7 \times 10^{-3} \quad 1 \text{ point}$$

$$[\text{CH}_3\text{COO}^-] = 5.2 \times 10^{-3} \text{ mol dm}^{-3} \quad 1 \text{ point}$$

$$1.6 \times 10^{-2} - 5.2 \times 10^{-3} = 1.08 \times 10^{-2} \text{ mol dm}^{-3} \quad 1 \text{ point}$$

$$\{[\text{H}^+] \times 5.2 \times 10^{-3}\} \div (1.08 \times 10^{-2}) = 2.2 \times 10^{-5} \quad 1 \text{ point}$$

$$[\text{H}^+] = 4.3 \times 10^{-5} \text{ mol dm}^{-3} \quad 1 \text{ point}$$

$$\text{pH} = 4.4 \quad (4. \text{ total 9 points})$$

**Problem 3 (total 15 points)**

1.

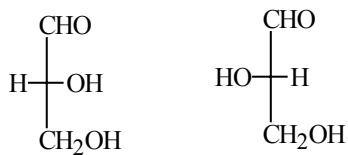
D(+)  
1 pointL(-)  
1 point

2.

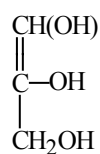

2 points

3.

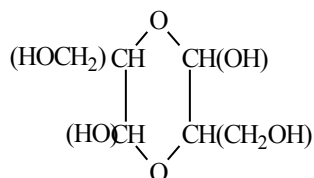

3 points

4.

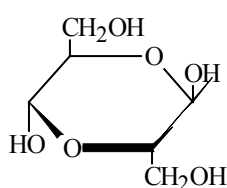

2 points

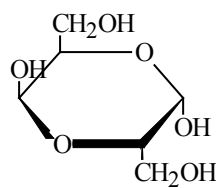

2 points

5.

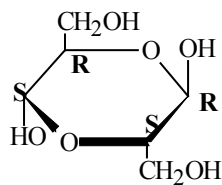

2 points

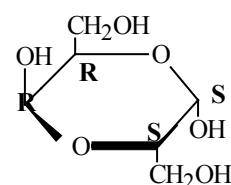

2 points

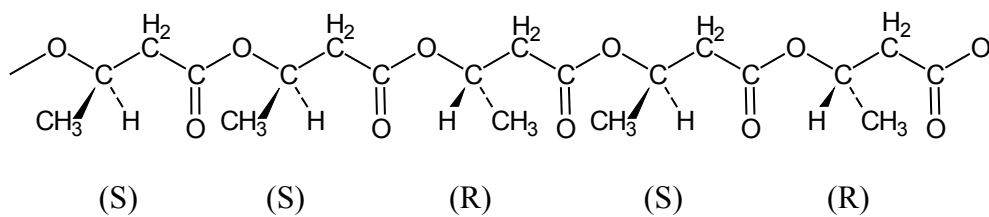
**Problem 4 ( total 16 points)****1. Atactic PHB:**

1 point

other arrangements with (R) and (S) randomly distributed along the chain are correct, e.g.,

RSRRS, SRSSR, RRSRS, etc.

**Syndiotactic PHB:** This polymer has (R) and (S) units positioned along the chain in an alternating manner: RSRSR (or SRSRS). **1 point**

**Isotactic PHB:** All the chiral centers have the same configuration. There are 2 types of the isotactic PHBs: SSSSS and RRRRR **2 points**

(ref. Preparatory Problem 52)

## 2. Monomer 1

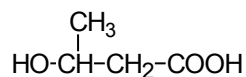

3-hydroxybutanoic acid

**2 points**

## Monomer 2

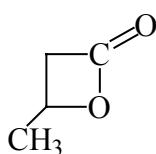

( Ref. Preparatory Problem 52 )

**2 points**

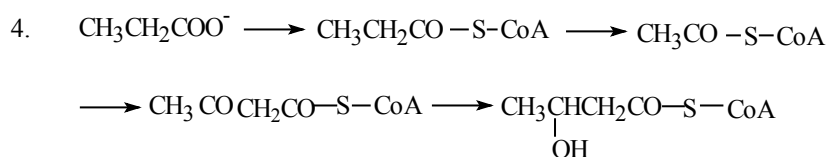
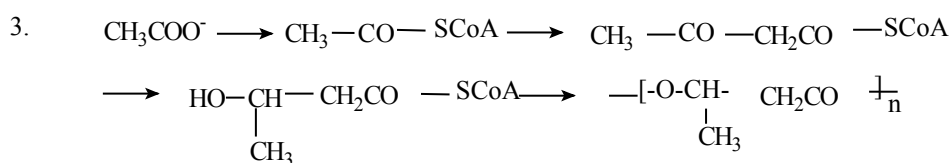

(coenzyme A activated monomer 3-hydroxypentanoic acid)

This monomer may also be written in the following way:

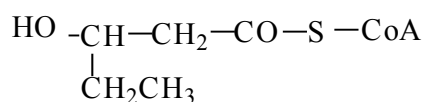

Polymerization together of these two monomers will result in the desired copolymer:

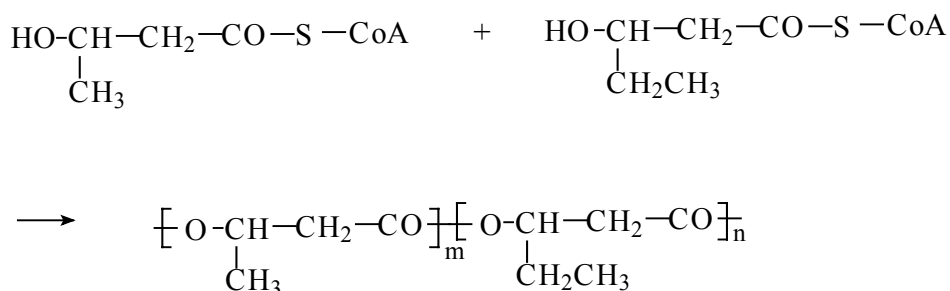

( Ref. Preparatory Problem 52 and 55) 4 points for Question 3  
4 points for Question 4

### Problem 5 (total 18 points)

1. The HOMO of NO molecule is  $\pi^*$ , its electron arrangement is  $\uparrow$ ;  
the LUMO of NO molecule is  $\pi^*$ . 1+1+1= 3 points

2. B. 1 point

3. B. 2 points

4.

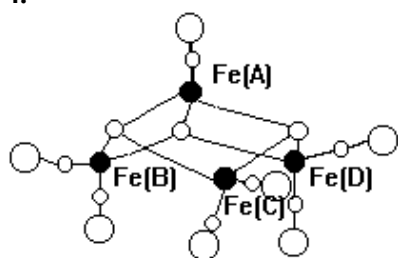

Fe(A) having  $3d^7$  configuration; Fe(B), Fe(C),  
Fe(D) having  $3d^9$  configuration.  
 $0.5 \times 4 + 0.5 \times 4 + 2 = 6$  points

5. i) 2 points

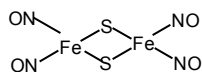

ii) Fe (-1) Fe (-1) 1+1 = 2 points

iii) The species added to S atom is  $\underline{\text{CH}_3^+}$ ; n= 0 .

1+1= 2 points

### Problem 6 (total 13 points)

1. i) AOT molecule model: 1 point for PH; 1 point for NT.

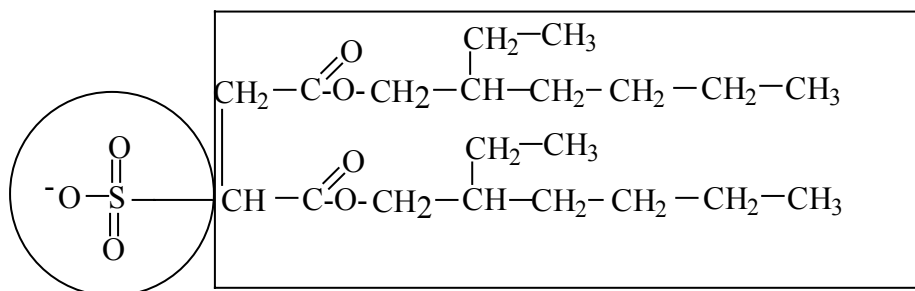

ii) B. 1 point (3 points for question 1)

2. i)

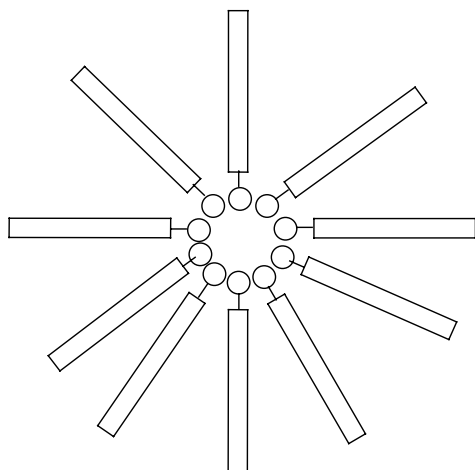

1 point for direction of the molecules

ii)  $\text{H}_2\text{O}$ ,  $\text{Na}^+$

1 point for species in the cavity

(2 Points for question 2)

3. A. B. E. (3 Points For question 3)

4. Fill the letters represented the extracted proteins in the frames and the separation conditions above the arrows respectively: (6 points for question 4)

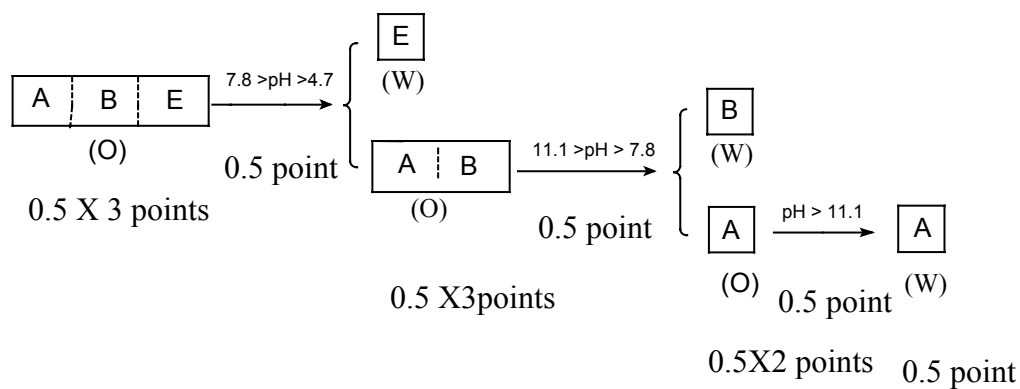

## The Conceptual Links between the Preparatory Problems and the Theoretical Problems

Theoretical Problem	Preparatory Problem
1	2, 5, 38-47
2	21-32
3	11-20
4	33-36, 52, 54-55
5	3-4, 8-9, 56-57
6	10, 48

## Marking Grid for the Theoretical Problems

Problem	Blue points	Red points	
1		17	10
2		20	10
3		15	10
4		16	10
5		18	10
6		13	10
		total	60



4.  $r =$  \_\_\_\_\_

formula:

## Problem 2

1. Choose the answer by cycling the letter:

(A) Yes                      (B) No

2. Choose the answer by cycling the letter:

(A)  $\text{AgNO}_3$                       (B)  $\text{Ag}_2\text{SO}_4$                       (C)  $\text{AgClO}_4$

The amount of the selected substance which should be added into  $1 \text{ dm}^3$  of the sample solution

is \_\_\_\_\_ mol.

3. The  $\text{pNO}_3$  value of the milk serum is \_\_\_\_\_ .

Calculation procedures:

4. The pH value has to be lower than \_\_\_\_\_ .

Calculation procedures:

## Problem 3

1. Fischer projection formula and its configuration

**2. Reaction mechanism****3. Structural formula of the cyclic dimer****4. Haworth projection formula of the possible stereoisomers which meet the dipole moment data.****5. Mark all chiral carbon atoms using the R, S system.****Problem 4****1. Draw the chain structures for:****Atactic PHB****Syndiotactic PHB**

**Isotactic PHB**

2. Suggest two types of monomers for the synthesis of PHBs by structural formulae.

Monomer 1 and 2:

3. Sketch the 4 key steps for the conversion of acetate to PHB with structural formulae. The conventional abbreviation for co-enzyme A, -S-CoA (or -CoA) should be used in the sketch.



4. Rationalize the formation of the copolymer of 3-hydroxybutanoic acid and 3-hydroxypentanoic acid when sodium propanoate is used as the sole carbon source.

**Problem 5**

1. The HOMO of NO molecule is \_\_\_\_\_, its electron arrangement is \_\_\_\_\_ ; the LUMO of NO molecule is \_\_\_\_\_.

2. Choose the correct answer by circling the proper letter.

A. B. C.

3. Choose the correct answer by circling the proper letter.

A. B. C. D.

4.

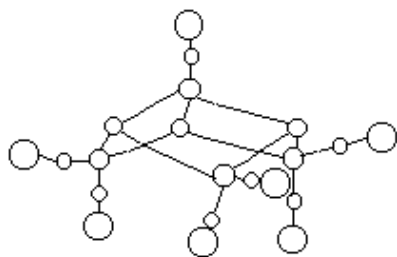

Iron atom(s) \_\_\_\_\_ has 3d<sub>□</sub> configuration;

Iron atom(s) \_\_\_\_\_ has 3d<sub>□</sub> configuration.

5. i) and ii)

iii) The species added to S atom is \_\_\_\_\_ ; n= \_\_\_\_\_ .

## Problem 6

1. i) AOT molecule model:



ii) Cycling the letter of the best choice:

A.      B.      C.      D.

2. I) Draw a 10 molecule model for the given micelle:

ii) The chemical formula(s) of the substance(s) in the micelle inner cavity \_\_\_\_\_.

3. Cycling the letters represented the three extracted proteins entered in the micelles:

A.    B.    C.    D.    E.    F.

4. Fill the letters represented the extracted proteins in the frames and the separation conditions above the arrows, respectively:

